

INTERNATIONAL SERIES IN PURE AND APPLIED MATHEMATICS

• • •

ELEMENTS OF PARTIAL
DIFFERENTIAL EQUATIONS

CONTENTS

<i>Preface</i>	v
CHAPTER 1. ORDINARY DIFFERENTIAL EQUATIONS IN MORE THAN TWO VARIABLES	1
1. Surfaces and Curves in Three Dimensions	1
2. Simultaneous Differential Equations of the First Order and the First Degree in Three Variables	7
3. Methods of Solution of $dx/P = dy/Q = dz/R$	10
4. Orthogonal Trajectories of a System of Curves on a Surface	15
5. Pfaffian Differential Forms and Equations	18
6. Solution of Pfaffian Differential Equations in Three Variables. . . .	26
7. Carathéodory's Theorem.	33
8. Application to Thermodynamics	39
Miscellaneous Problems	42
CHAPTER 2. PARTIAL DIFFERENTIAL EQUATIONS OF THE FIRST ORDER .	44
1. Partial Differential Equations.	44
2. Origins of First-order Partial Differential Equations	45
3. Cauchy's Problem for First-order Equations	47
4. Linear Equations of the First Order	49
5. Integral Surfaces Passing through a Given Curve	56
6. Surfaces Orthogonal to a Given System of Surfaces	57
7. Nonlinear Partial Differential Equations of the First Order	59
8. Cauchy's Method of Characteristics	61
9. Compatible Systems of First-order Equations	67
10. Charpit's Method	69
11. Special Types of First-order Equations.	70
12. Solutions Satisfying Given Conditions	73
13. Jacobi's Method	78
14. Applications of First-order Equations	81
Miscellaneous Problems	85
CHAPTER 3. PARTIAL DIFFERENTIAL EQUATIONS OF THE SECOND ORDER	88
1. The Origin of Second-order Equations	88
2. Second-order Equations in Physics	90
3. Higher-order Equations in Physics	94

4. Linear Partial Differential Equations with Constant Coefficients	96
5. Equations with Variable Coefficients	105
6. Characteristic Curves of Second-order Equations	110
7. Characteristics of Equations in Three Variables	115
8. The Solution of Linear Hyperbolic Equations	119
9. Separation of Variables	123
10. The Method of Integral Transforms	126
11. Nonlinear Equations of the Second Order	131
Miscellaneous Problems	136
 CHAPTER 4. LAPLACE'S EQUATION	 141
1. The Occurrence of Laplace's Equation in Physics	141
2. Elementary Solutions of Laplace's Equation	145
3. Families of Equipotential Surfaces	148
4. Boundary Value Problems	151
5. Separation of Variables	156
6. Problems with Axial Symmetry	161
7. Kelvin's Inversion Theorem	164
8. The Theory of Green's Function for Laplace's Equation	167
9. The Relation of Dirichlet's Problem to the Calculus of Variations	174
10. "Mixed" Boundary Value Problems	175
11. The Two-dimensional Laplace Equation	180
12. Relation of the Logarithmic Potential to the Theory of Functions	184
13. Green's Function for the Two-dimensional Equation	193
Miscellaneous Problems	197
 CHAPTER 5. THE WAVE EQUATION	 209
1. The Occurrence of the Wave Equation in Physics	209
2. Elementary Solutions of the One-dimensional Wave Equation	215
3. The Riemann-Volterra Solution of the One-dimensional Wave Equation	221
4. Vibrating Membranes: Application of the Calculus of Variations	226
5. Three-dimensional Problems	232
6. General Solutions of the Wave Equation	239
7. Green's Function for the Wave Equation	244
8. The Nonhomogeneous Wave Equation	249
9. Riesz's Integrals	254
10. The Propagation of Sound Waves of Finite Amplitude	257
Miscellaneous Problems	262
 CHAPTER 6. THE DIFFUSION EQUATION	 274
1. The Occurrence of the Diffusion Equation in Physics	274
2. The Resolution of Boundary Value Problems for the Diffusion Equation	278

3. Elementary Solutions of the Diffusion Equation.	282
4. Separation of Variables	286
5. The Use of Integral Transforms.	290
6. The Use of Green's Functions	294
7. The Diffusion Equation with Sources	299
Miscellaneous Problems	303
APPENDIX. SYSTEMS OF SURFACES	309
1. One-parameter Systems	309
2. Two-parameter Systems	311
3. The Edge of Regression	312
4. Ruled Surfaces	314
<i>Solutions to the Odd-numbered Problems</i>	<i>315</i>
<i>Index</i>	<i>323</i>

~~6~~

Chapter I

ORDINARY DIFFERENTIAL EQUATIONS IN MORE THAN TWO VARIABLES

In this chapter we shall discuss the properties of ordinary differential equations in more than two variables. Parts of the theory of these equations play important roles in the theory of partial differential equations, and it is essential that they should be understood thoroughly before the study of partial differential equations is begun. Collected in the first section are the basic concepts from solid geometry which are met with most frequently in the study of differential equations.

1. Surfaces and Curves in Three Dimensions

By considering special examples it is readily seen that if the rectangular Cartesian coordinates (x, y, z) of a point in three-dimensional space are connected by a single relation of the type

$$f(x, y, z) = 0 \quad (1)$$

the point lies on a surface. For that reason we call the relation (1) the equation of a surface S .

To demonstrate this generally we suppose a point (x, y, z) satisfying equation (1). Then any increments $(\delta x, \delta y, \delta z)$ in (x, y, z) are related by the equation

$$\frac{\partial f}{\partial x} \delta x + \frac{\partial f}{\partial y} \delta y + \frac{\partial f}{\partial z} \delta z = 0$$

so that two of them can be chosen arbitrarily. In other words, in the neighborhood of $P(x, y, z)$ there are points $P'(x + \xi, y + \eta, z + \zeta)$ satisfying (1) and for which any two of ξ, η, ζ are chosen arbitrarily and the third is given by

$$\xi \frac{\partial f}{\partial x} + \eta \frac{\partial f}{\partial y} + \zeta \frac{\partial f}{\partial z} = 0$$

The projection of the initial direction PP' on the plane xOy may therefore be chosen arbitrarily. In other words, equation (1) is, in general, a relation satisfied by points which lie on a surface.

If we have a set of relations of the form

$$x = F_1(u,v), \quad y = F_2(u,v), \quad z = F_3(u,v) \quad (2)$$

then to each pair of values of u, v there corresponds a set of numbers (x,y,z) and hence a point in space. Not every point in space corresponds to a pair of values of u and v , however. If we solve the first pair of equations

$$x = F_1(u,v), \quad y = F_2(u,v)$$

we may express u and v as functions of x and y , say

$$u = \lambda(x,y), \quad v = \mu(x,y)$$

so that u and v are determined once x and y are known. The corresponding value of z is obtained by substituting these values for u and v into the third of the equations (2). In other words, the value of z is determined once those of x and y are known. Symbolically

$$z = F_3\{\lambda(x,y), \mu(x,y)\}$$

so that there is a functional relation of the type (1) between the three coordinates x, y , and z . Now equation (1) expresses the fact that the point (x,y,z) lies on a surface. The equations (2) therefore express the fact that any point (x,y,z) determined from them always lies on a fixed surface. For that reason equations of this type are called *parametric equations* of the surface.

It should be observed that parametric equations of a surface are *not* unique; i.e., the same surface (1) can be reached from different forms of the functions F_1, F_2, F_3 of the set (2). As an illustration of this fact we see that the set of parametric equations

$$x = a \sin u \cos v, \quad y = a \sin u \sin v, \quad z = a \cos u$$

and the set

$$x = a \frac{1 - v^2}{1 + v^2} \cos u, \quad y = a \frac{1 - v^2}{1 + v^2} \sin u, \quad z = \frac{2av}{1 + v^2}$$

both yield the spherical surface

$$x^2 + y^2 + z^2 = a^2$$

A surface may be envisaged as being generated by a curve. A point whose coordinates satisfy equation (1) and which lies in the plane $z = k$ has its coordinates satisfying the equations

$$z = k, \quad f(x,y,k) = 0 \quad (3)$$

which expresses the fact that the point (x,y,z) lies on a curve, Γ_k , say, in the plane $z = k$ (cf. Fig. 1). For example, if S is the sphere with equation $x^2 + y^2 + z^2 = a^2$, then points of S with $z = k$ have

$$z = k, \quad x^2 + y^2 = a^2 - k^2$$

showing that, in this instance, Γ_k is a circle of radius $(a^2 - k^2)^{\frac{1}{2}}$ which is real if $k < a$. As k varies from $-a$ to $+a$, each point of the sphere is covered by one such circle. We may therefore think of the surface of the sphere as being "generated" by such circles. In the general case we can similarly think of the surface (1) as being generated by the curves (3).

We can look at this in another way. The curve symbolized by the pair of equations (3) can be thought of as the intersection of the surface (1) with the plane $z = k$. This idea can readily be generalized. If a point whose coordinates are (x, y, z) lies on a surface S_1 , then there must be a relation of the form $f(x, y, z) = 0$ between these coordinates. If, in addition, the point (x, y, z) lies on a surface S_2 , its coordinates will satisfy a relation of the same type, say $g(x, y, z) = 0$. Points common

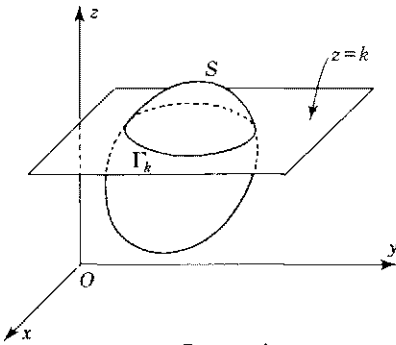

Figure 1

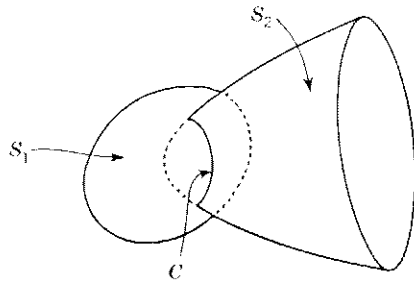

Figure 2

to S_1 and S_2 will therefore satisfy a pair of equations

$$f(x, y, z) = 0, \quad g(x, y, z) = 0 \quad (4)$$

Now the two surfaces S_1 and S_2 will, in general, intersect in a curve C , so that, in general, the locus of a point whose coordinates satisfy a pair of relations of the type (4) is a curve in space (cf. Fig. 2).

A curve may be specified by parametric equations just as a surface may. Any three equations of the form

$$x = f_1(t), \quad y = f_2(t), \quad z = f_3(t) \quad (5)$$

in which t is a continuous variable, may be regarded as the parametric equations of a curve. For if P is any point whose coordinates are determined by the equations (5), we see that P lies on a curve whose equations are

$$\Phi_1(x, y) = 0, \quad \Phi_2(x, z) = 0$$

where $\Phi_1(x, y) = 0$ is the equation obtained by eliminating t from the equations $x = f_1(t)$, $y = f_2(t)$ and where $\Phi_2(x, z) = 0$ is the one obtained

by eliminating t between the pair $x = f_1(t)$, $z = f_3(t)$. A usual parameter t to take is the length of the curve measured from some fixed point. In this case we replace t by the symbol s .

If we assume that P is any point on the curve

$$x = x(s), \quad y = y(s), \quad z = z(s) \quad (6)$$

which is characterized by the value s of the arc length, then s is the distance P_0P of P from some fixed point P_0 measured along the curve

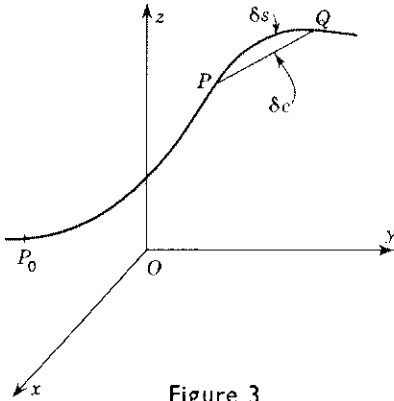

Figure 3

Similarly if Q is a point at a distance δs along the curve from P , the distance P_0Q will be $s + \delta s$, and the coordinates of Q will be, as a consequence,

$$\{x(s + \delta s), y(s + \delta s), z(s + \delta s)\}$$

The distance δs is the distance from P to Q measured along the curve and is therefore greater than δc , the length of the chord PQ . However, in many cases, as Q approaches the point P , the difference $\delta s - \delta c$ becomes relatively less. We shall

therefore confine our attention to curves for which

$$\lim_{\delta s \rightarrow 0} \frac{\delta c}{\delta s} = 1 \quad (7)$$

On the other hand, the direction cosines of the chord PQ are

$$\left\{ \frac{x(s + \delta s) - x(s)}{\delta c}, \frac{y(s + \delta s) - y(s)}{\delta c}, \frac{z(s + \delta s) - z(s)}{\delta c} \right\}$$

and by Maclaurin's theorem

$$x(s + \delta s) - x(s) = \delta s \left(\frac{dx}{ds} \right) + O(\delta s^2)$$

so that the direction cosines reduce to

$$\left\{ \frac{\delta s}{\delta c} \left[\frac{dx}{ds} + O(\delta s) \right], \frac{\delta s}{\delta c} \left[\frac{dy}{ds} + O(\delta s) \right], \frac{\delta s}{\delta c} \left[\frac{dz}{ds} + O(\delta s) \right] \right\}$$

As δs tends to zero, the point Q tends towards the point P , and the chord PQ takes up the direction to the tangent to the curve at P . If we let $\delta s \rightarrow 0$ in the above expressions and make use of the limit (7), we see that the direction cosines of the tangent to the curve (6) at the point P are

$$\left(\frac{dx}{ds}, \frac{dy}{ds}, \frac{dz}{ds} \right) \quad (8)$$

In the derivation of this result it has been assumed that the curve (6) is completely arbitrary. Now we shall assume that the curve C given by the equations (6) lies on the surface S whose equation is $F(x,y,z) = 0$ (cf. Fig. 4). The typical point $\{x(s),y(s),z(s)\}$ of the curve lies on this surface if

$$F[x(s),y(s),z(s)] = 0 \quad (9)$$

and if the curve lies entirely on the surface, equation (9) will be an identity for all values of s . Differentiating equation (9) with respect to s , we obtain the relation

$$\frac{\partial F}{\partial x} \frac{dx}{ds} + \frac{\partial F}{\partial y} \frac{dy}{ds} + \frac{\partial F}{\partial z} \frac{dz}{ds} = 0 \quad (10)$$

Now by the formulas (8) and (10) we see that the tangent T to the curve C at the point P is perpendicular to the line whose direction ratios are

$$\left(\frac{\partial F}{\partial x}, \frac{\partial F}{\partial y}, \frac{\partial F}{\partial z} \right) \quad (11)$$

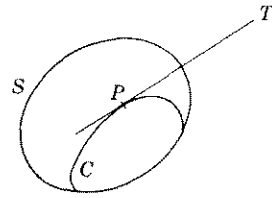

Figure 4

The curve C is arbitrary except that it passes through the point P and lies on the surface S . It follows that the line with direction ratios (11) is perpendicular to the tangent to every curve lying on S and passing through P . Hence the direction (11) is the direction of the *normal* to the surface S at the point P .

If the equation of the surface S is of the form

$$z = f(x,y)$$

and if we write

$$\frac{\partial z}{\partial x} = p, \quad \frac{\partial z}{\partial y} = q \quad (12)$$

then since $F = f(x,y) - z$, it follows that $F_x = p$, $F_y = q$, $F_z = -1$ and the direction cosines of the normal to the surface at the point (x,y,z) are

$$\left(\frac{p, q, -1}{\sqrt{p^2 + q^2 + 1}} \right) \quad (13)$$

The expressions (8) give the direction cosines of the tangent to a curve whose equations are of the form (6). Similar expressions may be derived for the case of a curve whose equations are given in the form (4).

The equation of the tangent plane π_1 at the point $P(x,y,z)$ to the surface S_1 (cf. Fig. 5) whose equation is $F(x,y,z) = 0$ is

$$(X - x) \frac{\partial F}{\partial x} + (Y - y) \frac{\partial F}{\partial y} + (Z - z) \frac{\partial F}{\partial z} = 0 \quad (14)$$

where (X, Y, Z) are the coordinates of any other point of the tangent

plane. Similarly the equation of the tangent plane π_2 at P to the surface S_2 whose equation is $G(x,y,z) = 0$ is

$$(X - x) \frac{\partial G}{\partial x} + (Y - y) \frac{\partial G}{\partial y} + (Z - z) \frac{\partial G}{\partial z} = 0 \quad (15)$$

The intersection L of the planes π_1 and π_2 is the tangent at P to the curve

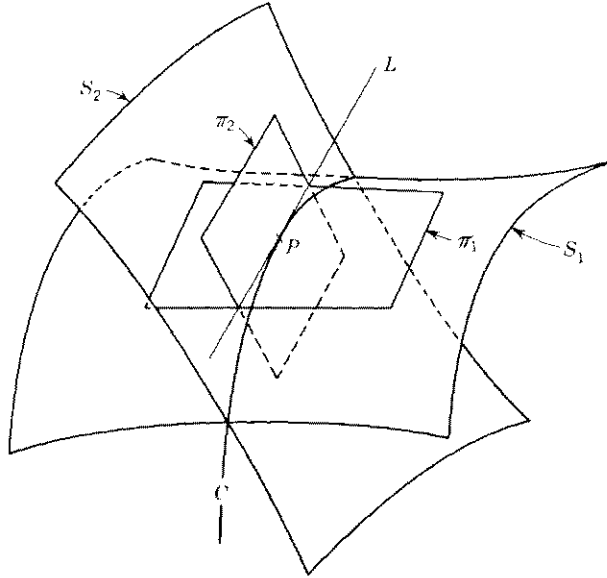

Figure 5

C which is the intersection of the surfaces S_1 and S_2 . It follows from equations (14) and (15) that the equations of the line L are

$$\frac{X - x}{\frac{\partial F}{\partial y} \frac{\partial G}{\partial z} - \frac{\partial F}{\partial z} \frac{\partial G}{\partial y}} = \frac{Y - y}{\frac{\partial F}{\partial z} \frac{\partial G}{\partial x} - \frac{\partial F}{\partial x} \frac{\partial G}{\partial z}} = \frac{Z - z}{\frac{\partial F}{\partial x} \frac{\partial G}{\partial y} - \frac{\partial F}{\partial y} \frac{\partial G}{\partial x}} \quad (16)$$

In other words, the direction ratios of the line L are

$$\left(\frac{\partial(F,G)}{\partial(y,z)}, \frac{\partial(F,G)}{\partial(z,x)}, \frac{\partial(F,G)}{\partial(x,y)} \right) \quad (16)$$

Example 1. The direction cosines of the tangent at the point (x,y,z) to the conic $ax^2 + by^2 + cz^2 = 1$, $x + y + z = 1$ are proportional to $(by - cz, cz - ax, ax - by)$.

In this instance

$$F = ax^2 + by^2 + cz^2 - 1$$

and

$$G = x + y + z - 1$$

so that

$$\frac{\partial(F,G)}{\partial(y,z)} = \begin{vmatrix} 2by & 2cz \\ 1 & 1 \end{vmatrix} = 2(by - cz)$$

etc., and the result follows from the expressions (16).

PROBLEMS

1. Show that the condition that the surfaces $F(x, y, z) = 0$, $G(x, y, z) = 0$ should touch is that the eliminant of x , y , and z from these equations and the equations $F_x : G_x = F_y : G_y = F_z : G_z$ should hold.

Hence find the condition that the plane $lx + my + nz + p = 0$ should touch the central conicoid $ax^2 + by^2 + cz^2 = 1$.

2. Show that the condition that the curve $u(x, y, z) = 0$, $v(x, y, z) = 0$ should touch the surface $w(x, y, z) = 0$ is that the eliminant of x , y , and z from these equations and the further relation

$$\frac{\partial(u, v, w)}{\partial(x, y, z)} = 0$$

should be valid.

Using this criterion, determine the condition for the line

$$\frac{x - a}{l} = \frac{y - b}{m} = \frac{z - c}{n}$$

to touch the quadric $ax^2 + by^2 + cz^2 = 1$.

2. Simultaneous Differential Equations of the First Order and the First Degree in Three Variables

Systems of simultaneous differential equations of the first order and first degree of the type

$$\frac{dx_i}{dt} = f_i(x_1, x_2, \dots, x_n, t) \quad i = 1, 2, \dots, n \quad (1)$$

arise frequently in mathematical physics. The problem is to find n functions x_i , which depend on t and the initial conditions (i.e., the values of x_1, x_2, \dots, x_n when $t = 0$) and which satisfy the set of equations (1) identically in t .

For example, a differential equation of the n th order

$$\frac{d^n x}{dt^n} = f\left(t, x, \frac{dx}{dt}, \frac{d^2 x}{dt^2}, \dots, \frac{d^{n-1} x}{dt^{n-1}}\right) \quad (2)$$

may be written in the form

$$\begin{aligned} \frac{dx}{dt} &= y_1, & \frac{dy_1}{dt} &= y_2, & \frac{dy_2}{dt} &= y_3, \dots, \\ & & & & \frac{dy_{n-1}}{dt} &= f(t, x, y_1, y_2, \dots, y_{n-1}) \end{aligned}$$

showing that it is a special case of the system (1).

Equations of the kind (1) arise, for instance, in the general theory of radioactive transformations due to Rutherford and Soddy.¹

¹ E. Rutherford, J. Chadwick and C. D. Ellis, "Radiations from Radioactive Substances" (Cambridge, London, 1930), chap. I.

A third example of the occurrence of systems of differential equations of the kind (1) arises in analytical mechanics. In Hamiltonian form the equations of motion of a dynamical system of n degrees of freedom assume the forms

$$\frac{dp_i}{dt} = -\frac{\partial H}{\partial q_i}, \quad \frac{dq_i}{dt} = \frac{\partial H}{\partial p_i} \quad i = 1, 2, \dots, n \quad (3)$$

where $H(q_1, q_2, \dots, q_n, p_1, p_2, \dots, p_n, t)$ is the Hamiltonian function of the system. It is obvious that these Hamiltonian equations of motion form a set of the type (1) for the $2n$ unknown functions $q_1, q_2, \dots, q_n, p_1, p_2, \dots, p_n$, the solution of which provides a description of the properties of the dynamical system at any time t .

In particular, if the dynamical system possesses only one degree of freedom, i.e., if its configuration at any time is uniquely specified by a single coordinate q (such as a particle constrained to move on a wire), then the equations of motion reduce to the simple form

$$\frac{dp}{dt} = -\frac{\partial H}{\partial q}, \quad \frac{dq}{dt} = \frac{\partial H}{\partial p} \quad (4)$$

where $H(p, q, t)$ is the Hamiltonian of the system. If we write

$$-\frac{\partial H}{\partial q} = \frac{P(p, q, t)}{R(p, q, t)}, \quad \frac{\partial H}{\partial p} = \frac{Q(p, q, t)}{R(p, q, t)}$$

then we may put the equations (4) in the form

$$\frac{dp}{P(p, q, t)} = \frac{dq}{Q(p, q, t)} = \frac{dt}{R(p, q, t)} \quad (5)$$

For instance, for the simple harmonic oscillator of mass m and stiffness constant k the Hamiltonian is

$$H = \frac{p^2}{2m} + \frac{kq^2}{2}$$

so that the equations of motion are

$$\frac{dp}{-kmq} = \frac{dq}{p} = \frac{dt}{m}$$

Similarly if a heavy string is hanging from two points of support and if we take the y axis vertically upward through the lowest point O of the string, the equation of equilibrium may be written in the form

$$\frac{dx}{H} = \frac{dy}{W} = \frac{ds}{T} \quad (6)$$

where H is the horizontal tension at the lowest point, T is the tension

in the string at the point $P(x, y)$, and W is the weight borne by the portion OP of the string.

By trivial changes of variable we can bring equations (5) and (6) into the form

$$\frac{dx}{P} = \frac{dy}{Q} = \frac{dz}{R} \quad (7)$$

where P , Q , and R are given functions of x , y , and z . For that reason we study equations of this type now. In addition to their importance in theoretical investigations in physics they play an important role in the theory of differential equations, as will emerge later.

From equations (8) of Sec. I it follows immediately that the solutions of equations (7) in some way trace out curves such that at the point (x, y, z) the direction cosines of the curves are proportional to (P, Q, R) .

The existence and uniqueness of solutions of equations of the type (7) is proved in:

Theorem 1. *If the functions $f_1(x, y, z)$ and $f_2(x, y, z)$ are continuous in the region defined by $|x - a| < k$, $|y - b| < l$, $|z - c| < m$, and if in that region the functions satisfy a Lipschitz condition of the type*

$$\begin{aligned} |f_1(x, y, z) - f_1(x, \eta, \zeta)| &\leq A_1|y - \eta| + B_1|z - \zeta| \\ |f_2(x, y, z) - f_2(x, \eta, \zeta)| &\leq A_2|y - \eta| + B_2|z - \zeta| \end{aligned}$$

then in a suitable interval $|x - a| < h$ there exists a unique pair of functions $y(x)$ and $z(x)$ continuous and having continuous derivatives in that interval, which satisfy the differential equations

$$\frac{dy}{dx} = f_1(x, y, z), \quad \frac{dz}{dx} = f_2(x, y, z)$$

identically and which have the property that $y(a) = b$, $z(a) = c$, where the numbers a , b , and c are arbitrary.

We shall not prove this theorem here but merely assume its validity. A proof of it in the special case in which the functions f_1 and f_2 are linear in y and z is given in M. Golomb and M. E. Shanks, "Elements of Ordinary Differential Equations" (McGraw-Hill, New York, 1950), Appendix B. For a proof of the theorem in the general case the reader is referred to textbooks on analysis.¹

The results of this theorem are shown graphically in Fig. 6. According to the theorem, there exists a cylinder $y = y(x)$, passing through the point $(a, b, 0)$, and a cylinder $z = z(x)$, passing through the point $(a, 0, c)$, such that $dy/dx = f_1$ and $dz/dx = f_2$. The complete solution of the pair of equations therefore consists of the set of points

¹ See, for instance, E. Goursat, "A Course in Mathematical Analysis" (Ginn, Boston, 1917), vol. II, pt. II, pp. 45ff.

common to the cylinders $y = y(x)$ and $z = z(x)$; i.e., it consists of their curve of intersection Γ .

This curve refers to a particular choice of initial conditions; i.e., it is the curve which not only satisfies the pair of differential equations but also passes through the point (a, b, c) . Now the numbers a , b , and c are arbitrary, so that the general solution of the given pair of equations will consist of the curves formed by the intersection of a one-parameter system of cylinders of which $y = y(x)$ is a particular member with another one-parameter system of cylinders containing $z = z(x)$ as a

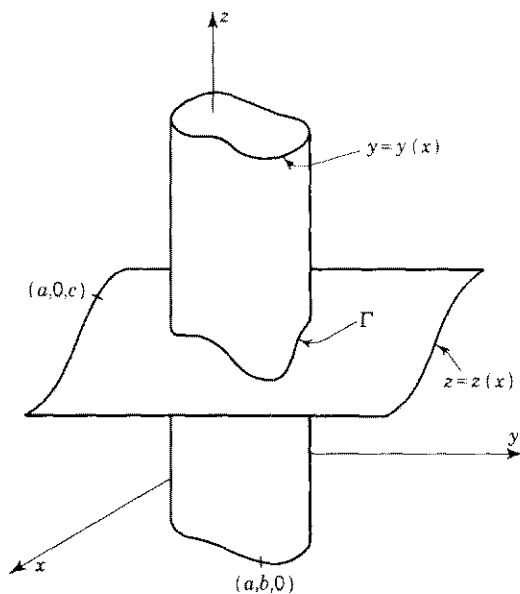

Figure 6

member. In other words, the general solution of a set of equations of the type (7) will be a two-parameter family of curves.

3. Methods of Solution of $dx/P = dy/Q = dz/R$

We pointed out in the last section that the integral curves of the set of differential equations

$$\frac{dx}{P} = \frac{dy}{Q} = \frac{dz}{R} \quad (1)$$

form a two-parameter family of curves in three-dimensional space. If we can derive from the equations (1) two relations of the form

$$u_1(x, y, z) = c_1; \quad u_2(x, y, z) = c_2 \quad (2)$$

involving two arbitrary constants c_1 and c_2 , then by varying these

constants we obtain a two-parameter family of curves satisfying the differential equations (1).

Method (a). In practice, to find the functions u_1 and u_2 we observe that any tangential direction through a point (x, y, z) to the surface $u_1(x, y, z) = c_1$ satisfies the relation

$$\frac{\partial u_1}{\partial x} dx + \frac{\partial u_1}{\partial y} dy + \frac{\partial u_1}{\partial z} dz = 0$$

If $u_1 = c_1$ is a suitable one-parameter system of surfaces, the tangential direction to the integral curve through the point (x, y, z) is also a tangential direction to this surface. Hence

$$P \frac{\partial u_1}{\partial x} + Q \frac{\partial u_1}{\partial y} + R \frac{\partial u_1}{\partial z} = 0$$

To find u_1 (and, similarly, u_2) we try to spot functions P' , Q' , and R' such that

$$PP' + QQ' + RR' = 0 \quad (3)$$

and such that there exists a function u_1 with the properties

$$P' = \frac{\partial u_1}{\partial x}, \quad Q' = \frac{\partial u_1}{\partial y}, \quad R' = \frac{\partial u_1}{\partial z} \quad (4)$$

i.e., such that

$$P' dx + Q' dy + R' dz \quad (5)$$

is an exact differential du_1 .

We shall illustrate this method by an example:

Example 2. Find the integral curves of the equations

$$\frac{dx}{y(x+y) - az} - \frac{dy}{x(x+y) - az} = \frac{dz}{z(x+y)} \quad (6)$$

In this case we have, in the above notation,

$$P = y(x+y) - az, \quad Q = x(x+y) - az, \quad R = z(x+y)$$

If we take

$$P' = \frac{1}{z}, \quad Q' = -\frac{1}{z}, \quad R' = -\frac{x+y}{z^2}$$

then condition (3) is satisfied, and the function u_1 of equation (4) assumes the form

$$u_1 = \frac{x-y}{z}$$

Similarly if we take

$$P' = x, \quad Q' = -y, \quad R' = -a$$

condition (3) is again satisfied, and the corresponding function is

$$u_2 = \frac{1}{2}(x^2 - y^2) - az$$

Hence the integral curves of the given differential equations are the members of the two-parameter family

$$x+y = c_1 z, \quad x^2 - y^2 - 2az = c_2 \quad (7)$$

We have derived the solution in this manner to illustrate the general argument given above. Written down in this way, the derivation of the solution of these equations seems to require a good deal of intuition in determining the forms of the functions P , Q , and R . In any actual example it is much simpler to try to cast the given differential equations into a form which suggests their solution. For example, if we add the numerators and denominators of the first two "fractions," their value is unaltered. We therefore have

$$\frac{dx + dy}{(x + y)^2} = \frac{dz}{z(x + y)}$$

which may be written in the form

$$\frac{d(x + y)}{x + y} = \frac{dz}{z}$$

This is an ordinary differential equation in the variables $x + y$ and z with general solution

$$x + y = c_1 z \quad (8)$$

where c_1 is a constant.

Similarly

$$\frac{x dx - y dy}{a(x - y)z} = \frac{dz}{z(x - y)}$$

which is equivalent to

$$x dx - y dy - a dz = 0$$

i.e., to

$$d(\frac{1}{2}x^2 - \frac{1}{2}y^2 - az) = 0$$

and hence leads to the solution

$$x^2 - y^2 - 2az = c_2 \quad (9)$$

Equations (8) and (9) together furnish the solution (7).

In some instances it is a comparatively simple matter to derive one of the sets of surfaces of the solution (2) but not so easy to derive the second set. When that occurs, it is possible to use the first solution in the following way: Suppose, for example, that we are trying to determine the integral curves of the set of differential equations (6) and that we have derived the set of surfaces (8) but cannot find the second set necessary for the complete solution. If we write

$$z = \frac{x + y}{c_1}$$

in the first of equations (6), we see that that equation is equivalent to the ordinary differential equation

$$\frac{dx}{y + a/c_1} = \frac{dy}{x - a/c_1}$$

which has solution

$$\left(x - \frac{a}{c_1}\right)^2 - \left(y + \frac{a}{c_1}\right)^2 = c_2$$

where c_2 is a constant. This solution may be written

$$x^2 - y^2 - \frac{2a}{c_1}(x + y) = c_2 \quad (10)$$

and we see immediately that, by virtue of equation (8), the curves of intersection of the surfaces (8) and (10) are identical with those of the surfaces (8) and (9).

Method (b). Suppose that we can find three functions P' , Q' , R' such that

$$\frac{P' dx + Q' dy + R' dz}{PP' + QQ' + RR'} \quad (11)$$

is an exact differential, dW' say, and that we can find three other functions P'' , Q'' , R'' such that

$$\frac{P'' dx + Q'' dy + R'' dz}{PP'' + QQ'' + RR''} \quad (12)$$

is also an exact differential, dW'' say. Then, since each of the ratios (11) and (12) is equal to dx/P , it follows that they are equal to each other. This in turn implies that

$$dW' = dW''$$

so that we have derived the relation

$$W' = W'' + c_1$$

between x , y , and z . As previously, c_1 denotes an arbitrary constant.

Example 3. Solve the equations

$$\frac{dx}{y + \alpha z} = \frac{dy}{z + \beta x} = \frac{dz}{x + \gamma y}$$

Each of these ratios is equal to

$$\frac{\lambda dx + \mu dy + \nu dz}{\lambda(y + \alpha z) + \mu(z + \beta x) + \nu(x + \gamma y)}$$

If λ , μ , and ν are constant multipliers, this expression will be an exact differential if it is of the form

$$\frac{1}{\rho} \frac{\lambda dx + \mu dy + \nu dz}{\lambda x + \mu y + \nu z}$$

and this is possible only if

$$\left. \begin{aligned} -\rho\lambda + \beta\mu - \nu &= 0 \\ \lambda - \rho\mu - \gamma\nu &= 0 \\ \alpha\lambda + \mu - \rho\nu &= 0 \end{aligned} \right\} \quad (13)$$

Regarded as equations in λ , μ , and ν , these equations possess a solution only if ρ is a root of the equation

$$\begin{vmatrix} -\rho & \beta & 1 \\ 1 & -\rho & \gamma \\ \alpha & 1 & -\rho \end{vmatrix} = 0 \quad (14)$$

which is equivalent to

$$\rho^3 + (\alpha + \beta + \gamma)\rho + 1 + \alpha\beta\gamma = 0 \quad (15)$$

This equation has three roots, which we may denote by ρ_1, ρ_2, ρ_3 . If we substitute the value ρ_1 for ρ in the equation (14) and solve to find $\lambda = \lambda_1, \mu = \mu_1, \nu = \nu_1$, then in the notation of (13)

$$dW^{\rho_1} = \frac{1}{\rho_1} \frac{\lambda_1 dx - \mu_1 dy + \nu_1 dz}{\lambda_1 x - \mu_1 y + \nu_1 z}$$

so that $W^{\rho_1} = \log(\lambda_1 x - \mu_1 y + \nu_1 z)^{1/\rho_1}$

Similarly $W^{\rho_2} = \log(\lambda_2 x - \mu_2 y + \nu_2 z)^{1/\rho_2}$

and (13) is equivalent to the relation

$$(\lambda_1 x - \mu_1 y + \nu_1 z)^{1/\rho_1} = c_1 (\lambda_2 x - \mu_2 y + \nu_2 z)^{1/\rho_2}$$

where c_1 is a constant. In a similar way we can show that

$$(\lambda_1 x - \mu_1 y + \nu_1 z)^{1/\rho_1} = c_2 (\lambda_3 x - \mu_3 y + \nu_3 z)^{1/\rho_3}$$

with c_2 a constant.

A more familiar form of the solution of these equations is that obtained by setting each of the ratios equal to dt . We then have relations of the type

$$\frac{1}{\rho_i} d \log(\lambda_i x - \mu_i y + \nu_i z) = dt$$

which give

$$\lambda_i x - \mu_i y + \nu_i z = c_i e^{\rho_i t}$$

where the c_i are constants and $i = 1, 2, 3$.

Method (c). When one of the variables is absent from one equation of the set (1), we can derive the integral curves in a simple way. Suppose, for the sake of definiteness, that the equation

$$\frac{dy}{Q} = \frac{dz}{R}$$

may be written in the form

$$\frac{dy}{dz} = f(y, z)$$

Then by the theory of ordinary differential equations this equation has a solution of the form

$$\phi(y, z, c_1) = 0$$

Solving this equation for z and substituting the value of z so obtained in the equation

$$\frac{dx}{P} = \frac{dy}{Q}$$

we obtain an ordinary differential equation of type

$$\frac{dx}{dx} = g(x, y, c_1)$$

whose solution

$$\psi(x, y, c_1, c_2) = 0$$

may readily be obtained.

Example 4. Find the integral curves of the equations

$$\frac{dx}{x+z} = \frac{dy}{y} = \frac{dz}{z-y^2} \quad (16)$$

The second of these equations may be written as

$$\frac{dz}{dy} = \frac{z}{y} + y$$

which is equivalent to

$$\frac{d}{dy} \left(\frac{z}{y} \right) = 1$$

and hence has solution

$$z = c_1 y + y^2 \quad (17)$$

From the first equation of the set (16) we have

$$\frac{dx}{dy} = \frac{x}{y} + \frac{z}{y}$$

and this, by equation (17), is equivalent to

$$\frac{dx}{dy} = \frac{x}{y} + c_1 + y$$

If we regard y as the independent variable and x as the dependent variable in this equation and then write it in the form

$$\frac{d}{dy} \frac{x}{y} = \frac{c_1}{y} + 1$$

we see that it has a solution of the form

$$x = c_1 y \log y + c_2 y + y^2 \quad (18)$$

The integral curves of the given differential equations (16) are therefore determined by the equations (17) and (18).

PROBLEMS

Find the integral curves of the sets of equations:

- $\frac{dx}{x(y+z)} = \frac{dy}{y(z-x)} = \frac{dz}{z(x+y)}$
- $\frac{a dx}{(b-c)yz} = \frac{b dy}{(c-a)zx} = \frac{c dz}{(a-b)xy}$
- $\frac{dx}{xz-y} = \frac{dy}{yz-x} = \frac{dz}{1-z^2}$
- $\frac{dx}{x^2(y^3-z^3)} = \frac{dy}{y^2(z^3-x^3)} = \frac{dz}{z^2(x^3-y^3)}$

4. Orthogonal Trajectories of a System of Curves on a Surface

The problem of finding the orthogonal trajectories of a system of plane curves is well known.¹ In three dimensions the corresponding problem is: Given a surface

$$F(x, y, z) = 0 \quad (1)$$

¹ M. Golomb and M. E. Shanks, "Elements of Ordinary Differential Equations" (McGraw-Hill, New York, 1950), pp. 29-31, 64-65.

and a system of curves on it, to find a system of curves each of which lies on the surface (1) and cuts every curve of the given system at right angles. The new system of curves is called the system of *orthogonal trajectories* on the surface of the given system of curves. The original system of curves may be thought of as the intersections of the surface (1) with the one-parameter family of surfaces

$$G(x,y,z) = c_1 \quad (2)$$

For example, a system of circles (shown by full lines in Fig. 7) is formed on the cone

$$x^2 + y^2 = z^2 \tan^2 \alpha \quad (3)$$

by the system of parallel planes

$$z = c_1 \quad (4)$$

where c_1 is a parameter. It is obvious on geometrical grounds that, in this case, the orthogonal trajectories are the generators shown dotted in Fig. 7. We shall prove this analytically at the end of this section (Example 5 below).

In the general case the tangential direction (dx, dy, dz) to the given curve through the point (x, y, z) on the surface (1) satisfies the equations

$$\frac{\partial F}{\partial x} dx + \frac{\partial F}{\partial y} dy + \frac{\partial F}{\partial z} dz = 0 \quad (5)$$

and

$$\frac{\partial G}{\partial x} dx + \frac{\partial G}{\partial y} dy + \frac{\partial G}{\partial z} dz = 0 \quad (6)$$

Hence the triads (dx, dy, dz) must be such that

$$\frac{dx}{P} = \frac{dy}{Q} = \frac{dz}{R} \quad (7)$$

where

$$P = \frac{\partial F}{\partial y} \frac{\partial G}{\partial z} - \frac{\partial F}{\partial z} \frac{\partial G}{\partial y}, \quad Q = \frac{\partial F}{\partial z} \frac{\partial G}{\partial x} - \frac{\partial F}{\partial x} \frac{\partial G}{\partial z}, \quad (8)$$

$$R = \frac{\partial F}{\partial x} \frac{\partial G}{\partial y} - \frac{\partial F}{\partial y} \frac{\partial G}{\partial x}$$

The curve through (x, y, z) of the orthogonal system has tangential

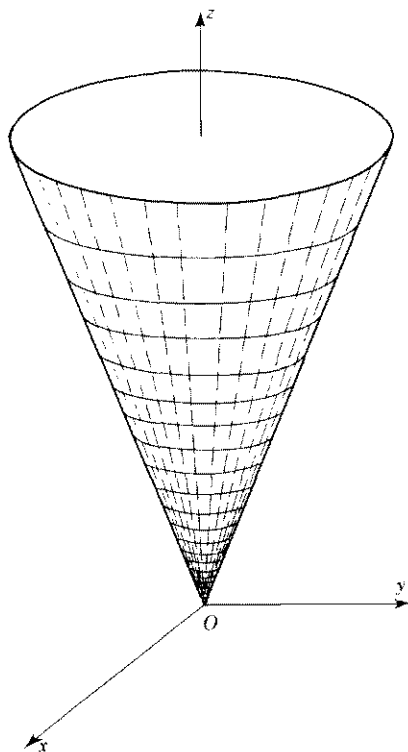

Figure 7

direction (dx', dy', dz') (cf. Fig. 8), which lies on the surface (1), so that

$$\frac{\partial F}{\partial x} dx' + \frac{\partial F}{\partial y} dy' + \frac{\partial F}{\partial z} dz' = 0 \tag{9}$$

and is perpendicular to the original system of curves. Therefore from equation (7) we have

$$P dx' + Q dy' + R dz' = 0 \tag{10}$$

Equations (9) and (10) yield the equations

$$\frac{dx'}{P'} = \frac{dy'}{Q'} = \frac{dz'}{R'} \tag{11}$$

where

$$\left. \begin{aligned} P' &= R \frac{\partial F}{\partial y} - Q \frac{\partial F}{\partial z}, \\ Q' &= P \frac{\partial F}{\partial z} - R \frac{\partial F}{\partial x}, \\ R' &= Q \frac{\partial F}{\partial x} - P \frac{\partial F}{\partial y} \end{aligned} \right\} \tag{12}$$

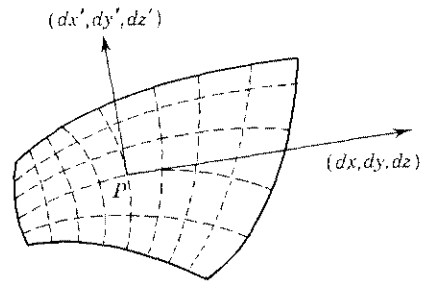

Figure 8

The solution of the equations (11) with the relation (1) gives the system of orthogonal trajectories.

To illustrate the method we shall consider the example referred to previously:

Example 5. Find the orthogonal trajectories on the cone $x^2 + y^2 = z^2 \tan^2 \alpha$ of its intersections with the family of planes parallel to $z = 0$.

The given system of circles on the cone is characterized by the pair of equations

$$x dx - y dy = \tan^2 \alpha z dz, \quad dz = 0$$

which are equivalent to

$$\frac{dx}{y} = \frac{dy}{-x} = \frac{dz}{0}$$

The system of orthogonal trajectories is therefore determined by the pair of equations

$$x dx + y dy = \tan^2 \alpha z dz, \quad y dx - x dy = 0$$

i.e., by

$$\frac{dx}{x} = \frac{dy}{y} = \frac{z \tan^2 \alpha dz}{x^2 + y^2}$$

which have solutions

$$x^2 + y^2 = z^2 \tan^2 \alpha, \quad x = c_1 y \tag{13}$$

where c_1 is a parameter. Hence the orthogonal trajectories are the generators of the cone formed by the intersection of its surface with the sheaf of planes $x = c_1 y$ passing through the z axis (cf. Fig. 7).

PROBLEMS

1. Find the orthogonal trajectories on the surface $x^2 + y^2 + 2fyz + d = 0$ of the curves of intersection with planes parallel to the plane xOy .
2. Find the orthogonal trajectories on the sphere $x^2 + y^2 + z^2 = a^2$ of its intersections with the paraboloids $x^2 = cz$, c being a parameter.
3. Find the equations of the system of curves on the cylinder $2y = x^2$ orthogonal to its intersections with the hyperboloids of the one-parameter system $xy = z - c$.
4. Show that the orthogonal trajectories on the hyperboloid

$$x^2 + y^2 - z^2 = 1$$

of the conics in which it is cut by the system of planes $x + y = c$ are its curves of intersection with the surfaces $(x - y)z = k$, where k is a parameter.

5. Find the orthogonal trajectories on the conicoid

$$(x + y)z = 1$$

of the conics in which it is cut by the system of planes

$$x - y + z = k$$

where k is a parameter.

5. Pfaffian Differential Forms and Equations

The expression

$$\sum_{i=1}^n F_i(x_1, x_2, \dots, x_n) dx_i \quad (1)$$

in which the F_i ($i = 1, 2, \dots, n$) are functions of some or all of the n independent variables x_1, x_2, \dots, x_n , is called a *Pfaffian differential form* in n variables. Similarly the relation

$$\sum_{i=1}^n F_i dx_i = 0 \quad (2)$$

is called a *Pfaffian differential equation*.

There is a fundamental difference between Pfaffian differential equations in two variables and those in a higher number of variables, and so we shall consider the two types separately.

In the case of two variables we may write equation (2) in the form

$$P(x, y) dx + Q(x, y) dy = 0 \quad (3)$$

which is equivalent to

$$\frac{dy}{dx} = f(x, y) \quad (4)$$

if we write $f(x, y) = -P/Q$. Now the functions $P(x, y)$ and $Q(x, y)$ are known functions of x and y , so that $f(x, y)$ is defined uniquely at each point of the xy plane at which the functions $P(x, y)$ and $Q(x, y)$ are defined. In particular, if these functions are single-valued, then

If the condition (9) is satisfied, we see that

$$\frac{\partial F}{\partial x} \frac{\partial v}{\partial y} = 0$$

The function v is a function of both x and y , so that $\partial v/\partial y$ is not identically zero. Hence

$$\frac{\partial F}{\partial x} = 0$$

which shows that the function F does not contain the variable x explicitly.

Another result we shall require later is:

Theorem 4. *If \mathbf{X} is a vector such that $\mathbf{X} \cdot \text{curl } \mathbf{X} = 0$ and μ is an arbitrary function of x, y, z then $(\mu\mathbf{X}) \cdot \text{curl } (\mu\mathbf{X}) = 0$.*

For, by the definition¹ of curl we have

$$\mu\mathbf{X} \cdot \text{curl } \mu\mathbf{X} = \sum_{x,y,z} (\mu P) \left\{ \frac{\partial(\mu R)}{\partial y} - \frac{\partial(\mu Q)}{\partial z} \right\}$$

where \mathbf{X} has components (P, Q, R) . The right-hand side of this equation may be written in the form

$$\mu^2 \sum_{x,y,z} P \left\{ \frac{\partial R}{\partial y} - \frac{\partial Q}{\partial z} \right\} - \mu \sum_{x,y,z} \left\{ PQ \frac{\partial \mu}{\partial z} - PR \frac{\partial \mu}{\partial y} \right\}$$

and the second of these sums is identically zero. Hence

$$\mu\mathbf{X} \cdot \text{curl } (\mu\mathbf{X}) = \{\mathbf{X} \cdot \text{curl } \mathbf{X}\} \cdot \mu^2$$

and the theorem follows at once.

The converse of this theorem is also true, as is seen by applying the factor $1/\mu$ to the vector $\mu\mathbf{X}$.

Having proved these preliminary results, we shall now return to the discussion of the Pfaffian differential equation (6). It is not true that all equations of this form possess integrals. If, however, the equation is such that there exists a function $\mu(x, y, z)$ with the property that $(P dx + Q dy + R dz)$ is an exact differential $d\phi$, the equation is said to be *integrable* and to possess an *integrating factor* $\mu(x, y, z)$. The function ϕ is called the *primitive* of the differential equation. The criterion for determining whether or not an equation of the type (6) is integrable is contained in:

Theorem 5. *A necessary and sufficient condition that the Pfaffian differential equation $\mathbf{X} \cdot d\mathbf{r} = 0$ should be integrable is that $\mathbf{X} \cdot \text{curl } \mathbf{X} = 0$.*

The condition is necessary, for if the equation

$$P dx + Q dy + R dz = 0 \quad (6)$$

¹ H. Lass, "Vector and Tensor Analysis" (McGraw-Hill, New York, 1950), p. 45.

is integrable, there exists between the variables x, y, z a function of the type

$$F(x, y, z) = C$$

where C is a constant. Writing z in terms of the differentials dx, dy we have

$$\frac{\partial F}{\partial x} dx + \frac{\partial F}{\partial y} dy + \frac{\partial F}{\partial z} dz = 0$$

we see that there must exist a function $\mu(x, y, z)$ such that

$$\mu P = \frac{\partial F}{\partial x}, \quad \mu Q = \frac{\partial F}{\partial y}, \quad \mu R = \frac{\partial F}{\partial z}$$

i.e., such that

$$\mu \mathbf{X} = \text{grad } F$$

so that since

$$\text{curl grad } F = 0$$

we have

$$\text{curl } (\mu \mathbf{X}) = 0$$

so that

$$\mu \mathbf{X} \cdot \text{curl } (\mu \mathbf{X}) = 0$$

From Theorem 4 it follows that

$$\mathbf{X} \cdot \text{curl } \mathbf{X} = 0$$

Again, the condition is sufficient. For, if z is treated as a constant, the differential equation (6) becomes

$$P(x, y, z) dx + Q(x, y, z) dy = 0$$

which by Theorem 2 possesses a solution of the form

$$U(x, y, z) = c_1$$

where the "constant" c_1 may involve z . Also there must exist a function μ such that

$$\frac{\partial U}{\partial x} = \mu P, \quad \frac{\partial U}{\partial y} = \mu Q \quad (10)$$

Substituting from the equations (10) into equation (6), we see that the latter equation may be written in the form

$$\frac{\partial U}{\partial x} dx + \frac{\partial U}{\partial y} dy + \frac{\partial U}{\partial z} dz + \left(\mu R - \frac{\partial U}{\partial z} \right) dz = 0$$

which is equivalent to the equation

$$dU - K dz = 0 \quad (11)$$

if we write

$$K = \mu R - \frac{\partial U}{\partial z} \quad (12)$$

Now we are given that $\mathbf{X} \cdot \text{curl } \mathbf{X} = 0$, and it follows from Theorem 4 that

$$\mu \mathbf{X} \cdot \text{curl } \mu \mathbf{X} = 0$$

Since

$$\begin{aligned} \mu \mathbf{X} = (\mu P, \mu Q, \mu R) &= \left(\frac{\partial U}{\partial x}, \frac{\partial U}{\partial y}, \frac{\partial U}{\partial z} + K \right) \\ &= \text{grad } U + (0, 0, K) \end{aligned}$$

hence

$$\begin{aligned} \mu \mathbf{X} \cdot \text{curl } (\mu \mathbf{X}) &= \left(\frac{\partial U}{\partial x}, \frac{\partial U}{\partial y}, \frac{\partial U}{\partial z} + K \right) \cdot \left(-\frac{\partial K}{\partial y}, \frac{\partial K}{\partial x}, 0 \right) \\ &= \frac{\partial U}{\partial x} \frac{\partial K}{\partial y} - \frac{\partial U}{\partial y} \frac{\partial K}{\partial x} \end{aligned}$$

Thus the condition $\mathbf{X} \cdot \text{curl } \mathbf{X} = 0$ is equivalent to the relation

$$\frac{\partial(U, K)}{\partial(x, y)} = 0$$

From Theorem 3 it follows that there exists between U and K a relation independent of x and y but not necessarily of z . In other words, K can be expressed as a function $K(U, z)$ of U and z alone, and equation (11) is of the form

$$\frac{dU}{dz} + K(U, z) = 0$$

which, by Theorem 2, has a solution of the form

$$\Phi(U, z) = c$$

where c is an arbitrary constant. On replacing U by its expression in terms of x , y , and z , we obtain the solution in the form

$$F(x, y, z) = c$$

showing that the original equation (6) is integrable.

Once it has been established that the equation is integrable, it only remains to determine an appropriate integrating factor $\mu(x, y, z)$. We shall discuss the solution of Pfaffian differential equations in three variables more fully in the next section. Before going on to the discussion of methods of solution, we shall first of all prove a theorem on integrating factors of Pfaffian differential equations which is of great importance in thermodynamics. Since the proof is elementary, we shall state the result generally for an equation in n variables:

Theorem 6. *Given one integrating factor of the Pfaffian differential equation*

$$X_1 dx_1 + X_2 dx_2 + \cdots + X_n dx_n = 0$$

we can find an infinity of them.

For, if $\mu(x_1, x_2, \dots, x_n)$ is an integrating factor of the given equation, there exists a function $\phi(x_1, x_2, \dots, x_n)$ with the property that

$$\mu X_i = \frac{\partial \phi}{\partial x_i} \quad i = 1, 2, \dots, n \quad (13)$$

If $\Phi(\phi)$ is an arbitrary function of ϕ , we find that the given Pfaffian differential equation may be written in the form

$$\mu \frac{d\Phi}{d\phi} (X_1 dx_1 + X_2 dx_2 + \dots + X_n dx_n) = 0$$

which, by virtue of the relations (13), is equivalent to

$$\frac{d\Phi}{d\phi} \left(\frac{\partial \phi}{\partial x_1} dx_1 + \frac{\partial \phi}{\partial x_2} dx_2 + \dots + \frac{\partial \phi}{\partial x_n} dx_n \right) = 0$$

i.e., to

$$\frac{d\Phi}{d\phi} d\phi = d\Phi = 0$$

with solution

$$\Phi(\phi) = c$$

Thus if μ is an integrating factor yielding a solution $\phi = c$ and if Φ is an arbitrary function of ϕ , then $\mu(d\Phi/d\phi)$ is also an integrating factor of the given differential equation. Since Φ is arbitrary, there are infinitely many integrating factors of this type.

To show how the theoretical argument outlined in the proof of Theorem 5 may be used to derive the solution of a Pfaffian differential equation we shall consider:

Example 6. *Verify that the differential equation*

$$(y^2 + yz) dx + (xz + z^2) dy + (y^2 - xy) dz = 0$$

is integrable and find its primitive.

First of all to verify the integrability we note that in this case

$$\mathbf{X} = (y^2 + yz, xz + z^2, y^2 - xy)$$

so that $\text{curl } \mathbf{X} = 2(-x + y + z, y, -y)$

and it is readily verified that

$$\mathbf{X} \cdot \text{curl } \mathbf{X} = 0$$

If we treat z as a constant, the equation reduces to

$$\frac{dx}{x + z} + \frac{dy}{y} + \frac{dy}{y + z} = 0$$

which has solution $U(x, y, z) = c_1$, where

$$U(x, y, z) = \frac{y(x + z)}{y + z}$$

Now

$$\mu = \frac{1}{P} \frac{\partial U}{\partial x} = \frac{1}{y(y + z)} \cdot \frac{y}{y + z} = \frac{1}{(y + z)^2}$$

and, in the notation of equation (12),

$$K = \frac{1}{(y + z)^2} \cdot y(1 - xy) + \frac{1}{y + z} + \frac{y(x + z)}{(y + z)^2} = 0$$

If $K = 0$, equation (11) reduces to the simple form $dU = 0$ with solution $U = c$; i.e., the solution of the original equation is

$$y(x) = z(x) = c(y = z)$$

where c is a constant.

It is of interest to consider the geometrical meaning of integrability. The functions $y = y(x)$, $z = z(x)$ constitute a solution of the equation

$$P dx + Q dy + R dz = 0 \quad (14)$$

if they reduce the equation to an identity in x . Geometrically such a solution is a curve whose tangential direction τ at the point $X(x, y, z)$ is perpendicular to the line λ whose direction cosines are proportional to (P, Q, R) (cf. Fig. 9), and hence the tangent to an integral curve lies in the disk σ which is perpendicular to λ and whose center is (x, y, z) . On the other hand, a curve through the point X is an integral curve of the equation if its tangent at X lies in σ . When the equation is integrable, the integral curves lie on the one-parameter family of surfaces

$$d(x, y, z) = c$$

where a curve on one of these surfaces automatically is an integral curve of the equation (14). The condition of integrability may therefore

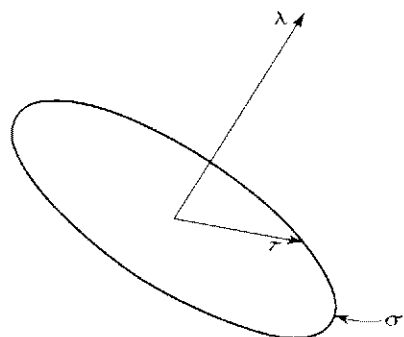

Figure 9

be thought of as the condition that the disks σ should fit together to form a one-parameter family of surfaces.

Another way of looking at it is to say that the equation (14) is integrable if there exists a one-parameter family of surfaces orthogonal to the two-parameter system of curves determined by the equations

$$\frac{dx}{P} = \frac{dy}{Q} = \frac{dz}{R}$$

When the equation is not integrable, it still has solutions in the following sense. It determines on a given surface S with equation

$$U(x, y, z) = 0 \quad (15)$$

a one-parameter system of curves. For, eliminating z from equations (14) and (15), we have a first-order ordinary differential equation whose solution

$$\psi(x, y, c) = 0$$

is a one-parameter system of cylinders C_1, C_2, \dots (cf. Fig. 10) with generators parallel to Oz and cutting the surface S in the integral curves $\Gamma_1, \Gamma_2, \dots$.

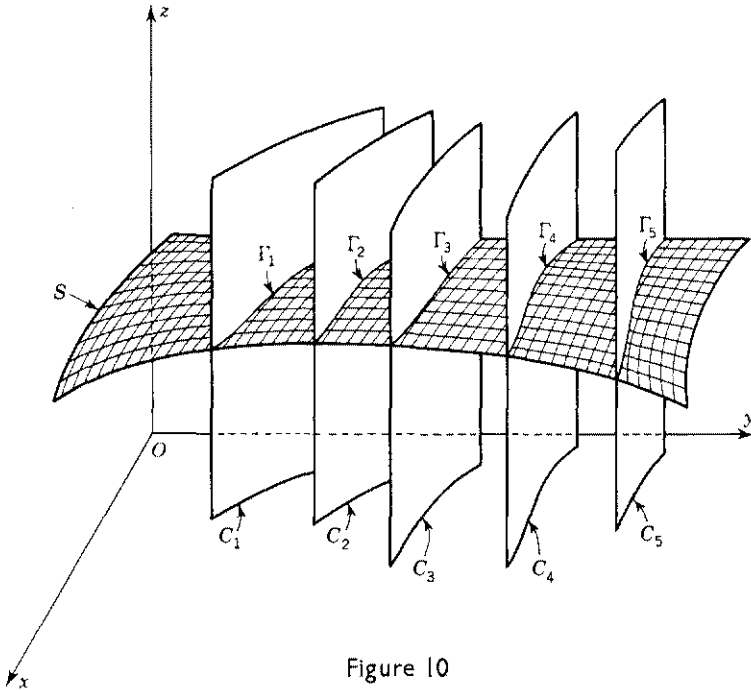

Figure 10

PROBLEMS

Determine which of the following equations are integrable, and find the solution of those which are:

1. $y dx + x dy + 2z dz = 0$
2. $z(z + y) dx + z(z + x) dy - 2xy dz = 0$
3. $yz dx + 2xz dy - 3xy dz = 0$
4. $2xz dx + z dy - dz = 0$
5. $(y^2 - xz) dx + (x^2 + yz) dy - 3z^2 dz = 0$

6. Solution of Pfaffian Differential Equations in Three Variables

We shall now consider methods by which the solutions of Pfaffian differential equations in three variables x, y, z may be derived.

(a) *By Inspection.* Once the condition of integrability has been verified, it is often possible to derive the primitive of the equation by inspection. In particular if the equation is such that $\text{curl } \mathbf{X} = \mathbf{0}$, then¹

¹ *Ibid.*, p. 46.

\mathbf{X} must be of the form $\text{grad } v$, and the equation $\mathbf{X} \cdot d\mathbf{r} = 0$ is equivalent

$$\frac{\partial v}{\partial x} dx + \frac{\partial v}{\partial y} dy + \frac{\partial v}{\partial z} dz = 0$$

with primitive

$$v(x, y, z) = c$$

Example 7. Solve the equation

$$(x^2z - y^3) dx - 3xy^2 dy + x^3 dz = 0$$

by showing that it is integrable.

To test for integrability we note that $\mathbf{X} = (x^2z - y^3, -3xy^2, x^3)$, so that $\text{curl } \mathbf{X} = (0, -2x^2, 6y^2)$, and hence $\mathbf{X} \cdot \text{curl } \mathbf{X} = 0$.

We may write the equation in the form

$$x^2(z dx + x dz) - y^3 dx - 3xy^2 dy = 0$$

$$\text{i.e.} \quad z dx + x dz - \frac{y^3}{x^2} dx + \frac{3y^2}{x} dy = 0$$

$$\text{i.e.} \quad d(xz) - d\left(\frac{y^3}{x}\right) = 0$$

so that the primitive of the equation is

$$x^2z + y^3 = cx$$

where c is a constant.

(b) *Variables Separable.* In certain cases it is possible to write the Pfaffian differential equation in the form

$$P(x) dx + Q(y) dy + R(z) dz = 0$$

in which case it is immediately obvious that the integral surfaces are given by the equation

$$\int P(x) dx + \int Q(y) dy + \int R(z) dz = c$$

where c is a constant.

Example 8. Solve the equation

$$a^2y^2z^2 dx + b^2z^2x^2 dy + c^2x^2y^2 dz = 0$$

If we divide both sides of this equation by $x^2y^2z^2$, we have

$$\frac{a^2}{x^2} dx + \frac{b^2}{y^2} dy + \frac{c^2}{z^2} dz = 0$$

showing that the integral surfaces are

$$\frac{a^2}{x} + \frac{b^2}{y} + \frac{c^2}{z} = k$$

where k is a constant.

(c) *One Variable Separable.* It may happen that one variable is separable, z say, in which case the equation is of the form

$$P(x,y) dx + Q(x,y) dy + R(z) dz = 0 \quad (1)$$

For this equation

$$\mathbf{X} = \{P(x,y), Q(x,y), R(z)\}$$

and a simple calculation shows that

$$\text{curl } \mathbf{X} = \left(0, 0, \frac{\partial Q}{\partial x} - \frac{\partial P}{\partial y}\right)$$

so that the condition for integrability, $\mathbf{X} \cdot \text{curl } \mathbf{X} = 0$, implies that

$$\frac{\partial P}{\partial y} = \frac{\partial Q}{\partial x}$$

In other words, $P dx + Q dy$ is an exact differential, du say, and equation (1) reduces to

$$du + R(z) dz = 0$$

with primitive

$$u(x,y) + \int R(z) dz = c$$

Example 9. Verify that the equation

$$x(y^2 - a^2) dx + y(x^2 - z^2) dy - z(y^2 - a^2) dz = 0$$

is integrable and solve it.

If we divide throughout by $(y^2 - a^2)(x^2 - z^2)$, we see that the equation assumes the form

$$\frac{x dx - z dz}{x^2 - z^2} + \frac{y dy}{y^2 - a^2} = 0$$

showing that it is separable in y . By the above argument it is therefore integrable if

$$\frac{\partial P}{\partial z} = \frac{\partial R}{\partial x}$$

which is readily shown to be true. To determine the solution of the equation we note that it is

$$\frac{1}{2} d \log(x^2 - z^2) + \frac{1}{2} d \log(y^2 - a^2) = 0$$

so that the solution is

$$(x^2 - z^2)(y^2 - a^2) = c$$

where c is a constant.

(d) *Homogeneous Equations.* The equation

$$P(x,y,z) dx + Q(x,y,z) dy + R(x,y,z) dz = 0 \quad (2)$$

is said to be homogeneous if the functions P , Q , R are homogeneous in x , y , z of the same degree n . To derive the solution of such an equation we make the substitutions

$$y = ux, \quad z = vx \quad (3)$$

stituting from (3) into (2), we see that equation (2) assumes the form

$$P(1, u, v) dx + Q(1, u, v)(u dx + x du) + R(1, u, v)(x dv + v dx) = 0$$

factor x^n canceling out. If we now write

$$A(u, v) = \frac{Q(1, u, v)}{P(1, u, v) + uQ(1, u, v) + vR(1, u, v)}$$

$$B(u, v) = \frac{R(1, u, v)}{P(1, u, v) + uQ(1, u, v) + vR(1, u, v)}$$

we find that this equation is of the form

$$\frac{dx}{x} + A(u, v) du + B(u, v) dv = 0$$

which can be solved by method (c).

It is obvious from the above analysis that another way of putting the same result is to say that if the condition of integrability is satisfied and if P , Q , R are homogeneous functions of x , y , z of the same degree and if $xP + yQ + zR$ does not vanish identically, its reciprocal is an integrating factor of the given equation.

Example 10. Verify that the equation

$$yz(y + z) dx + xz(x + z) dy + xy(x + y) dz = 0$$

is integrable and find its solution.

It is easy to show that the condition of integrability is satisfied; this will be left as an exercise to the reader. Making the substitutions $y = ux$, $z = vx$, we find the equation satisfied by x , u , v is

$$u(u + v) dx + v(v + 1)(u dx + x du) + u(u + 1)(v dx + x dv) = 0$$

which reduces to

$$\frac{dx}{x} + \frac{v(v + 1) du + u(u + 1) dv}{2uv(1 + u + v)} = 0$$

Putting the factors of du and dv into partial fractions, we see that this is equivalent to

$$2 \frac{dx}{x} + \left\{ \frac{1}{u} - \frac{1}{1 + u + v} \right\} du + \left\{ \frac{1}{v} - \frac{1}{1 + u + v} \right\} dv = 0$$

which is the same thing,

$$2 \frac{dx}{x} + \frac{du}{u} - \frac{dv}{v} - \frac{d(1 + u + v)}{1 + u + v} = 0$$

The solution of this equation is obviously

$$x^2 uv = c(1 + u + v)$$

where c is a constant. Reverting to the original variables, we see that the solution of the given equation is

$$xyz = c(x + y + z)$$

(e) *Natani's Method.* In the first instance we treat the variable z as though it were constant, and solve the resulting differential equation

$$P dx + Q dy = 0$$

Suppose we find that the solution of this equation is

$$\phi(x, y, z) = c_1 \quad (4)$$

where c_1 is a constant. The solution of equation (2) is then of the form

$$\Phi(\phi, z) = c_2 \quad (5)$$

where c_2 is a constant, and we can express this solution in the form

$$\phi(x, y, z) = \psi(z)$$

where ψ is a function of z alone. To determine the function $\psi(z)$ we observe that, if we give the variable x a fixed value, α say, then

$$\phi(\alpha, y, z) = \psi(z) \quad (6)$$

is a solution of the differential equation

$$Q(x, y, z) dy + R(x, y, z) dz = 0 \quad (7)$$

Now we can find a solution of equation (7) in the form

$$\kappa(y, z) = c \quad (8)$$

by using the methods of the theory of first-order differential equations.

Since equations (6) and (8) represent general solutions of the same differential equation (7), they must be equivalent. Therefore if we eliminate the variable y between (6) and (8), we obtain an expression for the function $\psi(z)$. Substituting this expression in equation (6), we obtain the solution of the Pfaffian differential equation (2).

The method is often simplified by choosing a value for α , such as 0 or 1, which makes the labor of solving the differential equation (7) as light as possible. It is important to remember that it is necessary to verify in advance that the equation is integrable before using Natani's method.

Example 11. *Verify that the equation*

$$z(z + y^2) dx + z(z + x^2) dy + xy(x + y) dz = 0$$

is integrable and find its primitive.

For this equation

$$\mathbf{X} = \{z(z + y^2), z(z + x^2), -xy(x + y)\}$$

$$\text{curl } \mathbf{X} = 2(-x^2 - xy - z, y^2 + xy - z, zx - zy)$$

and it is soon verified that $\mathbf{X} \cdot \text{curl } \mathbf{X} = 0$, showing that the equation is integrable.

An inspection of the equation suggests that it is probably simplest to take $dy = 0$ in Natani's method. The equation then becomes

$$\left(\frac{1}{x} - \frac{1}{x + y} \right) dx + \left(\frac{1}{z + y^2} - \frac{1}{z} \right) dz = 0$$

g that it has the solution

$$\frac{x(y^2 - z)}{z(x - y)} = f(y) \quad (9)$$

we now let $z = 1$ in the original equation, we see that it reduces to the simple

$$\frac{dx}{1 - x^2} - \frac{dy}{1 - y^2} = 0 \quad (10)$$

solution

$$\tan^{-1} x - \tan^{-1} y = \text{const.}$$

By putting $\tan^{-1}(1/c)$ for the constant and making use of the addition formula

$$\tan^{-1} x - \tan^{-1} y = \tan^{-1} \frac{x - y}{1 + xy}$$

we see that the solution of equation (10) is

$$\frac{1 - xy}{x + y} = c \quad (11)$$

The solution must be the form assumed by (9) in the case $z = 1$; in other words, (11) must be equivalent to the relation

$$\frac{x(y^2 - 1)}{x - y} = f(y) \quad (12)$$

By eliminating x between equations (11) and (12), we find that

$$f(y) = 1 - cy$$

By putting this expression in equation (9), we find that the solution of the original equation is

$$x(y^2 - z) = z(x + y)(1 - cy)$$

3.1. Reduction to an Ordinary Differential Equation. In this method we reduce the problem of finding the solution of a Pfaffian differential equation of the type (2) to that of integrating *one* ordinary differential equation of the first order in two variables. It is necessary, of course, that the condition for integrability should be satisfied.

If the equation (2) is integrable, it has a solution of the form

$$f(x, y, z) = c \quad (13)$$

representing a one-parameter family of surfaces in space. These integral surfaces will be intersected in a single infinity of curves by the plane

$$z = x + ky \quad (14)$$

where k is a constant. The curves so formed will be the solutions of the differential equation

$$p(x, y, k) dx + q(x, y, k) dy = 0 \quad (15)$$

formed by eliminating z between equations (2) and (14).

If we have found the solution of the ordinary differential equation (15), we may easily find the family of surfaces (13), since we know their curves of intersection with planes of the type (14). For the single infinity of curves of intersection which pass through one point on the axis of the family of planes obtained by varying k in (14) will in general form one of the integral surfaces (13).

Suppose that the general solution of equation (15) is

$$\phi(x, y, k) = \text{const.} \quad (16)$$

then, since a point on the axis of the planes (13) is determined by $y = 0$, $x = c$ (a constant), we must have

$$\phi(x, y, k) = \phi(c, 0, k) \quad (17)$$

in order that the curves (16) should pass through this point. When k varies, (17) represents the family of curves through the point $y = 0$, $x = c$. If c also varies, we obtain successively the family of curves through each point on the axis of (14). That is, if we eliminate k between equations (17) and (13), we obtain the integral surfaces required in the form

$$\phi\left(x, y, \frac{z-x}{y}\right) = \phi\left(c, 0, \frac{z-x}{y}\right) \quad (18)$$

The complete solution of the Pfaffian differential equation (2) is therefore determined once we know the solution (16) of one ordinary differential equation of the first order, namely, (15). If it so happens that the constant k is a factor of equation (15), then we must use some other family of planes in place of (14).

Theoretically, this method is superior to Natani's method in that it involves the solution of *one* ordinary differential in two variables instead of two as in the previous case. On the other hand, this one equation is often more difficult to integrate than either of the equations in Natani's method.

Example 12. *Integrate the equation*

$$(y+z) dx + (z+x) dy - (x-y) dz = 0$$

The integration of this equation could be effected in a number of ways—by methods (a), (d), (e), for instance—but we shall illustrate method (f) by applying it in this case.

Putting $z = x - ky$, we find that the equation reduces to the form

$$\frac{dy}{dx} + \frac{2x + (k+2)y}{(k+2)x + 2ky} = 0$$

which is homogeneous in x and y . Making the substitution $y = vx$, we find that

$$2 \frac{dx}{x} + \frac{\{2kv - (k+2)\} dv}{kx^2 \cdot (k+2)v - 1} = 0$$

$$x^2 \{kv^2 - (k+2)v - 1\} = \text{const.}$$

therefore

$$\phi(x, y, k) = ky^2 + (k+2)xy + x^2$$

shows immediately that

$$\phi\left(x, y, \frac{z-x}{y}\right) = xy + yz + zx$$

$$\phi\left(c, 0, \frac{z-x}{y}\right) = c^2$$

Putting C for c^2 , we obtain the solution

$$xy + yz + zx = C$$

PROBLEMS

Verify that the following equations are integrable and find their primitives:

1. $2z(a-x) dx + [z-y^2 + (a-x)^2] dy - y dz = 0$
2. $(1+z^2) dx - x(1+z^2) dy + (x^2+y^2) dz = 0$
3. $(x^2-yz+z^2) dx + (z^2+zx+x^2) dy + (x^2-xy+y^2) dz = 0$
4. $yz dx - xz dy + xy dz = 0$
5. $(1-yz) dx + x(z-x) dy - (1-xy) dz = 0$
6. $(x+4)(y+z) dx - x(y+3z) dy + 2xy dz = 0$
7. $yz dx + (x^2y-zx) dy + (x^2z-xy) dz = 0$
8. $2xz dx - 2xz dy - (x^2-y^2)(z-1) dz = 0$

7. Carathéodory's Theorem

The importance of the analysis of Sec. 5 is that it shows that we cannot, in general, find integrating factors for Pfaffian differential forms in more than two independent variables. Our discussion has shown that Pfaffian differential forms fall into two classes, those which are integrable and those which are not. This difference is too abstract to be of immediate use in thermodynamical theory, and it is necessary to seek a more geometrical characterization of the difference between the two classes of Pfaffian forms.

Before considering the case of three variables, we shall consider the case of a Pfaffian differential form in two variables. As a first example take the Pfaffian equation

$$dx - dy = 0$$

which obviously has the solution

$$x - y = c \tag{1}$$

where c is a constant. Geometrically this solution consists of a family of straight lines all making an angle $\pi/4$ with the positive direction of the x axis. Consider now the point $(0,0)$. The only line of the family which passes through this point is the line $x = y$. This line intersects the circle $x^2 + y^2 = \varepsilon^2$ in two points

$$A\left(\frac{\varepsilon}{\sqrt{2}}, \frac{\varepsilon}{\sqrt{2}}\right) \quad \text{and} \quad B\left(-\frac{\varepsilon}{\sqrt{2}}, -\frac{\varepsilon}{\sqrt{2}}\right)$$

Now it is not possible to go from A to any point on the circle, other than B , if we restrict the motion to be always along lines of the family (1). Thus, since ϵ may be made as small as we please, it follows that arbitrarily close to the point $(0,0)$ there is an infinity of points which cannot be reached by means of lines which are solutions of the given Pfaffian differential equation.

This result is true of the general Pfaffian differential equation in two variables. By Theorem 2 there exists a function $\phi(x,y)$ and a function $\mu(x,y)$ such that

$$\mu(x,y)\{P(x,y) dx + Q(x,y) dy\} = d\phi(x,y)$$

so that the equation

$$P dx + Q dy = 0$$

must possess an integral of the form

$$\phi(x,y) = c \tag{2}$$

where c is a constant. Thus through every point of the xy plane there passes one, and only one, curve of the one-parameter system (2). From any given point in the xy plane we cannot reach *all* the neighboring points by curves which satisfy the given differential equation. We shall refer to this state of affairs by the statement that not all the points in the neighborhood are *accessible* from the given point.

A similar result holds for a Pfaffian differential equation in three independent variables. If the equation possesses an integrating factor, the situation is precisely the same as in the two-dimensional case. All the solutions lie on one or other of the surfaces belonging to the one-parameter system

$$\phi(x,y,z) = c$$

so that we cannot reach *all* the points in the neighborhood of a given point but only those points which lie on the surface of the family passing through the point we are considering.

By extending the idea of inaccessible points to space of n dimensions we may similarly prove:

Theorem 7. *If the Pfaffian differential equation*

$$\Delta X = X_1 dx_1 + X_2 dx_2 + \cdots + X_n dx_n = 0$$

is integrable, then in any neighborhood, however small, of a given point G_0 , there exists points which are not accessible from G_0 along any path for which $\Delta X = 0$.

What is of interest in thermodynamics is not the direct theorem but the converse. That is, we consider whether or not the inaccessibility of points in the neighborhood of a given point provides us with a criterion for the integrability of the Pfaffian differential equation. If we know that in the neighborhood of a given point there are points which are

only near but inaccessible along curves for which $\Delta X = 0$, can we assert that the Pfaffian differential equation $\Delta X = 0$ possesses an integrating factor? Carathéodory has shown that the answer to this question is in the affirmative. Stated formally his theorem is:

Theorem 8. *If a Pfaffian differential form $\Delta X = X_1 dx_1 + X_2 dx_2 + \dots + X_n dx_n$ has the property that in every arbitrarily close neighborhood of a given point G_0 there exist points G which are inaccessible from G_0 by curves for which $\Delta X = 0$, the corresponding Pfaffian differential form $\Delta X = 0$ is integrable.*

We shall consider the proof of this theorem in the case $n = 3$. The geometrical concepts are simpler in this case, and the extension to a larger number of independent variables is purely formal.

First of all we shall prove the theorem making use of a method suggested by a paper of Buchdahl's.¹ This depends essentially on the fact that by means of the transformations (10) and (12) of Sec. 5 the Pfaffian form

$$P dx + Q dy + R dz = 0 \quad (3)$$

can be written in the form

$$\frac{dU}{dz} + K(U, y, z) = 0 \quad (4)$$

in which, it will be observed, the function K may be expressed as a function of the *three* variables U , y , and z . If we take y to be *fixed*, we may write equation (4) in the form

$$dU + K(U, y, z) dz = 0$$

which, by Theorem 2 has a solution of the form

$$U = \phi(z, y) \quad (5)$$

As we showed in Sec. 5 that equation (3) was integrable if it could be written in the form

$$\frac{dU}{dz} + K(U, z) = 0 \quad (6)$$

if and only if,

$$\frac{\partial \phi}{\partial y} = 0 \quad (7)$$

in a certain region of the yz plane.

Suppose the point $G_0(x_0, y_0, z_0)$ is contained in a domain D of the three-dimensional space. Then if P , Q , R , and μ are such that Y and K are single-valued, finite, and continuous functions of x , y , and z , there is a one-to-

¹A. Buchdahl, *Am. J. Phys.*, **17**, 44 (1949).

one correspondence between the points of D and those of a domain D' of the Uyz space. Let $H_0(U_0, y_0, z_0)$ be the point of D' corresponding to the point G_0 of D . We shall now consider how the passage along a solution curve of equation (6) from H_0 to a neighboring point H may actually be effected:

(a) First pass in the plane $y = y_0$ from H_0 to the point H_1 ; then by virtue of (5) the coordinates of H_1 will be $\{\phi(z_0 + \zeta', y_0), y_0, z_0 + \zeta'\}$, where ζ' denotes the displacement in the z coordinate. Furthermore since H_0 lies on the same integral curve as H_1 , it follows that

$$U_0 = \phi(z_0, y_0)$$

(b) Next pass in the plane $U = \phi(z_0 + \zeta', y_0)$ from H_1 to the point H_2 . Since z is constant, it follows that the coordinates of H_2 are

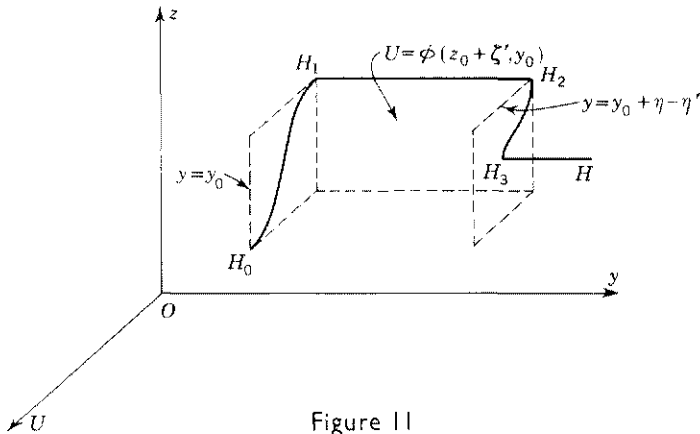

Figure 11

$\{\phi(z_0 + \zeta', y_0), y_0 + \eta - \eta', z_0 + \zeta'\}$, where $\eta - \eta'$ denotes the displacement H_1H_2 .

(c) Next pass in the plane $y = y_0 + \eta - \eta'$ to the point H_3 , which then has coordinates $\{\phi(z_0 + \zeta, y_0 + \eta - \eta'), y_0 + \eta - \eta', z_0 + \zeta\}$, $\zeta - \zeta'$ denoting the change in the z coordinate.

(d) Finally pass in the plane $U = \phi(z_0 + \zeta, y_0 + \eta - \eta')$ through a displacement η' to the point H , which then has coordinates

$$U = \phi(z_0 + \zeta, y_0 + \eta - \eta'), \quad y = y_0 + \eta, \quad z = z_0 + \zeta$$

If the point $(U_0 + \epsilon_1, y_0 + \epsilon_2, z_0 + \epsilon_3)$, which is arbitrarily close to $H_0(U_0, y_0, z_0)$, is accessible from H_0 along solutions of the equation (4), then it is possible to choose the displacement η, η', ζ in such a way that

$$\phi(z_0 + \zeta, y_0 + \eta - \eta') - \phi(z_0, y_0) = \epsilon_1, \quad \eta = \epsilon_2, \quad \zeta = \epsilon_3 \quad (8)$$

Now if *all* the points in the neighborhood of H_0 are accessible from H_0 ,

It follows that the points $(U_0 + \epsilon, V_0, z_0)$ which lie on the line $x = x_0$, $z = z_0$, are accessible from H_0 . Therefore it should be possible to find a displacement u' such that

$$\{\phi(z_0, y_0 + u') - \phi(z_0, V_0)\} = \epsilon \quad (9)$$

this is so only if $\partial\phi/\partial y$ is not identically zero, in which case, as we remarked above, the equation is not integrable.

On the other hand if there are points which are inaccessible from H_0 , it follows that there exist values of ϵ_1 , ϵ_2 , and ϵ_3 for which the equations (8) or what is the same thing, equation (9)—have no solution. To the first order we may write equation (9) in the form

$$(\epsilon_2 + u') \left(\frac{\partial\phi}{\partial y} \right)_{y=y_0} = \epsilon_1 + \epsilon_2 \left(\frac{\partial\phi}{\partial z} \right)_{z=z_0}$$

It fails to give a value for u' , it can only be because

$$\left(\frac{\partial\phi}{\partial y} \right)_{y=y_0} = 0$$

and only if the equation is integrable.

A more geometrical proof of Carathéodory's theorem has been given by Born.¹ In this proof we consider the solutions of the Pfaffian differential equation (3) which lie on a given surface S with parametric equations

$$x = x(u, v), \quad y = y(u, v), \quad z = z(u, v)$$

These curves will satisfy the two-dimensional Pfaffian differential equation

$$F du + G dv = 0 \quad (10)$$

and

$$F = P \frac{\partial x}{\partial u} + Q \frac{\partial y}{\partial u} + R \frac{\partial z}{\partial u}, \quad G = P \frac{\partial x}{\partial v} + Q \frac{\partial y}{\partial v} + R \frac{\partial z}{\partial v}$$

Now, by Theorem 2, equation (10) has a solution of the form

$$\phi(u, v) = 0$$

representing a one-parameter system of curves covering the surface S . We now suppose that arbitrarily close to a given point G_0 there are accessible points, and let us further assume that G is one of these points. Through G_0 draw a line λ which is not a solution of equation (10) and which does not pass through G . Let π be the plane defined by the line λ and the point G .

¹M. Born, "Natural Philosophy of Cause and Chance" (Oxford, London, 1949), Appendix 7, p. 144.

If we now take the plane π to be the surface S , introduced above, we see that there is just one curve which lies in the plane π , passes through the point G , and is a solution of equation (3). Suppose this curve intersects the line λ in the point H ; then since G is accessible from H and inaccessible from G_0 , it follows that H is inaccessible from G_0 . Furthermore, since we can choose a point G arbitrarily close to G_0 , the point H may be arbitrarily near to G_0 .

Suppose now that the line λ is made to move parallel to itself to generate a closed cylinder σ . Then on the surface σ there exists a

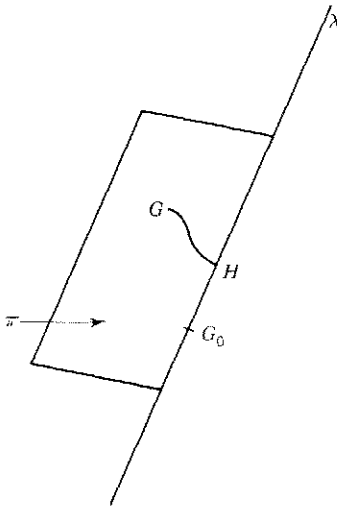

Figure 12

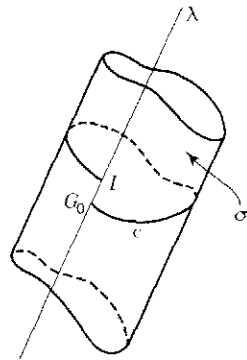

Figure 13

curve c which is a solution of (3) and passes through G_0 . If the line λ cuts the curve c again in a point I , then by continuously deforming the cylinder σ we can make the point I move along a segment of the line λ surrounding the point G_0 . In this way we could construct a band of accessible points in the vicinity of G_0 . But this is contrary to the assumption that, arbitrarily close to G_0 , there exist points on the line λ (such as H) which are inaccessible from G_0 ; hence we conclude that for each form of σ the point I coincides with G_0 .

As the cylinder σ is continuously deformed, the closed curve c traces out a surface which contains all solutions of the equation (3) passing through the point G_0 . Since this surface will have an equation of the form

$$\phi(x, y, z) = \phi(x_0, y_0, z_0)$$

it follows that there exist functions μ and ϕ such that

$$\mu(P dx + Q dy + R dz) = d\phi$$

and so the theorem is proved.

Application to Thermodynamics

Most elementary textbooks on thermodynamics follow the historical development of the subject and consequently discuss the basic principles and forms of the behavior of several kinds of "perfect" heat engines. This is no doubt advantageous in the training of engineers, but mathematicians and physicists often feel a need for a more formal approach. The more elegant, and at the same time more rational, formulation of the foundations of thermodynamics has been developed by Carathéodory on the basis of Theorem 8, and will be outlined here. For the full details the reader is referred to the original papers.¹

The first law of thermodynamics is essentially a generalization of Joule's experimental law that whenever heat is generated by mechanical means, the heat evolved is always in a constant ratio to the corresponding amount of work done by the forces. There are several ways in which such a generalization may be framed. That favored by Carathéodory is:

In order to bring a thermodynamical system from a prescribed initial state to another prescribed final state adiabatically, it is necessary to do a certain amount of mechanical work which is independent of the manner in which the change is accomplished and which depends only on the prescribed initial and final states of the system.

It will be observed that in this axiom the idea of quantity of heat is regarded, as it is in the classical theory of Clausius and Kelvin, as an intuitive one; an adiabatic process can be thought of as one taking place in an adiabatic enclosure defined by the property that the final state of any thermodynamical system enclosed within it can be reached only by displacing a finite area of the wall of the enclosure.

Schematically this first law is equivalent to saying that in such an adiabatic process the mechanical work done W is a function of the thermodynamical variables (x_1, x_2, \dots, x_n) and $(x_1^{(i)}, x_2^{(i)}, \dots, x_n^{(i)})$ defining the final and initial states of the system and not of the intermediate values of these variables. Thus we may write

$$W = W(x_1, x_2, \dots, x_n; x_1^{(i)}, x_2^{(i)}, \dots, x_n^{(i)})$$

If we consider a simple experiment in which the substance goes from an initial state $(x_1^{(i)}, \dots, x_n^{(i)})$ to an intermediate state $(x_1^{(j)}, \dots, x_n^{(j)})$ and then to a final state (x_1, \dots, x_n) , we obtain the functional equation

$$\begin{aligned} W(x_1, \dots, x_n; x_1^{(i)}, \dots, x_n^{(i)}) &+ W(x_1^{(j)}, \dots, x_n^{(j)}; x_1^{(i)}, \dots, x_n^{(i)}) \\ &= W(x_1, \dots, x_n; x_1^{(j)}, \dots, x_n^{(j)}) \end{aligned}$$

¹ Carathéodory, *Math. Ann.*, **67**, 355 (1909); *Sitzber. preuss. Akad. Wiss. phys.-math. Kl.*, **1925**, p. 39. General accounts of Carathéodory's theory are given in M. Born, *Physik. Z.*, **22**, 218, 249, 282 (1921); A. Landé, "Handbuch der Physik" (Springer, Berlin, 1936), vol. 9, chap. IV.

for the determination of the function W . This shows that there exists a function $U(x_1, \dots, x_n)$, called the *internal energy* of the system, with the property that

$$W(x_1, \dots, x_n; x_1^{(0)}, \dots, x_n^{(0)}) = U(x_1, \dots, x_n) - U(x_1^{(0)}, \dots, x_n^{(0)}) \quad (1)$$

If we now consider the case in which the state of the system is changed from $(x_1^{(0)}, \dots, x_n^{(0)})$ to (x_1, \dots, x_n) by applying an amount of work W , but *not* ensuring that the system is adiabatically enclosed, we find that the change in internal energy $U(x_1, \dots, x_n) - U(x_1^{(0)}, \dots, x_n^{(0)})$, which can be determined experimentally by measuring the amount of work necessary to achieve it when the system is adiabatically enclosed, will not equal the mechanical work W . The difference between the two quantities is defined to be the *quantity of heat* Q absorbed by the system in the course of the nonadiabatic process. Thus the first law of thermodynamics is contained in the equation

$$Q = U - U_0 - W \quad (2)$$

In Carathéodory's theory the idea of quantity of heat is a derived one which has no meaning apart from the first law of thermodynamics.

A gas, defined by its pressure p and its specific volume v , is the simplest kind of thermodynamical system we can consider. It is readily shown that if the gas expands by an infinitesimal amount dv , the work done by it is $-p dv$, and this is *not* an exact differential. Hence we should denote the work done in an infinitesimal change of the system by ΔW . On the other hand it is obvious from the definition of U that the change in the internal energy in an infinitesimal change of the system is an exact differential, and should be denoted by dU . Hence we may write (2) in the infinitesimal form

$$\Delta Q = dU - \Delta W \quad (3)$$

If we take p and v as the thermodynamical variables and put $\Delta W = -p dv$, then for a gas

$$\Delta Q = P dp + V dv \quad (4)$$

where $P = \frac{\partial U}{\partial p}$, $V = \frac{\partial U}{\partial v} + p$

Now from Theorem 2 we have immediately that, whatever the forms of the functions P and V , there exist functions $\mu(p, v)$ and $\phi(p, v)$ such that

$$\mu \Delta Q = d\phi \quad (5)$$

showing that, although ΔQ is not itself an exact differential, it is always possible to find a function μ of the thermodynamical variables such

that $\mu \Delta Q$ is an exact differential. This result is a purely mathematical consequence of the fact that two thermodynamical variables are sufficient for the unique specification of the system.

It is natural to inquire whether or not such a result is valid when the system requires more than two thermodynamical variables for its complete specification. If the system is described by the n thermodynamical variables x_1, x_2, \dots, x_n , then equation (4) is replaced by a Pfaffian form of the type

$$\Delta Q = \sum_{i=1}^n X_i dx_i \quad (6)$$

in which the X_i 's are functions of x_1, \dots, x_n . We know that, in general, functions μ and ϕ with the property $\mu \Delta Q = d\phi$ do not exist in this general case. If we wish to establish that all thermodynamical systems which occur in nature have this property, then we must add a new axiom of a physical character. This new physical assumption is the second law of thermodynamics.

In the classical theory the physical basis of the second law of thermodynamics is the realization that certain changes of state are not physically realizable; e.g., we get statements of the kind "heat cannot flow from a cold body to a hotter one without external control." In formulating the second law, Carathéodory generalizes such statements and then makes use of Theorem 8 to obtain mathematical relationships similar to those derived by Kelvin and Clausius from their hypotheses. The essential point of Carathéodory's theory is that it formulates the results of our experience in a much more general way without loss of any of the mathematical results. Carathéodory's axiom is:

Arbitrarily near to any prescribed initial state there exist states which cannot be reached from the initial state as a result of adiabatic processes.

If the first law of thermodynamics leads to an equation of the type (6) for the system, then the second law in Carathéodory's form asserts that arbitrarily near to the point $(x_1^{(0)}, \dots, x_n^{(0)})$ there exist points (x_1, \dots, x_n) which are not accessible from the initial point along paths for which $\Delta Q = 0$. It follows immediately from Theorem 8 that there exist functions $\mu(x_1, \dots, x_n)$ and $\phi(x_1, \dots, x_n)$ with the property that

$$\mu \Delta Q = d\phi \quad (7)$$

The function ϕ occurring in this equation is called the *entropy* of the thermodynamical system. It can be shown that the function μ is, apart from a multiplicative constant, a function only of the empirical temperature of the system. It is written as $1/T$, and T is called the *absolute temperature* of the system. It can further be demonstrated that the gas-thermometer scale based on the equation of state of a perfect gas defines a temperature which is directly proportional to T ;

by choosing the absolute scale in the appropriate manner we can make the two temperatures equal. With this notation we can write equation (7) in the familiar form

$$\frac{\Delta Q}{T} = d\phi \quad (8)$$

Theorem 8 shows that such an equation is valid only if we introduce a physical assumption in the form of a second law of thermodynamics.

MISCELLANEOUS PROBLEMS

1. Find the integral curves of the equations:

$$(a) \quad \frac{dx}{y^2x - 2x^4} = \frac{dy}{2y^4 - x^2y} = \frac{dz}{2z(x^3 - y^3)}$$

$$(b) \quad \frac{dx}{2xz} = \frac{dy}{2yz} = \frac{dz}{z^2 - x^2 - y^2}$$

$$(c) \quad \frac{dx}{x - y} = \frac{dy}{x + y} = \frac{dz}{-(x + y + 2z)}$$

2. Find the integral curves of the equations

$$\frac{dx}{cy - bz} = \frac{dy}{az - cx} = \frac{dz}{bx - ay}$$

and show that they are circles.

3. Solve the equations

$$\frac{dx}{x^2 - a^2} = \frac{dy}{xy - az} = \frac{dz}{xz + ay}$$

and show that the integral curves are conics.

4. The components of velocity of a moving point (x, y, z) are $(2z - 4x, 2z - 2y, 2x - 2y - 3z)$; determine the path in the general case.

If the initial point is $(5, 1, 1)$, show that as $t \rightarrow \infty$ the limiting point $(1, 2, 2)$ is approached along a parabola in the plane $x + 2y + 2z = 9$.

5. Find the orthogonal trajectories on the cylinder $y^2 = 2z$ of the curves in which it is cut by the system of planes $x + z = c$, where c is a parameter.
6. Show that the orthogonal trajectories on the cone

$$yz - zx + xy = 0$$

of the conics in which it is cut by the system of planes $x - y = c$ are its curves of intersection with the one-parameter family of surfaces

$$(x + y - 2z)^2(x + y - z) = k$$

7. Find the curves on the paraboloid

$$x^2 - y^2 = 2az$$

orthogonal to the system of generators

$$x - y = \lambda z, \quad x + y = \frac{2a}{\lambda}$$

8. Find curves on the cylinder $x^2 + 2y^2 = 2a^2$ orthogonal to one system of circular sections.
9. Show that the curves on the surface $x^2 + y^2 = 2z$ orthogonal to its curves of intersection with the paraboloids $yz = cx$ lie on the cylinders

$$x^2 + 2z^2 + z \log(kz) = 0$$

where k is a parameter.

10. Verify that the following equations are integrable and determine their primitives:

(a) $zy \, dx + zx \, dy - y^2 \, dz = 0$

(b) $(y^2 + z^2) \, dx + xy \, dy + xz \, dz = 0$

(c) $(y + z) \, dx + dy + dz = 0$

(d) $(2xyz + z^2) \, dx - x^2z \, dy - (xz + 1) \, dz = 0$

(e) $zy^2 \, dx + zx^2 \, dy - x^2y^2 \, dz = 0$

(f) $x(y^2 - z^2) \, dx - y(z^2 - x^2) \, dy + z(x^2 - y^2) \, dz = 0$

(g) $(y^2 - z^2) \, dx - (x^2 - z^2) \, dy + (x - y)(x + y - 2z) \, dz = 0$

(h) $(y^2 + yz) \, dx + (xz + z^2) \, dy + (y^2 - xy) \, dz = 0$

(i) $2z(y + z) \, dx - 2xz \, dy + \{(y + z)^2 - x^2 - 2xz\} \, dz = 0$

(j) $(x^2 - xy - yz) \, dx - x(x + z) \, dy - x^2 \, dz = 0$

(k) $yz(1 - 4xz) \, dx - xz(1 + 2xz) \, dy - xy \, dz = 0$

(l) $(2xz + z^2) \, dx + 2yz \, dz - (2x^2 + 2y^2 + xz - 2a^2) \, dz = 0$

(m) $(y \, dx - x \, dy)(a - z) - xy \, dz = 0$

(n) $2x \, dx + (2x^2z + 2yz + 2y^2 + 1) \, dy + dz = 0$

(o) $2xz(y - z) \, dx - z(x^2 + 2z) \, dy + y(x^2 + 2y) \, dz = 0$

11. If $f_1, f_2,$ and f_3 are homogeneous functions of the same degree in $x, y,$ and z and if $xf_1 + yf_2 + zf_3 = 0$, show that the equation $f_1 \, dx + f_2 \, dy + f_3 \, dz = 0$ is integrable.

12. Find the general solution of the equation

$$(12x + 29y)z \, dx - (11x + 12y)z \, dy - (2x^2 + 3xy - 2y^2) \, dz = 0$$

and determine the integral surface which passes through the curve $y = 0, z = x^6$.

13. If L, M, N and P, Q, R are proportional to the direction cosines of two directions tangential to the surface $f(x, y, z) = 0$ at the point (x, y, z) and make equal angles with the z axis, show that

$$(P^2 + Q^2)(Lf_x + Mf_y)^2 = (L^2 + M^2)(Pf_x + Qf_y)^2$$

and deduce that

$$\frac{L}{M} = \frac{P(f_x^2 - f_y^2) + 2Qf_xf_y}{Q(f_y^2 - f_x^2) + 2Pf_xf_y}$$

Hence find the equations of the system of curves on the paraboloid $xy = z$ such that each curve, at its intersection with each generator of the system $x = \lambda, z = \lambda y$, makes with the z axis the same angle as that generator.

14. Find the integral curves of the equation

$$y \, dx - x \, dy + dz = 0$$

on the surface $y = xz$.

Chapter 2

PARTIAL DIFFERENTIAL EQUATIONS OF THE FIRST ORDER

1. Partial Differential Equations

We now proceed to the study of partial differential equations proper. Such equations arise in geometry and physics when the number of independent variables in the problem under discussion is two or more. When such is the case, any dependent variable is likely to be a function of more than one variable, so that it possesses not ordinary derivatives with respect to a single variable but partial derivatives with respect to several variables. For instance, in the study of thermal effects in a solid body the temperature θ may vary from point to point in the solid as well as from time to time, and, as a consequence, the derivatives

$$\frac{\partial \theta}{\partial x}, \quad \frac{\partial \theta}{\partial y}, \quad \frac{\partial \theta}{\partial z}, \quad \frac{\partial \theta}{\partial t},$$

will, in general, be nonzero. Furthermore in any particular problem it may happen that higher derivatives of the types

$$\frac{\partial^2 \theta}{\partial x^2}, \quad \frac{\partial^2 \theta}{\partial x \partial t}, \quad \frac{\partial^3 \theta}{\partial x^2 \partial t}, \text{ etc.}$$

may be of physical significance.

When the laws of physics are applied to a problem of this kind, we sometimes obtain a relation between the derivatives of the kind

$$F\left(\frac{\partial \theta}{\partial x}, \dots, \frac{\partial^2 \theta}{\partial x^2}, \dots, \frac{\partial^2 \theta}{\partial x \partial t}, \dots\right) = 0 \quad (1)$$

Such an equation relating partial derivatives is called a *partial differential equation*.

Just as in the case of ordinary differential equations, we define the *order* of a partial differential equation to be the order of the derivative of highest order occurring in the equation. If, for example, we take θ to be the dependent variable and x , y , and t to be independent variables, then the equation

$$\frac{\partial^2 \theta}{\partial x^2} = \frac{\partial \theta}{\partial t} \quad (2)$$

is a *second-order* equation in two variables, the equation

$$\left(\frac{\partial\theta}{\partial x}\right)^2 + \frac{\partial\theta}{\partial t} = 0 \quad (3)$$

is a *first-order* equation in two variables, while

$$x \frac{\partial\theta}{\partial x} + y \frac{\partial\theta}{\partial y} + \frac{\partial\theta}{\partial t} = 0 \quad (4)$$

is a *first-order* equation in three variables.

In this chapter we shall consider partial differential equations of the first order, i.e., equations of the type

$$F\left(\theta, \frac{\partial\theta}{\partial x}, \dots\right) = 0 \quad (5)$$

In the main we shall suppose that there are two independent variables x and y and that the dependent variable is denoted by z . If we write

$$p = \frac{\partial z}{\partial x}, \quad q = \frac{\partial z}{\partial y} \quad (6)$$

we see that such an equation can be written in the symbolic form

$$f(x, y, z, p, q) = 0 \quad (7)$$

2. Origins of First-order Partial Differential Equations

Before discussing the solution of equations of the type (7) of the last section, we shall examine the interesting question of how they arise. Suppose that we consider the equation

$$x^2 + y^2 + (z - c)^2 = a^2 \quad (1)$$

in which the constants a and c are arbitrary. Then equation (1) represents the set of all spheres whose centers lie along the z axis. If we differentiate this equation with respect to x , we obtain the relation

$$x + p(z - c) = 0$$

while if we differentiate it with respect to y , we find that

$$y + q(z - c) = 0$$

Eliminating the arbitrary constant c from these two equations, we obtain the partial differential equation

$$yp - xq = 0 \quad (2)$$

which is of the first order. In some sense, then, the set of all spheres with centers on the z axis is characterized by the partial differential equation (2).

However, other geometrical entities can be described by the same equation. For example, the equation

$$x^2 + y^2 = (z - c)^2 \tan^2 \alpha \quad (3)$$

in which both of the constants c and α are arbitrary, represents the set of all right circular cones whose axes coincide with the line Oz . If we differentiate equation (3) first with respect to x and then with respect to y , we find that

$$p(z - c) \tan^2 \alpha = x, \quad q(z - c) \tan^2 \alpha = y \quad (4)$$

and, upon eliminating c and α from these relations, we see that for these cones also the equation (2) is satisfied.

Now what the spheres and cones have in common is that they are surfaces of revolution which have the line Oz as axes of symmetry. All surfaces of revolution with this property are characterized by an equation of the form

$$z = f(x^2 + y^2) \quad (5)$$

where the function f is arbitrary. Now if we write $x^2 + y^2 = u$ and differentiate equation (5) with respect to x and y , respectively, we obtain the relations

$$p = 2xf'(u), \quad q = 2yf'(u)$$

where $f'(u) = df/du$, from which we obtain equation (2) by eliminating the arbitrary function $f(u)$.

Thus we see that the function z defined by each of the equations (1), (3), and (5) is, in some sense, a "solution" of the equation (2).

We shall now generalize this argument slightly. The relations (1) and (3) are both of the type

$$F(x, y, z, a, b) = 0 \quad (6)$$

where a and b denote arbitrary constants. If we differentiate this equation with respect to x , we obtain the relation

$$\frac{\partial F}{\partial x} + p \frac{\partial F}{\partial z} = 0, \quad \frac{\partial F}{\partial y} + q \frac{\partial F}{\partial z} = 0 \quad (7)$$

The set of equations (6) and (7) constitute three equations involving two arbitrary constants a and b , and, in the general case, it will be possible to eliminate a and b from these equations to obtain a relation of the kind

$$f(x, y, z, p, q) = 0 \quad (8)$$

showing that the system of surfaces (1) gives rise to a partial differential equation (8) of the first order.

The obvious generalization of the relation (5) is a relation between x , y , and z of the type

$$F(u, v) = 0 \quad (9)$$

where u and v are *known* functions of x , y , and z and F is an arbitrary function of u and v . If we differentiate equation (9) with respect to x and y , respectively, we obtain the equations

$$\frac{\partial F}{\partial u} \left\{ \frac{\partial u}{\partial x} + \frac{\partial u}{\partial z} p \right\} + \frac{\partial F}{\partial v} \left\{ \frac{\partial v}{\partial x} + \frac{\partial v}{\partial z} p \right\} = 0$$

$$\frac{\partial F}{\partial u} \left\{ \frac{\partial u}{\partial y} + \frac{\partial u}{\partial z} q \right\} + \frac{\partial F}{\partial v} \left\{ \frac{\partial v}{\partial y} + \frac{\partial v}{\partial z} q \right\} = 0$$

and if we now eliminate $\partial F/\partial u$ and $\partial F/\partial v$ from these equations, we obtain the equation

$$p \frac{\partial(u,v)}{\partial(y,z)} + q \frac{\partial(u,v)}{\partial(z,x)} = \frac{\partial(u,v)}{\partial(x,y)} \quad (10)$$

which is a partial differential equation of the type (8).

It should be observed, however, that the partial differential equation (10) is a *linear* equation; i.e., the powers of p and q are both unity, whereas equation (8) need not be linear. For example, the equation

$$(x - a)^2 + (y - b)^2 + z^2 = 1$$

which represents the set of all spheres of unit radius with center in the plane xOy , leads to the first-order nonlinear differential equation

$$z^2(1 + p^2 + q^2) = 1$$

PROBLEMS

1. Eliminate the constants a and b from the following equations:

(a) $z = (x + a)(y + b)$

(b) $2z = (ax + y)^2 + b$

(c) $ax^2 + by^2 + z^2 = 1$

2. Eliminate the arbitrary function f from the equations:

(a) $z = xy + f(x^2 + y^2)$

(b) $z = x + y + f(xy)$

(c) $z = f\left(\frac{xy}{z}\right)$

(d) $z = f(x - y)$

(e) $f(x^2 + y^2 + z^2, z^2 - 2xy) = 0$

3. Cauchy's Problem for First-order Equations

Though a complete discussion of existence theorems would be out of place in a work of this kind, it is important that, even at this elementary stage, the student should realize just what is meant by an existence

theorem. The business of an *existence* theorem is to establish conditions under which we can assert whether or not a given partial differential equation has a solution at all; the further step of proving that the solution, when it exists, is unique requires a *uniqueness* theorem. The conditions to be satisfied in the case of a first-order partial differential equation are conveniently crystallized in the classic *problem of Cauchy*, which in the case of two independent variables may be stated as follows:

Cauchy's Problem. If

(a) $x_0(\mu)$, $y_0(\mu)$, and $z_0(\mu)$ are functions which, together with their first derivatives, are continuous in the interval M defined by $\mu_1 < \mu < \mu_2$;

(b) And if $F(x, y, z, p, q)$ is a continuous function of x , y , z , p , and q in a certain region U of the $xyzpq$ space, then it is required to establish the existence of a function $\phi(x, y)$ with the following properties:

(1) $\phi(x, y)$ and its partial derivatives with respect to x and y are continuous functions of x and y in a region R of the xy space.

(2) For all values of x and y lying in R , the point $\{x, y, \phi(x, y), \phi_x(x, y), \phi_y(x, y)\}$ lies in U and

$$F[x, y, \phi(x, y), \phi_x(x, y), \phi_y(x, y)] = 0$$

(3) For all μ belonging to the interval M , the point $\{x_0(\mu), y_0(\mu)\}$ belongs to the region R , and

$$\phi\{x_0(\mu), y_0(\mu)\} = z_0$$

Stated geometrically, what we wish to prove is that there exists a surface $z = \phi(x, y)$ which passes through the curve Γ whose parametric equations are

$$x = x_0(\mu), \quad y = y_0(\mu), \quad z = z_0(\mu) \quad (1)$$

and at every point of which the direction $(p, q, -1)$ of the normal is such that

$$F(x, y, z, p, q) = 0 \quad (2)$$

We have given only one form of the problem of Cauchy. The problem can in fact be formulated in seven other ways which are equivalent to the formulation above.¹ The significant point is that the theorem cannot be proved with this degree of generality. To prove the existence of a solution of equation (2) passing through a curve with equations (1) it is necessary to make some further assumptions about the form of the function F and the nature of the curve Γ . There are, therefore, a whole class of existence theorems depending on the nature of these special

¹ For details the reader is referred to D. Bernstein, "Existence Theorems in Partial Differential Equations," *Annals of Mathematics Studies*, no. 23, (Princeton, Princeton, N.J., 1950), chap. II.

assumptions. We shall not discuss these existence theorems here but shall content ourselves with quoting one of them to show the nature of such a theorem. For the proof of it the reader should consult pages 32 to 36 of Bernstein's monograph cited above. The classic theorem in this field is that due to Sonia Kowalewski:

Theorem 1. *If $g(y)$ and all its derivatives are continuous for $|y - y_0| < \delta$, if x_0 is a given number and $z_0 = g(y_0)$, $q_0 = g'(y_0)$, and if $f(x, y, z, q)$ and all its partial derivatives are continuous in a region S defined by*

$$|x - x_0| < \delta, \quad |y - y_0| < \delta, \quad |q - q_0| < \delta$$

then there exists a unique function $\phi(x, y)$ such that:

(a) $\phi(x, y)$ and all its partial derivatives are continuous in a region R defined by $|x - x_0| < \delta_1$, $|y - y_0| < \delta_2$;

(b) For all (x, y) in R , $z = \phi(x, y)$ is a solution of the equation

$$\frac{\partial z}{\partial x} = f\left(x, y, z, \frac{\partial z}{\partial y}\right)$$

(c) For all values of y in the interval $|y - y_0| < \delta_1$, $\phi(x_0, y) = g(y)$.

Before passing on to the discussion of the solution of first-order partial differential equations, we shall say a word about different kinds of solutions. We saw in Sec. 2 that relations of the type

$$F(x, y, z, a, b) = 0 \tag{3}$$

led to partial differential equations of the first order. Any such relation which contains two arbitrary constants a and b and is a solution of a partial differential equation of the first order is said to be a *complete solution* or a *complete integral* of that equation. On the other hand any relation of the type

$$F(u, v) = 0 \tag{4}$$

involving an arbitrary function F connecting two known functions u and v of x , y , and z and providing a solution of a first-order partial differential equation is called a *general solution* or a *general integral* of that equation.

It is obvious that in some sense a general integral provides a much broader set of solutions of the partial differential equation in question than does a complete integral. We shall see later, however, that this is purely illusory in the sense that it is possible to derive a general integral of the equation once a complete integral is known (see Sec. 12).

4. Linear Equations of the First Order

We have already encountered linear equations of the first order in Sec. 2. They are partial differential equations of the form

$$Pp + Qq = R \tag{1}$$

where P , Q , and R are given functions of x , y , and z (which do not involve p or q), p denotes $\partial z/\partial x$, q denotes $\partial z/\partial y$, and we wish to find a relation between x , y , and z involving an arbitrary function. The first systematic theory of equations of this type was given by Lagrange. For that reason equation (1) is frequently referred to as *Lagrange's equation*. Its generalization to n independent variables is obviously the equation

$$X_1 p_1 - X_2 p_2 - \dots - X_n p_n = Y \quad (2)$$

where X_1, X_2, \dots, X_n , and Y are functions of n independent variables x_1, x_2, \dots, x_n and a dependent variable f ; p_i denotes $\partial f/\partial x_i$ ($i = 1, 2, \dots, n$). It should be observed that in this connection the term "linear" means that p and q (or, in the general case, p_1, p_2, \dots, p_n) appear to the first degree only but P, Q, R may be any functions of x, y , and z . This is in contrast to the situation in the theory of ordinary differential equations, where z must also appear linearly. For example, the equation

$$x \frac{\partial z}{\partial x} + y \frac{\partial z}{\partial y} = z^2 + x^2$$

is linear, whereas the equation

$$x \frac{dz}{dx} = z^2 + x^2$$

is not.

The method of solving linear equations of the form (1) is contained in:

Theorem 2. *The general solution of the linear partial differential equation*

$$Pp + Qq = R \quad (1)$$

is

$$F(u, v) = 0 \quad (3)$$

where F is an arbitrary function and $u(x, y, z) = c_1$ and $v(x, y, z) = c_2$ form a solution of the equations

$$\frac{dx}{P} = \frac{dy}{Q} = \frac{dz}{R} \quad (4)$$

We shall prove this theorem in two stages: (a) We shall show that all integral surfaces of the equation (1) are generated by the integral curves of the equations (4); (b) and then we shall prove that all surfaces generated by integral curves of the equations (4) are integral surfaces of the equation (1).

(a) If we are given that $z = f(x, y)$ is an integral surface of the partial differential equation (1), then the normal to this surface has direction cosines proportional to $(p, q, -1)$, and the differential equation (1) is no more than an analytical statement of the fact that this normal is perpendicular to the direction defined by the direction ratios (P, Q, R) . In

In other words, the direction (P, Q, R) is tangential to the integral surface $z = f(x, y)$.

Therefore, if we start from an arbitrary point M on the surface (cf. Fig. 14) and move in such a way that the direction of motion is always (P, Q, R) , we trace out an integral curve of the equations (4), and since $P, Q,$ and R are assumed to be unique, there will be only one such curve through M . Further, since (P, Q, R) is always tangential to the surface, we never leave the surface. In other words, this integral curve of the equations (4) lies completely on the surface.

We have therefore shown that through each point M of the surface there is one and only one integral curve of the equations (4) and that this curve lies entirely on the surface. That the integral surface of the equation (1) is generated by the integral curves of the equations (4).

5) Second, if we are given that the surface $z = f(x, y)$ is generated by integral curves of the equations (4), then we notice that its normal at a general point (x, y, z) which is in the direction $(\partial z / \partial x, \partial z / \partial y, -1)$ will be perpendicular to the direction (P, Q, R) of the curves generating the surface. Therefore

$$P \frac{\partial z}{\partial x} + Q \frac{\partial z}{\partial y} - R = 0$$

which is just another way of saying that $z = f(x, y)$ is an integral surface of equation (1).

To complete the proof of the theorem we have still to prove that any surface generated by the integral curves of the equations (4) has an equation of the form (3). Let any curve on the surface which is not a particular member of the system

$$u(x, y, z) = c_1, \quad v(x, y, z) = c_2 \tag{5}$$

satisfy the equations

$$\phi(x, y, z) = 0, \quad \psi(x, y, z) = 0 \tag{6}$$

Since the curve (5) is a generating curve of the surface, it will intersect the curve (6). The condition that it should do so will be obtained by eliminating $x, y,$ and z from the four equations (5) and (6). This will give a relation of the form

$$F(c_1, c_2) = 0 \tag{7}$$

between the constants c_1 and c_2 . The surface is therefore generated by curves (5) which obey the condition (7) and will therefore have an equation of the form

$$F(u, v) = 0 \tag{3}$$

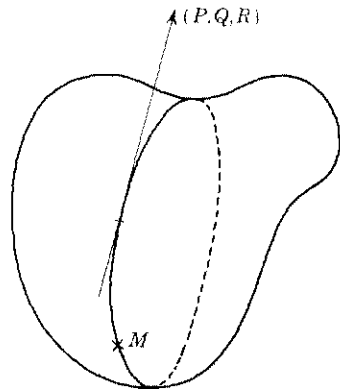

Figure 14

Conversely, any surface of the form (3) is generated by integral curves (5) of the equations (4), for it is that surface generated by those curves of the system (5) which satisfy the relation (7).

This completes the proof of the theorem.

We have used a geometrical method of proof to establish this theorem because it seems to show most clearly the relation between the two equations (1) and (4). The theorem can, however, be proved by purely analytical methods as we shall now show:

Alternative Proof. If the equations (5) satisfy the equations (4), then the equations

$$u_x dx + u_y dy + u_z dz = 0$$

and

$$\frac{dx}{P} = \frac{dy}{Q} = \frac{dz}{R}$$

must be compatible; i.e., we must have

$$Pu_x + Qu_y + Ru_z = 0$$

Similarly we must have

$$Pv_x + Qv_y + Rv_z = 0$$

Solving these equations for P , Q , and R , we have

$$\frac{P}{\partial(u,v)/\partial(y,z)} = \frac{Q}{\partial(u,v)/\partial(z,x)} = \frac{R}{\partial(u,v)/\partial(x,y)} \quad (8)$$

Now we showed in Sec. 2 that the relation

$$F(u,v) = 0$$

leads to the partial differential equation

$$p \frac{\partial(u,v)}{\partial(y,z)} + q \frac{\partial(u,v)}{\partial(z,x)} = \frac{\partial(u,v)}{\partial(x,y)} \quad (9)$$

Substituting from equations (8) into equation (9), we see that (3) is a solution of the equation (1) if u and v are given by equations (5).

We shall illustrate the method by considering a particular case:

Example 1. Find the general solution of the differential equation

$$x^2 \frac{\partial z}{\partial x} - y^2 \frac{\partial z}{\partial y} = (x + y)z$$

The integral surfaces of this equation are generated by the integral curves of the equations

$$\frac{dx}{x^2} = \frac{dy}{-y^2} = \frac{dz}{(x+y)z} \quad (10)$$

The first equation of this set has obviously the integral

$$x^{-1} - y^{-1} = c_1 \quad (11)$$

It follows immediately from the equations that

$$\frac{dx}{x^2 - y^2} = \frac{dy}{(x - y)^2} = \frac{dz}{(x - y)z}$$

which has the integral

$$\frac{x - y}{z} = c_2 \quad (12)$$

Combining the solutions (11) and (12), we see that the integral curves of the equations are given by equation (12) and the equation

$$\frac{xy}{z} = c_3 \quad (13)$$

so that the curves given by these equations generate the surface

$$F\left(\frac{xy}{z}, \frac{x - y}{z}\right) = 0 \quad (14)$$

where the function F is arbitrary.

It should be observed that this surface can be expressed by equations such as

$$z = xyf\left(\frac{x - y}{z}\right)$$

$$z = xyg\left(\frac{x - y}{xy}\right)$$

in which f and g denote arbitrary functions, which are apparently different from equation (14).

The theory we have developed for the case of two independent variables can, of course, be readily extended to the case of n independent variables, though in this case it is simpler to make use of an analytical method of proof than one which depends on the appreciation of geometrical ideas. The general theorem is:

Theorem 3. *If $u_i(x_1, x_2, \dots, x_n, z) = c_i$ ($i = 1, 2, \dots, n$) are independent solutions of the equations*

$$\frac{dx_1}{P_1} = \frac{dx_2}{P_2} = \dots = \frac{dx_n}{P_n} = \frac{dz}{R}$$

where the relation $\Phi(u_1, u_2, \dots, u_n) = 0$, in which the function Φ is arbitrary, is a general solution of the linear partial differential equation

$$P_1 \frac{\partial z}{\partial x_1} + P_2 \frac{\partial z}{\partial x_2} + \dots + P_n \frac{\partial z}{\partial x_n} = R$$

To prove this theorem we first of all note that if the solutions of the equations

$$\frac{dx_1}{P_1} = \frac{dx_2}{P_2} = \dots = \frac{dx_n}{P_n} = \frac{dz}{R} \quad (15)$$

$$u_i(x_1, x_2, \dots, x_n, z) = c_i \quad i = 1, 2, \dots, n \quad (16)$$

then the n equations

$$\sum_{j=1}^n \frac{\partial u_i}{\partial x_j} dx_j + \frac{\partial u_i}{\partial z} dz = 0 \quad i = 1, 2, \dots, n \quad (17)$$

must be compatible with the equations (15). In other words, we must have

$$\sum_{j=1}^n P_j \frac{\partial u_i}{\partial x_j} - R \frac{\partial u_i}{\partial z} = 0 \quad (18)$$

Solving the set of n equations (18) for P_i , we find that

$$\frac{P_i}{\frac{\partial(u_1, u_2, \dots, u_n)}{\partial(x_1, \dots, x_{i-1}, z, x_{i+1}, \dots, x_n)}} = \frac{R}{\frac{\partial(u_1, u_2, \dots, u_n)}{\partial(x_1, x_2, \dots, x_n)}} \quad i = 1, 2, \dots, n \quad (19)$$

where $\partial(u_1, u_2, \dots, u_n)/\partial(x_1, x_2, \dots, x_n)$ denotes the Jacobian

$$\begin{vmatrix} \frac{\partial u_1}{\partial x_1} & \frac{\partial u_1}{\partial x_2} & \dots & \frac{\partial u_1}{\partial x_n} \\ \frac{\partial u_2}{\partial x_1} & \frac{\partial u_2}{\partial x_2} & \dots & \frac{\partial u_2}{\partial x_n} \\ \cdot & \cdot & \cdot & \cdot \\ \cdot & \cdot & \cdot & \cdot \\ \frac{\partial u_n}{\partial x_1} & \frac{\partial u_n}{\partial x_2} & \dots & \frac{\partial u_n}{\partial x_n} \end{vmatrix}$$

Consider now the relation

$$\Phi(u_1, u_2, \dots, u_n) = 0 \quad (20)$$

Differentiating it with respect to x_i , we obtain the equation

$$\sum_{j=1}^n \left(\frac{\partial \Phi}{\partial u_j} \frac{\partial u_j}{\partial x_i} + \frac{\partial u_j}{\partial z} \frac{\partial z}{\partial x_i} \right) = 0$$

and there are n such equations, one for each value of i . Eliminating the n quantities $\partial \Phi / \partial u_1, \dots, \partial \Phi / \partial u_n$ from these equations, we obtain the relation

$$\frac{\partial(u_1, \dots, u_n)}{\partial(x_1, \dots, x_n)} - \sum_{j=1}^n \frac{\partial z}{\partial x_j} \frac{\partial(u_1, \dots, u_{j-1}, u_{j+1}, u_{j+1}, \dots, u_n)}{\partial(x_1, \dots, x_{j-1}, z, x_{j+1}, \dots, x_n)} = 0 \quad (21)$$

Substituting from equations (19) into the equation (21), we see that the function z defined by the relation (20) is a solution of the equation

$$P_1 \frac{\partial z}{\partial x_1} - P_2 \frac{\partial z}{\partial x_2} + \dots + P_n \frac{\partial z}{\partial x_n} = R \quad (22)$$

as we desired to show.

Example 2. If u is a function of x , y , and z which satisfies the partial differential equation

$$(y - z) \frac{\partial u}{\partial x} + (z - x) \frac{\partial u}{\partial y} + (x - y) \frac{\partial u}{\partial z} = 0$$

show that u contains x , y , and z only in combinations $x + y + z$ and $x^2 + y^2 + z^2$. In this case the auxiliary equations are

$$\frac{dx}{y - z} = \frac{dy}{z - x} = \frac{dz}{x - y} = \frac{du}{0}$$

and they are equivalent to the three relations

$$du = 0$$

$$dx + dy + dz = 0$$

$$x dx + y dy + z dz = 0$$

which show that the integrals are

$$u = c_1, \quad x + y + z = c_2, \quad x^2 + y^2 + z^2 = c_3$$

Hence the general solution is of the form

$$u = f(x + y + z, x^2 + y^2 + z^2)$$

as we were required to show.

It should be observed that there is a simple method of verifying a result of this kind once the answer is known. We transform the independent variables from x , y , and z to ξ , η , and ζ , where $\xi = x + y + z$, $\eta = x^2 + y^2 + z^2$, and ζ is any other combination of x , y , and z , say $y - z$. Then we have

$$\frac{\partial u}{\partial \xi} = \frac{\partial u}{\partial x} \frac{\partial x}{\partial \xi} + \frac{\partial u}{\partial y} \frac{\partial y}{\partial \xi} + \frac{\partial u}{\partial z} \frac{\partial z}{\partial \xi} \quad (23)$$

and it is readily shown that

$$\frac{\partial x}{\partial \xi} = -1, \quad \frac{\partial y}{\partial \xi} = \frac{x - z}{y - z}, \quad \frac{\partial z}{\partial \xi} = \frac{y - x}{y - z}$$

so that

$$(z - y) \frac{\partial u}{\partial \xi} = (y - z) \frac{\partial u}{\partial x} + (z - x) \frac{\partial u}{\partial y} + (x - y) \frac{\partial u}{\partial z}$$

If, therefore, the function u satisfies the given partial differential equation, we have $\partial u / \partial \xi = 0$, showing that $u = f(\xi, \eta)$, which is precisely what we found before.

PROBLEMS

Find the general integrals of the linear partial differential equations:

- $z(xp - yq) = y^2 - x^2$
- $px(z - 2y^2) = (z - qy)(z - y^2 - 2x^3)$
- $px(x + y) = qy(x + y) - (x - y)(2x + 2y + z)$
- $y^2p - xyq = x(z - 2y)$
- $(y + zx)p - (x + yz)q = x^2 - y^2$
- $x(x^2 + 3y^2)p - y(3x^2 + y^2)q = 2z(y^2 - x^2)$

5. Integral Surfaces Passing through a Given Curve

In the last section we considered a method of finding the general solution of a linear partial differential equation. We shall now indicate how such a general solution may be used to determine the integral surface which passes through a given curve. We shall suppose that we have found two solutions

$$u(x, y, z) = c_1, \quad v(x, y, z) = c_2 \quad (1)$$

of the auxiliary equations (4) of Sec. 4. Then, as we saw in that section, any solution of the corresponding linear equation is of the form

$$F(u, v) = 0 \quad (2)$$

arising from a relation

$$F(c_1, c_2) = 0 \quad (3)$$

between the constants c_1 and c_2 . The problem we have to consider is that of determining the function F in special circumstances.

If we wish to find the integral surface which passes through the curve c whose parametric equations are

$$x = x(t), \quad y = y(t), \quad z = z(t)$$

where t is a parameter, then the particular solution (1) must be such that

$$u\{x(t), y(t), z(t)\} = c_1, \quad v\{x(t), y(t), z(t)\} = c_2$$

We therefore have two equations from which we may eliminate the single variable t to obtain a relation of the type (3). The solution we are seeking is then given by equation (2).

Example 3. Find the integral surface of the linear partial differential equation

$$x(y^2 + z)p - y(x^2 + z)q + (x^2 - y^2)z$$

which contains the straight line $x + y = 0, z = 1$.

The auxiliary equations

$$\frac{dx}{x(y^2 + z)} = \frac{dy}{-y(x^2 + z)} = \frac{dz}{(x^2 - y^2)z}$$

have integrals

$$xyz = c_1, \quad x^2 + y^2 - 2z = c_2 \quad (4)$$

For the curve in question we have the freedom equations

$$x = t, \quad y = -t, \quad z = 1$$

Substituting these values in the pair of equations (4), we have the pair

$$-t^2 = c_1, \quad 2t^2 - 2 = c_2$$

and eliminating t from them, we find the relation

$$2c_1 + c_2 + 2 = 0$$

showing that the desired integral surface is

$$x^2 - y^2 + 2xyz - 2z + 2 = 0$$

PROBLEMS

1. Find the equation of the integral surface of the differential equation

$$2y(z-3)p - (2x-z)q - y(2x-3)$$

which passes through the circle $z=0, x^2+y^2=2x$.

2. Find the general integral of the partial differential equation

$$(2xy-1)p - (z-2x^2)q - 2(x-yz)$$

and also the particular integral which passes through the line $x=1, y=0$.

3. Find the integral surface of the equation

$$(x-y)y^2p - (y-x)x^2q + (x^2-y^2)z$$

through the curve $xz=y^3, y=0$.

4. Find the general solution of the equation

$$2x(y^2+z^2)p - y(2y^2+z^2)q - z^3$$

and deduce that

$$y(z^2-yz+z^2y) = x^2$$

is a solution.

5. Find the general integral of the equation

$$(x-y)p - (y-x-z)q + z$$

and the particular solution through the circle $z=1, x^2+y^2=1$.

6. Find the general solution of the differential equation

$$x(z-2a)p + (xz+2yz+2ay)q = z(z+a)$$

and also the integral surfaces which pass through the curves:

$$y=0, \quad z^2=4ax$$

$$x=0, \quad z^2+x(z+a)^2=0$$

Surfaces Orthogonal to a Given System of Surfaces

An interesting application of the theory of linear partial differential equations of the first order is to the determination of the systems of surfaces orthogonal to a given system of surfaces. Suppose we are given a one-parameter family of surfaces characterized by the equation

$$f(x, y, z) = c \quad (1)$$

and that we wish to find a system of surfaces which cut each of these surfaces at right angles (cf. Fig. 15).

The normal at the point (x, y, z) to the surface of the system (1) which passes through that point is the direction given by the direction ratios

$$(P, Q, R) = \left(\frac{\partial f}{\partial x}, \frac{\partial f}{\partial y}, \frac{\partial f}{\partial z} \right) \quad (2)$$

of the surface with equation

$$z = \phi(x, y) \quad (3)$$

cuts each surface of the given system orthogonally, then its normal at the point (x, y, z) which is in the direction

$$\left(\frac{\partial z}{\partial x}, \frac{\partial z}{\partial y}, -1 \right)$$

is perpendicular to the direction (P, Q, R) of the normal to the surface of the set (1) at that point. We therefore have the linear partial differential equation

$$P \frac{\partial z}{\partial x} + Q \frac{\partial z}{\partial y} - R = 0 \quad (4)$$

for the determination of the surfaces (3). Substituting from equations (2), we see that this equation is equivalent to

$$\frac{\partial f}{\partial x} \frac{\partial z}{\partial x} + \frac{\partial f}{\partial y} \frac{\partial z}{\partial y} = \frac{\partial f}{\partial z}$$

Conversely, any solution of the linear partial differential equation (4) is orthogonal to every surface of the system characterized by equation (1), for (4) simply states that the normal to any solution of (4) is perpendicular to the normal to that member of the system (1) which passes through the same point.

The linear equation (4) is therefore the general partial differential equation determining the surfaces orthogonal to members of the system (1); i.e., the surfaces orthogonal to the system (1) are the surfaces generated by the integral curves of the equations

$$\frac{dx}{\partial f / \partial x} = \frac{dy}{\partial f / \partial y} = \frac{dz}{\partial f / \partial z} \quad (5)$$

Example 4. Find the surface which intersects the surfaces of the system $z(x^2 + y^2) = c(3z - 1)$ orthogonally and which passes through the circle $x^2 + y^2 = 1, z = 1$. In this instance

$$f = \frac{z(x^2 + y^2)}{3z - 1}$$

so that the equations (5) take the form

$$\frac{dx}{z(3z - 1)} = \frac{dy}{z(3z - 1)} = \frac{dz}{(x^2 + y^2)}$$

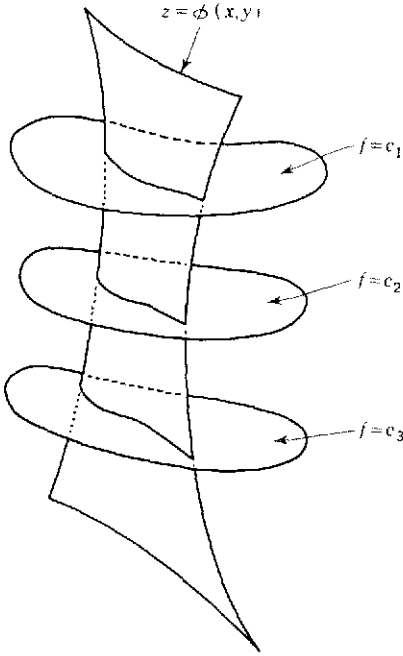

Figure 15

which have solutions

$$x - y = c_1, \quad x^2 + y^2 - 2z^3 - z^2 = c_2$$

Thus any surface which is orthogonal to the given surfaces has equation of the form

$$x^2 + y^2 - 2z^3 - z^2 = f(x - y)$$

For the particular surface passing through the circle $x^2 + y^2 = 1, z = 1$ we must take f to be the constant -2 . The required surface is therefore

$$x^2 + y^2 = 2z^3 + z^2 - 2$$

PROBLEMS

1. Find the surface which is orthogonal to the one-parameter system

$$z = cxy(x^2 + y^2)$$

and which passes through the hyperbola $x^2 - y^2 = a^2, z = 0$.

2. Find the equation of the system of surfaces which cut orthogonally the cones of the system $x^2 + y^2 - z^2 = cxy$.
3. Find the general equation of surfaces orthogonal to the family given by

$$(a) \quad x(x^2 + y^2 - z^2) = c_1y^2$$

showing that one such orthogonal set consists of the family of spheres given by

$$(b) \quad x^2 + y^2 - z^2 = c_2z$$

If a family exists, orthogonal to both (a) and (b), show that it must satisfy

$$2x(x^2 - z^2) dx + y(3x^2 + y^2 - z^2) dy + 2z(2x^2 + y^2) dz = 0$$

Show that such a family in fact exists, and find its equation.

7. Nonlinear Partial Differential Equations of the First Order

We turn now to the more difficult problem of finding the solutions of the partial differential equation

$$F(x, y, z, p, q) = 0 \quad (1)$$

in which the function F is not necessarily linear in p and q .

We saw in Sec. 2 that the partial differential equation of the two-parameter system

$$f(x, y, z, a, b) = 0 \quad (2)$$

was of this form. It will be shown a little later (Sec. 10) that the converse is also true; i.e., that any partial differential equation of the type (1) has solutions of the type (2). Any envelope of the system (2) touches at each of its points a member of the system.¹ It possesses therefore the same set of values (x, y, z, p, q) as the particular surface, so that it must also be a solution of the differential equation. In this

¹ The properties of one- and two-parameter systems of surfaces are outlined briefly in the Appendix.

way we are led to three classes of integrals of a partial differential equation of the type (1):

(a) Two-parameter systems of surfaces

$$f(x, y, z, a, b) = 0$$

Such an integral is called a *complete integral*.

(b) If we take any one-parameter subsystem

$$f(x, y, z, a, \phi(a)) = 0$$

of the system (2), and form its envelope, we obtain a solution of equation (1). When the function $\phi(a)$ which defines this subsystem is arbitrary, the solution obtained is called the *general integral* of (1) corresponding to the complete integral (2). When a definite function $\phi(a)$ is used, we obtain a particular case of the general integral.

(c) If the envelope of the two-parameter system (2) exists, it is also a solution of the equation (1); it is called the *singular integral* of the equation.

We can illustrate these three kinds of solution with reference to the partial differential equation

$$z^2(1 + p^2 + q^2) = 1 \quad (3)$$

We showed in Sec. 2 that

$$(x - a)^2 + (y - b)^2 + z^2 = 1 \quad (4)$$

was a solution of this equation with arbitrary a and b . Since it contains two arbitrary constants, the solution (4) is thus a *complete integral* of the equation (3).

Putting $b = a$ in equation (4), we obtain the one-parameter subsystem

$$(x - a)^2 + (y - a)^2 + z^2 = 1$$

whose envelope is obtained by eliminating a between this equation and

$$x + y - 2a = 0$$

so that it has equation

$$(x - y)^2 + 2z^2 = 2 \quad (5)$$

Differentiating both sides of this equation with respect to x and y , respectively, we obtain the relations

$$2zp = y - x, \quad 2zq = x - y$$

from which it follows immediately that (5) is an integral surface of the equation (3). It is a solution of type (b); i.e., it is a *general integral* of the equation (3).

The envelope of the two-parameter system (3) is obtained by eliminating a and b from equation (4) and the two equations

$$x - a = 0 \quad y - b = 0$$

er, the envelope consists of the pair of planes $z = \pm 1$. It is readily verified that these planes are integral surfaces of the equation (3); since they are of type (c) they constitute the *singular integral* of the equation.

It should be noted that, theoretically, it is always possible to obtain different complete integrals which are not equivalent to each other, i.e., which cannot be obtained from one another merely by a change in the choice of arbitrary constants. When, however, one complete integral has been obtained, every other solution, including every other complete integral, appears among the solutions of type (b) and (c) corresponding to the complete integral we have found.

To illustrate both these points we note that

$$(y - mx - c)^2 = (1 + m^2)(1 - z^2) \quad (6)$$

is a complete integral of equation (3), since it contains two arbitrary constants m and c , and it cannot be derived from the complete integral (4) by a simple change in the values of a and b . It can be readily shown, however, that the solution (6) is the envelope of the one-parameter subsystem of (4) obtained by taking $b = ma + c$.

PROBLEMS

1. Verify that $z = ax + by + a - b - ab$ is a complete integral of the partial differential equation

$$z = px + qy + p - q - pq$$

where a and b are arbitrary constants. Show that the envelope of all planes corresponding to complete integrals provides a singular solution of the differential equation, and determine a general solution by finding the envelope of those planes that pass through the origin.

2. Verify that the equations

$$a) \quad z = \sqrt{2x + a} + \sqrt{2y - b}$$

$$b) \quad z^2 + \mu = 2(1 + \lambda^{-1})(x + \lambda y)$$

are both complete integrals of the partial differential equation

$$z = \frac{1}{p} - \frac{1}{q}$$

Show, further, that the complete integral (b) is the envelope of the one-parameter subsystem obtained by taking

$$b = -\frac{a}{\lambda} - \frac{\mu}{1 - \lambda}$$

in the solution (a).

Cauchy's Method of Characteristics

We shall now consider methods of solving the nonlinear partial differential equation

$$F\left(x, y, z, \frac{\partial z}{\partial x}, \frac{\partial z}{\partial y}\right) = 0 \quad (1)$$

In this section we shall consider a method, due to Cauchy, which is based largely on geometrical ideas.

The plane passing through the point $P(x_0, y_0, z_0)$ with its normal parallel to the direction n defined by the direction ratios $(p_0, q_0, -1)$ is uniquely specified by the set of numbers $D(x_0, y_0, z_0, p_0, q_0)$. Conversely any such set of five real numbers defines a plane in three-dimensional space. For this reason a set of five numbers $D(x, y, z, p, q)$ is called a *plane element* of the space. In particular a plane element $(x_0, y_0, z_0, p_0, q_0)$ whose components satisfy an equation

$$F(x, y, z, p, q) = 0 \quad (2)$$

is called an *integral element* of the equation (2) at the point (x_0, y_0, z_0) .

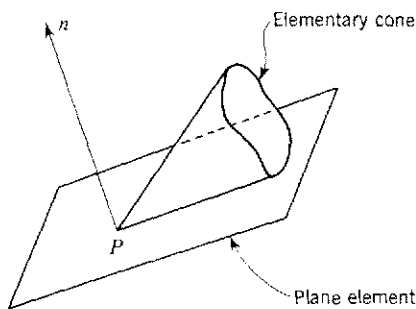

Figure 16

It is theoretically possible to solve an equation of the type (2) to obtain an expression

$$q = G(x, y, z, p) \quad (3)$$

from which to calculate q when x , y , z , and p are known. Keeping x_0 , y_0 , and z_0 fixed and varying p , we obtain a set of plane elements $\{x_0, y_0, z_0, p, G(x_0, y_0, z_0, p)\}$, which depend on the single parameter p . As p varies, we obtain a set of plane elements all of which

pass through the point P and which therefore envelop a cone with vertex P ; the cone so generated is called the *elementary cone* of equation (2) at the point P (cf. Fig. 16).

Consider now a surface S whose equation is

$$z = g(x, y) \quad (4)$$

If the function $g(x, y)$ and its first partial derivatives $g_x(x, y)$, $g_y(x, y)$ are continuous in a certain region R of the xy plane, then the tangent plane at each point of S determines a plane element of the type

$$\{x_0, y_0, g(x_0, y_0), g_x(x_0, y_0), g_y(x_0, y_0)\} \quad (5)$$

which we shall call the *tangent element* of the surface S at the point $\{x_0, y_0, g(x_0, y_0)\}$.

It is obvious on geometrical grounds that:

Theorem 4. *A necessary and sufficient condition that a surface be an integral surface of a partial differential equation is that at each point its tangent element should touch the elementary cone of the equation.*

A curve C with parametric equations

$$x = x(t), \quad y = y(t), \quad z = z(t) \quad (6)$$

lies on the surface (4) if

$$z(t) = g\{x(t), y(t)\}$$

for all values of t in the appropriate interval I . If P_0 is a point on this curve determined by the parameters t_0 , then the direction ratios of the tangent line P_0P_1 (cf. Fig. 17) are $\{x'(t_0), y'(t_0), z'(t_0)\}$, where $x'(t_0)$ denotes the value of dx/dt when $t = t_0$, etc. This direction will be perpendicular to the direction $(p_0, q_0, -1)$ if

$$z'(t_0) - p_0x_0'(t_0) - q_0y_0'(t_0)$$

For this reason we say that any set

$$\{x(t), y(t), z(t), p(t), q(t)\} \tag{7}$$

of five real functions satisfying the condition

$$z'(t) = p(t)x'(t) + q(t)y'(t) \tag{8}$$

defines a strip at the point (x, y, z) of the curve C . If such a strip is also an integral element of equation (2), we say that it is an *integral strip* of equation (2); i.e., the set of functions (7) is an integral strip of equation (2) provided they satisfy condition (8) and the further condition

$$F\{x(t), y(t), z(t), p(t), q(t)\} = 0 \tag{9}$$

for all t in I .

If at each point the curve (6) touches a generator of the elementary cone, we say that the corresponding strip is a *characteristic strip*. We shall now derive the equations determining a characteristic strip. The point $(x + dx, y + dy, z + dz)$ lies in the tangent plane to the elementary cone at P if

$$dz = p dx + q dy \tag{10}$$

where p, q satisfy the relation (2). Differentiating (10) with respect to x we obtain

$$0 = dx + \frac{dq}{dp} dy \tag{11}$$

where, from (2),

$$\frac{\partial F}{\partial p} + \frac{\partial F}{\partial q} \frac{dq}{dp} = 0 \tag{12}$$

Solving the equations (10), (11), and (12) for the ratios of dy, dz to dx , we obtain

$$\frac{dx}{F_p} = \frac{dy}{F_q} = \frac{dz}{pF_p + qF_q} \tag{13}$$

that along a characteristic strip $x'(t), y'(t), z'(t)$ must be proportional

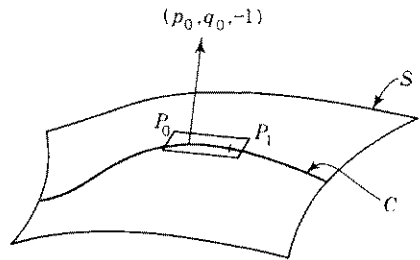

Figure 17

to F_p , F_q , $pF_p + qF_q$, respectively. If we choose the parameter t in such a way that

$$x'(t) = F_p, \quad y'(t) = F_q \quad (14)$$

then

$$z'(t) = pF_p + qF_q \quad (15)$$

Along a characteristic strip p is a function of t so that

$$\begin{aligned} p'(t) &= \frac{\partial p}{\partial x} x'(t) + \frac{\partial p}{\partial y} y'(t) \\ &= \frac{\partial p}{\partial x} \frac{\partial F}{\partial p} + \frac{\partial p}{\partial y} \frac{\partial F}{\partial q} \\ &= \frac{\partial p}{\partial x} \frac{\partial F}{\partial p} + \frac{\partial q}{\partial x} \frac{\partial F}{\partial q} \end{aligned}$$

since $\partial p / \partial y \equiv \partial q / \partial x$. Differentiating equation (2) with respect to x , we find that

$$\frac{\partial F}{\partial x} + \frac{\partial F}{\partial z} p + \frac{\partial F}{\partial p} \frac{\partial p}{\partial x} + \frac{\partial F}{\partial q} \frac{\partial q}{\partial x} = 0$$

so that on a characteristic strip

$$p'(t) = -(F_x + pF_z) \quad (16)$$

and it can be shown similarly that

$$q'(t) = -(F_y + qF_z) \quad (17)$$

Collecting equations (14) to (17) together, we see that we have the following system of five ordinary differential equations for the determination of the characteristic strip

$$\begin{aligned} x'(t) &= F_p, & y'(t) &= F_q, & z'(t) &= pF_p + qF_q \\ p'(t) &= -F_x - pF_z, & q'(t) &= -F_y - qF_z \end{aligned} \quad (18)$$

These equations are known as the *characteristic equations* of the differential equation (2). These equations are of the same type as those considered in Sec. 2 of Chap. 1, so that it follows, from a simple extension of Theorem 1 of that section, that, if the functions which appear in equations (18) satisfy a Lipschitz condition, there is a unique solution of the equations for each prescribed set of initial values of the variables. Therefore the characteristic strip is determined uniquely by any initial element $(x_0, y_0, z_0, p_0, q_0)$ and any initial value t_0 of t .

The main theorem about characteristic strips is:

Theorem 5. *Along every characteristic strip of the equation $F(x, y, z, p, q) = 0$ the function $F(x, y, z, p, q)$ is a constant.*

The proof is a matter simply of calculation. Along a characteristic strip we have

$$\begin{aligned} \frac{d}{dt} F\{x(t), y(t), z(t), p(t), q(t)\} \\ = F_x x' + F_y y' + F_z z' + F_p p' + F_q q' \\ = F_x F_v + F_y F_a - F_z (pF_v - qF_a) - F_v (F_x + pF_z) - F_q (F_y + qF_z) \\ = 0 \end{aligned}$$

so that $F(x, y, z, p, q) = k$, a constant along the strip.

As a corollary we have immediately:

Theorem 6. *If a characteristic strip contains at least one integral element of $F(x, y, z, p, q) = 0$ it is an integral strip of the equation $F(x, y, z, z_x, z_y) = 0$.*

We are now in a position to solve Cauchy's problem. Suppose we wish to find the solution of the partial differential equation (I) which passes through a curve Γ whose freedom equations are

$$x = \theta(v), \quad y = \phi(v), \quad z = \chi(v) \tag{19}$$

then in the solution

$$x = x(p_0, q_0, x_0, y_0, z_0, t_0, t), \text{ etc.} \tag{20}$$

of the characteristic equations (18) we may take

$$x_0 = \theta(v), \quad y_0 = \phi(v), \quad z_0 = \chi(v)$$

as the initial values of x, y, z . The corresponding initial values of p_0, q_0 are determined by the relations

$$\chi'(v) = p_0 \theta'(v) + q_0 \phi'(v)$$

$$F\{\theta(v), \phi(v), \chi(v), p_0, q_0\} = 0$$

we substitute these values of x_0, y_0, z_0, p_0, q_0 and the appropriate value of t_0 in equation (20), we find that x, y, z can be expressed in terms of the two parameters t, v , to give

$$x = X_1(v, t), \quad y = Y_1(v, t), \quad z = Z_1(v, t) \tag{21}$$

Eliminating v, t from these three equations, we get a relation

$$\psi(x, y, z) = 0$$

which is the equation of the integral surface of equation (1) through the curve Γ . We shall illustrate this procedure by an example.

Example 5. *Find the solution of the equation*

$$z = \frac{1}{2}(p^2 - q^2) + (p - x)(q - y)$$

passes through the x -axis.

It is readily shown that the initial values are

$$x_0 = v, \quad y_0 = 0, \quad z_0 = 0, \quad p_0 = 0, \quad q_0 = 2v, \quad t_0 = 0$$

The characteristic equations of this partial differential equation are

$$\begin{aligned} \frac{dx}{dt} &= p + q - y, & \frac{dy}{dt} &= p + q - x, & \frac{dz}{dt} &= p(p + q - y) + q(p - q - x) \\ \frac{dp}{dt} &= p + q - y, & \frac{dq}{dt} &= p + q - x \end{aligned}$$

from which it follows immediately that

$$x = v + p, \quad y = q - 2v$$

Also it is readily shown that

$$\frac{d}{dt}(p + q - x) = p + q - x, \quad \frac{d}{dt}(p + q - y) = p + q - y$$

giving

$$p + q - x = ve^t, \quad p + q - y = 2ve^t$$

Hence we have

$$x = v(2e^t - 1), \quad y = v(e^t - 1), \quad p = 2v(e^t - 1), \quad q = v(e^t + 1) \quad (22)$$

Substituting in the third of the characteristic equations, we have

$$\frac{dz}{dt} = 5v^2e^{2t} - 3v^2e^t$$

with solution

$$z = \frac{5}{2}v^2(e^{2t} - 1) - 3v^2(e^t - 1) \quad (23)$$

Now from the first pair of equations (22) we have

$$e^t = \frac{y - x}{2y - x}, \quad v = x - 2y$$

so that substituting in (23), we obtain the solution

$$z = \frac{1}{2}y(4x - 3y)$$

PROBLEMS

1. Find the characteristics of the equation $pq = z$, and determine the integral surface which passes through the parabola $x = 0, y^2 = z$.
2. Write down, and integrate completely, the equations for the characteristics of

$$(1 + q^2)z = px$$

expressing x, y, z , and p in terms of ϕ , where $q = \tan \phi$, and determine the integral surface which passes through the parabola $x^2 = 2z, y = 0$.

3. Determine the characteristics of the equation $z = p^2 - q^2$, and find the integral surface which passes through the parabola $4z + x^2 = 0, y = 0$.
4. Integrate the equations for the characteristics of the equation

$$p^2 + q^2 = 4z$$

expressing x, y, z , and p in terms of q , and then find the solutions of the equation which reduce to $z = x^2 + 1$ when $y = 0$.

9. Compatible Systems of First-order Equations

We shall next consider the condition to be satisfied in order that every solution of the first-order partial differential equation

$$f(x, y, z, p, q) = 0 \tag{1}$$

is also a solution of the equation

$$g(x, y, z, p, q) = 0 \tag{2}$$

When such a situation arises, the equations are said to be *compatible*.

If

$$J = \frac{\partial(f, g)}{\partial(p, q)} \neq 0 \tag{3}$$

we can solve equations (1) and (2) to obtain the explicit expressions

$$p = \phi(x, y, z), \quad q = \psi(x, y, z) \tag{4}$$

for p and q . The condition that the pair of equations (1) and (2) should be compatible reduces then to the condition that the system of equations (4) should be completely integrable, i.e., that the equation

$$\phi dx + \psi dy - dz = 0$$

should be integrable. From Theorem 5 of Chap. I we see that the condition that this equation is integrable is

$$\phi(-\psi_z) + \psi(\phi_z) - (\psi_x - \phi_y) = 0$$

which is equivalent to

$$\psi_x + \phi\psi_z = \phi_y + \psi\phi_z \tag{5}$$

Substituting from equations (4) into equation (1) and differentiating with regard to x and z , respectively, we obtain the equations

$$f_x + f_p\phi_x + f_q\psi_x = 0$$

$$f_z + f_p\phi_z + f_q\psi_z = 0$$

from which it is readily deduced that

$$f_x + \phi f_z + f_p(\phi_x + \phi\phi_z) + f_q(\psi_x + \phi\psi_z) = 0$$

Similarly we may deduce from equation (2) that

$$g_x + \phi g_z + g_p(\phi_x + \phi\phi_z) + g_q(\psi_x + \phi\psi_z) = 0$$

Solving these equations, we find that

$$\psi_x + \phi\psi_z = \frac{1}{J} \left\{ \frac{\partial(f, g)}{\partial(x, p)} + \phi \frac{\partial(f, g)}{\partial(z, p)} \right\} \tag{6}$$

where J is defined as equation (3).

If we had differentiated the given pair of equations with respect to y and z , we should have obtained

$$\phi_y + \psi\phi_z = -\frac{1}{J} \left\{ \frac{\partial(f,g)}{\partial(y,q)} + \psi \frac{\partial(f,g)}{\partial(z,q)} \right\} \quad (7)$$

so that, substituting from equations (6) and (7) into equation (5) and replacing ϕ , ψ by p , q , respectively, we see that the condition that the two conditions should be compatible is that

$$[f,g] = 0 \quad (8)$$

$$\text{where} \quad [f,g] \equiv \frac{\partial(f,g)}{\partial(x,p)} + p \frac{\partial(f,g)}{\partial(z,p)} + \frac{\partial(f,g)}{\partial(y,q)} + q \frac{\partial(f,g)}{\partial(z,q)} \quad (9)$$

Example 6. Show that the equations

$$xp = yq, \quad z(xp + yq) = 2xy$$

are compatible and solve them.

In this example we may take $f = xp - yq$, $g = z(xp + yq) - 2xy$ so that

$$\frac{\partial(f,g)}{\partial(x,p)} = 2xy, \quad \frac{\partial(f,g)}{\partial(z,p)} = -x^2p, \quad \frac{\partial(f,g)}{\partial(y,q)} = -2xy, \quad \frac{\partial(f,g)}{\partial(z,q)} = xyp$$

from which it follows that

$$[f,g] = xp(yq - xp) = 0$$

since $xp = yp$. The equations are therefore compatible.

It is readily shown that $p = y/z$, $q = x/z$, so that we have to solve

$$z dz = -y dx + x dy$$

which has solution

$$z^2 = c_1 + 2xy$$

where c_1 is a constant.

PROBLEMS

1. Show that the equations

$$xp - yq = x, \quad x^2p + q = xz$$

are compatible and find their solution.

2. Show that the equation $z = px + qy$ is compatible with any equation $f(x,y,z,p,q) = 0$ that is homogeneous in x , y , and z .

Solve completely the simultaneous equations

$$z = px + qy, \quad 2xy(p^2 + q^2) = z(y^2 + xq)$$

3. Show that the equations $f(x,y,p,q) = 0$, $g(x,y,p,q) = 0$ are compatible if

$$\frac{\partial(f,g)}{\partial(x,p)} + \frac{\partial(f,g)}{\partial(y,q)} = 0$$

Verify that the equations $p = P(x,y)$, $q = Q(x,y)$ are compatible if

$$\frac{\partial P}{\partial y} = \frac{\partial Q}{\partial x}$$

4. If $u_1 = \partial u / \partial x$, $u_2 = \partial u / \partial y$, $u_3 = \partial u / \partial z$, show that the equations

$$f(x, y, z, u_1, u_2, u_3) = 0, \quad g(x, y, z, u_1, u_2, u_3) = 0$$

are compatible if

$$\frac{\partial(f, g)}{\partial(x, u_1)} - \frac{\partial(f, g)}{\partial(y, u_2)} + \frac{\partial(f, g)}{\partial(z, u_3)} = 0$$

10. Charpit's Method

A method of solving the partial differential equation

$$f(x, y, z, p, q) = 0 \quad (1)$$

due to Charpit, is based on the considerations of the last section. The fundamental idea in Charpit's method is the introduction of a second partial differential equation of the first order

$$g(x, y, z, p, q, a) = 0 \quad (2)$$

which contains an arbitrary constant a and which is such that:

(a) Equations (1) and (2) can be solved to give

$$p = p(x, y, z, a), \quad q = q(x, y, z, a)$$

(b) The equation

$$dz = p(x, y, z, a) dx + q(x, y, z, a) dy \quad (3)$$

is integrable.

When such a function g has been found, the solution of equation (3)

$$F(x, y, z, a, b) = 0 \quad (4)$$

containing two arbitrary constants a, b will be a solution of equation (1). From the considerations of Sec. 7 it will be seen that equation (4) is a complete integral of equation (1).

The main problem then is the determination of the second equation (2), but this has already been solved in the last section, since we need only seek an equation $g = 0$ compatible with the given equation $f = 0$. The conditions for this are symbolized in equations (3) and (8) of the last section. Expanding the latter equation, we see that it is equivalent to the linear partial differential equation

$$\begin{aligned} f_x \frac{\partial g}{\partial x} + f_y \frac{\partial g}{\partial y} + (pf_x + qf_y) \frac{\partial g}{\partial z} \\ - (f_x + pf_z) \frac{\partial g}{\partial p} - (f_y + qf_z) \frac{\partial g}{\partial q} = 0 \end{aligned} \quad (5)$$

for the determination of g . Our problem then is to find a solution of this equation, as simple as possible, involving an arbitrary constant a , and this we do by finding an integral of the subsidiary equations

$$\frac{dx}{f_x} = \frac{dy}{f_y} = \frac{dz}{pf_x + qf_y} = \frac{dp}{-(f_x + pf_z)} = \frac{dq}{-(f_y + qf_z)} \quad (6)$$

in accordance with Theorem 3. These equations, which are known as Charpit's equations, are equivalent to the characteristic equations (18) of Sec. 8.

Once an integral $g(x, y, z, p, q, a)$ of this kind has been found, the problem reduces to solving for p , q , and then integrating equation (3) by the methods of Sec. 6 of Chap. 1. It should be noted that not all of Charpit's equations (6) need be used, but that p or q must occur in the solution obtained.

Example 7. Find a complete integral of the equation

$$p^2x - q^2y = z \quad (7)$$

The auxiliary equations are

$$\frac{dx}{2px} = \frac{dy}{-2qy} = \frac{dz}{2(p^2x - q^2y)} = \frac{dp}{p - p^2} = \frac{dq}{q + q^2}$$

from which it follows that

$$\frac{p^2 dx}{p^2x} = \frac{2px dp}{p^2x} = \frac{q^2 dy}{q^2y} = \frac{2qy dq}{q^2y}$$

and hence that

$$p^2x = aq^2y \quad (8)$$

where a is a constant. Solving equations (7) and (8) for p , q , we have

$$p = \left(\frac{az}{(1 - a)x} \right)^{\frac{1}{2}}, \quad q = \left(\frac{z}{(1 + a)y} \right)^{\frac{1}{2}}$$

so that equation (3) becomes in this case

$$\left(\frac{1 + a}{z} \right)^{\frac{1}{2}} dz = \left(\frac{a}{x} \right)^{\frac{1}{2}} dx - \left(\frac{1}{y} \right)^{\frac{1}{2}} dy$$

with solution

$$\{(1 + a)z\}^{\frac{1}{2}} = (ax)^{\frac{1}{2}} - y^{\frac{1}{2}} + b$$

which is therefore a complete integral of (7).

PROBLEMS

Find the complete integrals of the equations:

1. $(p^2 + q^2)y = qz$
2. $p = (z + qy)^2$
3. $z^2 = pqxy$
4. $xp + 3yq = 2(z - x^2q^2)$
5. $px^3 - 4q^2x^2 + 6x^2z - 2 = 0$
6. $2(y + zq) = q(xp + yq)$
7. $2(z + xp + yq) = yp^2$

11. Special Types of First-order Equations

In this section we shall consider some special types of first-order partial differential equations whose solutions may be obtained easily by Charpit's method.

(a) *Equations Involving Only p and q .* For equations of the type

$$f(p, q) = 0 \quad (1)$$

Charpit's equations reduce to

$$\frac{dx}{f_p} = \frac{dy}{f_q} = \frac{dz}{pf_p + qf_q} = \frac{dp}{0} = \frac{dq}{0}$$

An obvious solution of these equations is

$$p = a \quad (2)$$

the corresponding value of q being obtained from (1) in the form

$$f(a, q) = 0 \quad (3)$$

so that

$$q = Q(a)$$

a constant. The solution of the equation is then

$$z = ax + Q(a)y + b \quad (4)$$

where b is a constant.

We have chosen the equation $dp = 0$ to provide our second equation. In some problems the amount of computation involved is considerably reduced if we take instead $dq = 0$, leading to $q = a$.

Example 8. Find a complete integral of the equation $pq = 1$.

In this case $Q(a) = 1/a$, so that we see, from equation (4), that a complete integral is

$$z = ax + \frac{y}{a} + b$$

which is equivalent to

$$a^2x + y = az + c$$

where a, c are arbitrary constants.

(b) *Equations Not Involving the Independent Variables.* If the partial differential equation is of the type

$$f(z, p, q) = 0 \quad (5)$$

Charpit's equations take the forms

$$\frac{dx}{f_p} = \frac{dy}{f_q} = \frac{dz}{pf_p + qf_q} = \frac{dp}{-pf_z} = \frac{dq}{-qf_z}$$

the last of which leads to the relation

$$p = aq \quad (6)$$

Solving (5) and (6), we obtain expressions for p, q from which a complete integral follows immediately.

Example 9. Find a complete integral of the equation $p^2z^2 + q^2 = 1$.
Putting $p = aq$, we find that

$$q^2(1 + a^2z^2) = 1, \quad q = (1 + a^2z^2)^{-1/2}, \quad p = a(1 + a^2z^2)^{-1/2}$$

Hence $(1 + a^2z^2)^{1/2} dz = a dx + dy$

which leads to the complete integral

$$az(1 + a^2z^2)^{1/2} = \log [az + (1 + a^2z^2)^{1/2}] + 2a(ax + y + b)$$

(c) *Separable Equations.* We say that a first-order partial differential is *separable* if it can be written in the form

$$f(x,p) = g(y,q) \quad (7)$$

For such an equation Charpit's equations become

$$\frac{dx}{f_p} = \frac{dy}{-g_q} = \frac{dz}{pf_p - qg_q} = \frac{dp}{-f_x} = \frac{dq}{-g_y}$$

so that we have an ordinary differential equation

$$\frac{dp}{dx} + \frac{f_x}{f_p} = 0$$

in x and p which may be solved to give p as a function of x and an arbitrary constant a . Writing this equation in the form $f_p dp + f_x dx = 0$, we see that its solution is $f(x,p) = a$. Hence we determine p, q from the relations-

$$f(x,p) = a, \quad g(y,q) = a \quad (8)$$

and then proceed as in the general theory.

Example 10. Find a complete integral of the equation $p^2y(1 - x^2) = qx^2$.
We first observe that we can write the equation in the form

$$\frac{p^2(1 - x^2)}{x^2} = \frac{q}{y}$$

so that $p = \frac{ax}{\sqrt{1 - x^2}}, \quad q = a^2y$

and hence a complete integral is

$$z = a\sqrt{1 - x^2} - \frac{1}{2}a^2y^2 + b$$

where a and b are constants.

(d) *Clairaut Equations.* A first-order partial differential equation is said to be of Clairaut type if it can be written in the form

$$z = px + qy + f(p,q) \quad (9)$$

The corresponding Charpit equations are

$$\frac{dx}{x + f_p} = \frac{dy}{y + f_q} = \frac{dz}{px + qy + pf_p + qf_q} = \frac{dp}{0} = \frac{dq}{0}$$

so that we may take $p = a$, $q = b$. If we substitute these values in (9), we get the complete integral

$$z = ax + by + f(a, b) \quad (10)$$

as is readily verified by direct differentiation.

Example 11. Find a complete integral of the equation

$$(p + q)(z - xp - yq) = 1$$

Writing this equation in the form

$$z = xp + yq + \frac{1}{p + q}$$

we see that a complete integral is

$$z = ax + by + \frac{1}{a + b}$$

PROBLEMS

Find complete integrals of the equations:

1. $p + q = pq$
2. $z = p^2 + q^2$
3. $zpq = p + q$
4. $p^2q(x^2 + y^2) = p^2 + q$
5. $p^2q^2 + x^2y^2 = x^2q^2(x^2 + y^2)$
6. $pqz = p^2(xq + p^2) + q^2(yq + q^2)$

12. Solutions Satisfying Given Conditions

In this section we shall consider the determination of surfaces which satisfy the partial differential equation

$$F(x, y, z, p, q) = 0 \quad (1)$$

and which satisfy some other condition such as passing through a given curve or circumscribing a given surface. We shall also consider how to derive one complete integral from another.

First of all, we shall discuss how to determine the solution of (1) which passes through a given curve C which has parametric equations

$$x = x(t), \quad y = y(t), \quad z = z(t) \quad (2)$$

t being a parameter. If there is an integral surface of the equation (1) through the curve C , then it is:

(a) A particular case of the complete integral

$$f(x, y, z, a, b) = 0 \quad (3)$$

obtained by giving a or b particular values; or

(b) A particular case of the general integral corresponding to (3), i.e., the envelope of a one-parameter subsystem of (3); or

(c) The envelope of the two-parameter system (3).

It seems unlikely that the solution would fall into either (a) or (c) so we consider the case (b), which is the one which occurs most frequently. We suppose, therefore, that a surface, E say, of type (b) exists and passes through the curve C . At every one of its points this envelope E is touched by some member of the subsystem. In particular at each point P of the curve C we may suppose it to be touched by a member, S_p , say, of the subsystem, and since S_p touches E at P , it also touches C at the same point. In other words, E is the envelope of a one-parameter subsystem of (3) each of whose members touches the curve C , provided that such a subsystem exists. To determine E , then, we must consider the subsystem made up of those members of the family (3) which touch the curve C . The points of intersection of the surface (3) and the curve C are determined in terms of the parameter t by the equation

$$f\{x(t), y(t), z(t), a, b\} = 0 \quad (4)$$

and the condition that the curve C should touch the surface (3) is that the equation (4) must have two equal roots or, what is the same thing, that equation (4) and the equation

$$\frac{\partial}{\partial t} f\{x(t), y(t), z(t), a, b\} = 0 \quad (5)$$

should have a common root. The condition for this to be so is the eliminant of t from (4) and (5),

$$\psi(a, b) = 0 \quad (6)$$

which is a relation between a and b alone. The equation (6) may be factorized into a set of alternative equations

$$b = \phi_1(a), \quad b = \phi_2(a), \quad \dots \quad (7)$$

each of which defines a subsystem of one parameter. The envelope of each of these one-parameter subsystems is a solution of the problem.

Example 12. Find a complete integral of the partial differential equation

$$(p^2 + q^2)x = pz$$

and deduce the solution which passes through the curve $x = 0, z^2 = 4y$.

It may readily be shown that

$$z^2 = a^2x^2 + (ay + b)^2 \quad (8)$$

is a complete integral, and it is left to the reader to do so.

The parametric equations of the given curve are

$$x = 0, \quad y = t^2, \quad z = 2t \quad (9)$$

The intersections of (8) and (9) are therefore determined by

$$4t^2 - (at^2 + b)^2$$

i.e., by
$$a^2t^4 - (2ab + 4)t^2 + b^2 = 0$$

and this equation has equal roots if

$$(ab - 2)^2 = a^2b^2$$

i.e., if
$$ab = 1$$

The appropriate one-parameter subsystem is therefore

$$z^2 = a^2x^2 - \left(ay + \frac{1}{a} \right)^2$$

i.e.,
$$a^4(x^2 + y^2) - a^2(2y - z^2) + 1 = 0$$

and this has for its envelope the surface

$$(2y - z^2)^2 = 4(x^2 + y^2) \quad (10)$$

The function z defined by equation (10) is the solution of the problem.

The problem of deriving one complete integral from another may be treated in a very similar way. Suppose we know that

$$f(x, y, z, a, b) = 0 \quad (11)$$

is a complete integral and wish to show that another relation

$$g(x, y, z, h, k) = 0 \quad (12)$$

involving two arbitrary constants h, k is also a complete integral. We choose on the surface (12) a curve Γ in whose equations the constants h, k appear as independent parameters and then find the envelope of the one-parameter subsystem of (11) touching the curve Γ . Since this solution contains two arbitrary constants, it is a complete integral.

Example 13. Show that the equation

$$xpq + yq^2 = 1$$

has complete integrals

(a)
$$(z + b)^2 = 4(ax + y)$$

(b)
$$kx(z + h) = k^2y + x^2$$

and deduce (b) from (a).

The two complete integrals may be derived from the characteristic equations. Consider the curve

$$y = 0, \quad x = k(z + h) \quad (13)$$

on the surface (b). At the intersections of (a) and (13) we have

$$(z + b)^2 - 4ak(z + h) - 4ak(b - h) = 0$$

and this has equal roots if

$$a^2k^2 - ak(b - h)$$

i.e., if $ak = 0$ or $b = h + ak$.

The subsystem given by $a = 0$ cannot be the desired one since its envelope does not depend on h and k . The second subsystem has equation

$$(z - h - ak)^2 = 4(ax - y)$$

i.e., $k^2 a^2 + 2a\{k(z - h) - 2x\} - (z - h)^2 - 4y = 0$

and this has envelope

$$\{k(z - h) - 2x\}^2 = \{(z - h)^2 - 4y\}k^2$$

which reduces to

$$kx(z + h) = k^2y + x^2$$

Next, we shall outline the procedure for determining an integral surface which circumscribes a given surface. Two surfaces are said to circumscribe each other if they touch along a curve, e.g., a conicoid and its enveloping cylinder. It should be noted that the curve of contact need not be a plane curve. We shall suppose that (3) is a complete integral of the partial differential equation (1) and that we wish to find, by using (3), an integral surface of (1) which circumscribes the surface Σ whose equation is

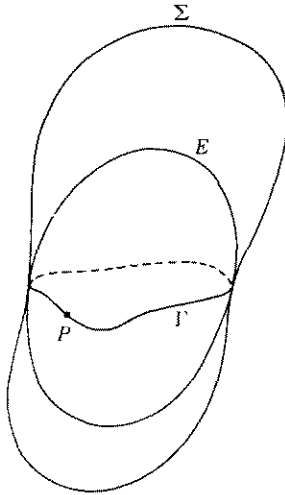

Figure 18

$$v(x, y, z) = 0 \tag{14}$$

If we have a surface E

$$u(x, y, z) = 0 \tag{15}$$

of the required kind, then it will be one of three kinds (a), (b), (c) listed above. We shall consider the possibility (b), since it is the one which occurs most frequently.

Suppose that the surface E touches the given surface Σ along a curve Γ (cf. Fig. 18). Since E is the envelope of a one-parameter subsystem S of the two-parameter system (3), it is touched at each of its points, and, in particular, at each point P of Γ , by a member S_p of the subsystem S . Now, since S_p touches E at P , it also touches Σ at P . Hence equation (15) is the equation of the envelope of a set of surfaces (3) which touch the surface (14). We now proceed to find the surfaces (3) which touch Σ and see if they provide a solution of the problem.

The surface (3) touches the surface (15) if, and only if, the equations (3), (14), and

$$\frac{f_x}{\psi_x} = \frac{f_y}{\psi_y} = \frac{f_z}{\psi_z} \tag{16}$$

are consistent. The condition for this is the eliminant of x , y , and z from these four equations, i.e., a relation of the form

$$\chi(a, b) = 0 \tag{17}$$

between a and b . This equation factorizes into a set of relations

$$b = \phi_1(a), \quad b = \phi_2(a), \quad \dots \quad (18)$$

each of which defines a subsystem of (3) whose members touch (14). The points of contact lie on the surface whose equation is obtained by eliminating a and b from the equations (16) and (18). The curve Γ is the intersection of this surface with Σ . Each of the relations (18) defines a subsystem whose envelope E touches Σ along Γ .

Example 14. Show that the only integral surface of the equation

$$2q(z - px - qy) = 1 + q^2$$

which is circumscribed about the paraboloid $2x = y^2 + z^2$ is the enveloping cylinder which touches it along its section by the plane $y + 1 = 0$.

The equation is of Clairaut type with complete integral

$$z = ax + by + \frac{b^2 + 1}{2b} \quad (19)$$

Equation (14) has the form

$$2x = y^2 + z^2 \quad (20)$$

so that equations (16) become, in this case

$$\frac{a}{2} = \frac{b}{-2y} = \frac{-1}{-2z}$$

which give the relations

$$y = -\frac{b}{a}, \quad z = \frac{1}{a} \quad (21)$$

Eliminating x between equations (19) and (21), we have

$$ab^2 + 2b^2y - abz^2 - 2bz + b^2 + 1 = 0$$

and eliminating y and z from this equation and the equations (21), we find that

$$(b - a)(b^2 + 1) = 0$$

so that the relation $b = a$ defines a subsystem whose envelope is a surface of the required kind. The envelope of the subsystem

$$\{2(x + y) + 1\}a^2 - 2az + 1 = 0$$

is obviously

$$z^2 = 2(x + y) + 1 \quad (22)$$

The surface (20) touches the surface (22) where

$$(y + 1)^2 = 0$$

proving the stated result.

PROBLEMS

1. Find a complete integral of the equation $p^2x + qy = z$, and hence derive the equation of an integral surface of which the line $y = 1$, $x + z = 0$ is a generator.
2. Show that the integral surface of the equation

$$z(1 - q^2) = 2(px + qy)$$

which passes through the line $x = 1, y = hz + k$ has equation

$$(y - kx)^2 = z^2\{(1 + h^2)x - 1\}$$

3. Show that the differential equation

$$2xz + q^2 = x(xp + yq)$$

has a complete integral

$$z + a^2x = axy + bx^2$$

and deduce that

$$x(y + hx)^2 = 4(z - kx^2)$$

is also a complete integral.

4. Find the complete integral of the differential equation

$$xp(1 + q) = (y + z)q$$

corresponding to that integral of Charpit's equations which involves only q and x , and deduce that

$$(z + hx + k)^2 = 4hx(k - y)$$

is also a complete integral.

5. Find the integral surface of the differential equation

$$(y + zq)^2 = z^2(1 + p^2 + q^2)$$

circumscribed about the surface $x^2 - z^2 = 2y$.

6. Show that the integral surface of the equation $2y(1 + p^2) = pq$ which is circumscribed about the cone $x^2 + z^2 = y^2$ has equation

$$z^2 = y^2(4y^2 + 4x + 1)$$

13. Jacobi's Method

Another method, due to Jacobi, of solving the partial differential equation

$$F(x, y, z, p, q) = 0 \quad (1)$$

depends on the fact that if

$$u(x, y, z) = 0 \quad (2)$$

is a relation between x, y , and z , then

$$p = -\frac{u_1}{u_3}, \quad q = -\frac{u_2}{u_3} \quad (3)$$

where u_i denotes $\partial u / \partial x_i$ ($i = 1, 2, 3$). If we substitute from equations (3) into equation (1), we obtain a partial differential equation of the type

$$f(x, y, z, u_1, u_2, u_3) = 0 \quad (4)$$

in which the new dependent variable u does not appear.

The fundamental idea of Jacobi's method is the introduction of two further partial differential equations of the first order

$$g(x, y, z, u_1, u_2, u_3, a) = 0, \quad h(x, y, z, u_1, u_2, u_3, b) = 0 \quad (5)$$

involving two arbitrary constants a and b and such that:

- (a) Equations (4) and (5) can be solved for u_1, u_2, u_3 ;
- (b) The equation

$$du = u_1 dx + u_2 dy + u_3 dz \tag{6}$$

obtained from these values of u_1, u_2, u_3 is integrable.

When these functions have been found, the solution of equation (6) containing three arbitrary constants will be a complete integral of (4). The three constants are necessary if the given equation is (4); when, however, the equation is given in the form (1), we need only two arbitrary constants in the final solution. By taking different choices of our third arbitrary constant we get different complete integrals of the given equation.

As in Charpit's method, the main difficulty is in the determination of the auxiliary equations (5). We have, in effect, to find two equations which are compatible with (4). Now in Example 4 of Sec. 9 we showed that g and h would therefore have to be solutions of the linear partial differential equation

$$f_{u_1} \frac{\partial g}{\partial x} + f_{u_2} \frac{\partial g}{\partial y} + f_{u_3} \frac{\partial g}{\partial z} - f_x \frac{\partial g}{\partial u_1} - f_y \frac{\partial g}{\partial u_2} - f_z \frac{\partial g}{\partial u_3} = 0 \tag{7}$$

which has subsidiary equations

$$\frac{dx}{f_{u_1}} = \frac{dy}{f_{u_2}} = \frac{dz}{f_{u_3}} = \frac{du_1}{-f_x} = \frac{du_2}{-f_y} = \frac{du_3}{-f_z} \tag{8}$$

The procedure is then the same as in Charpit's method.

To illustrate the method we shall solve Example 7 of Sec. 10 in this way. Writing $p = -u_1/u_3, q = -u_2/u_3$, we see that the equation

$$p^2x + q^2y = z$$

becomes

$$xu_1^2 + yu_2^2 - zu_3^2 = 0$$

so that the auxiliary equations are

$$\frac{dx}{2u_1x} = \frac{dy}{2u_2y} = \frac{dz}{-2u_3z} = \frac{du_1}{-u_1^2} = \frac{du_2}{-u_2^2} = \frac{du_3}{u_3^2}$$

with solutions

$$xu_1^2 = a, \quad yu_2^2 = b$$

whence

$$u_1 = \left(\frac{a}{x}\right)^{\frac{1}{2}}, \quad u_2 = \left(\frac{b}{y}\right)^{\frac{1}{2}}, \quad u_3 = \left(\frac{a+b}{z}\right)^{\frac{1}{2}}$$

so that

$$u = 2(ax)^{\frac{1}{2}} + 2(by)^{\frac{1}{2}} + 2\{(a+b)z\}^{\frac{1}{2}} + c$$

Writing $b = 1, c = b$, we see that the solution $u = 0$ is equivalent to the solution derived in Sec. 10.

The advantage of the Jacobi method is that it can readily be generalized. If we have to solve an equation of the type

$$f_1(x_1, x_2, \dots, x_n, u_1, \dots, u_n) = 0 \quad (9)$$

where u_i denotes $\partial u / \partial x_i$ ($i = 1, 2, \dots, n$), then we find $n - 1$ auxiliary functions f_2, f_3, \dots, f_n from the subsidiary equations

$$\frac{dx_1}{f_{u_1}} = \frac{dx_2}{f_{u_2}} = \dots = \frac{dx_n}{f_{u_n}} = \frac{du_1}{-f_{x_1}} = \frac{du_2}{-f_{x_2}} = \dots = \frac{du_n}{-f_{x_n}}$$

involving $n - 1$ arbitrary constants. Solving these for u_1, u_2, \dots, u_n , we determine u by integrating the Pfaffian equation

$$du = \sum_{i=1}^n u_i dx_i$$

the solution so obtained containing n arbitrary constants. On the other hand, Charpit's method cannot be generalized directly.

PROBLEMS

1. Solve the problems of Sec. 10 by Jacobi's method.
2. Show that a complete integral of the equation

$$f\left(\frac{\partial u}{\partial x}, \frac{\partial u}{\partial y}, \frac{\partial u}{\partial z}\right) = 0$$

is

$$u = ax + by + \theta(a, b)z + c$$

where a, b , and c are arbitrary constants and $f(a, b, \theta) = 0$.

Find a complete integral of the equation

$$\frac{\partial u}{\partial x} + \frac{\partial u}{\partial y} + \frac{\partial u}{\partial z} = \frac{\partial u}{\partial x} \frac{\partial u}{\partial y} \frac{\partial u}{\partial z}$$

3. Show how to solve, by Jacobi's method, a partial differential equation of the type

$$f\left(x, \frac{\partial u}{\partial x}, \frac{\partial u}{\partial z}\right) = g\left(y, \frac{\partial u}{\partial y}, \frac{\partial u}{\partial z}\right)$$

and illustrate the method by finding a complete integral of the equation

$$2x^2y\left(\frac{\partial u}{\partial x}\right)^2 \frac{\partial u}{\partial z} - x^2 \frac{\partial u}{\partial y} - 2y\left(\frac{\partial u}{\partial x}\right)^2$$

4. Prove that an equation of the "Clairaut" form

$$x \frac{\partial u}{\partial x} + y \frac{\partial u}{\partial y} + z \frac{\partial u}{\partial z} = f\left(\frac{\partial u}{\partial x}, \frac{\partial u}{\partial y}, \frac{\partial u}{\partial z}\right)$$

is always soluble by Jacobi's method.

Hence solve the equation

$$\left(\frac{\partial u}{\partial x} + \frac{\partial u}{\partial y} + \frac{\partial u}{\partial z}\right) \left(x \frac{\partial u}{\partial x} + y \frac{\partial u}{\partial y} + z \frac{\partial u}{\partial z}\right) = 1$$

14. Applications of First-order Equations

The most important first-order partial differential equation occurring in mathematical physics is the Hamilton-Jacobi equation

$$\frac{\partial S}{\partial t} + H\left(q_1, q_2, \dots, q_n; \frac{\partial S}{\partial q_1}, \frac{\partial S}{\partial q_2}, \dots, \frac{\partial S}{\partial q_n}\right) = 0 \tag{1}$$

appropriate to the Hamiltonian $H(q_1, q_2, \dots, q_n; p_1, p_2, \dots, p_n)$ of a dynamical system of n generalized coordinates q_1, q_2, \dots, q_n and the conjugate momenta p_1, p_2, \dots, p_n . This is an equation in which the dependent variable S is absent, so it is of the type (9) of Sec. 13. From the considerations of that section we see that the equations of the characteristics are

$$\begin{aligned} \frac{dt}{1} &= \frac{dq_1}{\partial H / \partial p_1} = \dots = \frac{dq_n}{\partial H / \partial p_n} \\ &= \frac{dp_1}{-(\partial H / \partial q_1)} = \dots = \frac{dp_n}{-(\partial H / \partial q_n)} \end{aligned} \tag{2}$$

i.e., they are equivalent to the Hamiltonian equations of motion

$$\frac{dq_i}{dt} = \frac{\partial H}{\partial p_i}, \quad \frac{dp_i}{dt} = -\frac{\partial H}{\partial q_i} \quad i = 1, 2, \dots, n \tag{3}$$

A modified form of equation (1) is obtained by writing

$$S = -Wt + S_1$$

We then find that

$$H\left(q_1, \dots, q_n; \frac{\partial S_1}{\partial q_1}, \dots, \frac{\partial S_1}{\partial q_n}\right) = W \tag{4}$$

Suppose, for example, that a system with two degrees of freedom has Hamiltonian

$$H = \frac{Pp_x^2 + Qp_y^2}{2(X + Y)} + \frac{\xi + \eta}{X + Y} \tag{5}$$

where P, X, ξ are functions of x alone and Q, Y, η are functions of y alone. Then equation (4) becomes

$$\frac{1}{2}(Pp_x + Qp_y) - (\xi + \eta) - W(X + Y) = 0$$

Then one of the characteristic equations is

$$\frac{dx}{Pp_x} + \frac{dp_x}{\frac{1}{2}Pp_x - \xi' - WX'} = 0$$

Its solution

$$p_x = \{2(WX - \xi + a)\}^{\frac{1}{2}}$$

where a is an arbitrary constant. Similarly we could have shown that

$$q_y = \{2(WY - \eta - b)\}^{\frac{1}{2}}$$

where b is an arbitrary constant. Thus since p_x is a function of x alone and q_y is a function of y alone, we have

$$S = -Wt + \int \{2(WX - \xi - a)\}^{\frac{1}{2}} dx + \int \{2(WY - \eta - b)\}^{\frac{1}{2}} dy$$

showing that a solution of the Hamilton-Jacobi equation can always be found for a Hamiltonian of the form (5).

First-order partial differential equations arise frequently in the theory of stochastic processes. One such equation is the *Fokker-Planck equation*¹

$$\frac{\partial P}{\partial t} = \beta \frac{\partial}{\partial x} (Px) + D \frac{\partial^2 P}{\partial x^2} \quad (6)$$

which reduces in the case $D = 0$ to the first-order linear equation

$$\frac{\partial P}{\partial t} = \beta x \frac{\partial P}{\partial x} + \beta P \quad (7)$$

The physical interpretation of the variables in this equation is that P is the probability that a random variable has the value x at time t . For example, P might be the probability distribution of the position of a harmonically bound particle in Brownian movement or the probability distribution of the deflection x of an electrical noise trace at time t . It should be observed that this equation (6) is valid only if the random process has Gaussian distribution and is a Markoff process.

Probably the most important occurrence of first-order equations is in the theory of birth and death processes² connected with bacteria. Suppose, for example, that at time t there are exactly n live bacteria and that:

- (a) The probability of a bacterium dying in time $(t, t + \delta t)$ is $\mu_n \delta t$;
- (b) The probability of a bacterium reproducing in time $(t, t + \delta t)$ is $\lambda_n \delta t$;
- (c) The probability of the number of bacteria remaining constant in time $(t, t + \delta t)$ is $(1 - \lambda_n \delta t - \mu_n \delta t)$;
- (d) The probability of more than one birth or death occurring in time $(t, t + \delta t)$ is zero.

If we assume $P_n(t)$ is the probability of there being n bacteria at time t , then these assumptions lead to the equation

$$P_n(t + \delta t) = \lambda_{n-1} P_{n-1}(t) \delta t + \mu_{n+1} P_{n+1}(t) \delta t + \{1 - \lambda_n \delta t - \mu_n \delta t\} P_n(t)$$

¹ For a derivation of this equation see S. Chandrasekhar, *Rev. Modern Phys.*, **15**, 33 (1943).

² W. Feller, "An Introduction to Probability Theory and Its Applications" (Wiley, New York, 1950), p. 371.

which is equivalent to

$$\frac{\partial P_n}{\partial t} = \lambda_{n-1}P_{n-1}(t) + \mu_{n+1}P_{n+1}(t) - (\lambda_n + \mu_n)P_n(t) \quad (8)$$

In the general case λ_n, μ_n would depend on n and t ; if we assume that the probability of the birth or death of a bacterium is proportional to the number present, we write

$$\lambda_n = n\lambda, \quad \mu_n = n\mu \quad (9)$$

where λ and μ are constants, and equation (8) reduces to

$$\frac{\partial P_n}{\partial t} = \lambda(n-1)P_{n-1}(t) - (\lambda + \mu)nP_n(t) + \mu(n+1)P_{n+1}(t)$$

and if we introduce a generating function $\Phi(z, t)$ defined by the relation

$$\Phi(z, t) = \sum_{n=0}^{\infty} P_n(t)z^n$$

we see that this last equation is equivalent to the first-order linear equation

$$\frac{\partial \Phi}{\partial t} = (z-1)(\lambda z - \mu) \frac{\partial \Phi}{\partial z}$$

whose solution is readily shown (by the method of Sec. 4) to be

$$\Phi = f\left(\frac{\mu - \lambda z}{1 - z} e^{-(\lambda - \mu)t}\right) \quad (10)$$

where the function f is arbitrary. If there are m bacteria present at $t = 0$, then $\Phi = z^m$ at $t = 0$, so that

$$z^m = f\left(\frac{\mu - \lambda z}{1 - z}\right)$$

from which it follows that

$$f(\xi) = \left(\frac{\mu - \xi}{\lambda - \xi}\right)^m$$

hence at time t

$$\Phi = \left(\frac{\mu(1 - e^{(\lambda - \mu)t}) - z(\lambda - \mu e^{(\lambda - \mu)t})}{\mu - \lambda e^{(\lambda - \mu)t} - \lambda z(1 - e^{(\lambda - \mu)t})}\right)^m$$

is the coefficient of z^n in the power series expansion of this function.

If $\mu > \lambda$, then $\Phi \rightarrow 1$ as $t \rightarrow \infty$, so that the probability of ultimate extinction is unity.

Similar equations arise in the discussion of trunking problems (see Prob. 4 below), in which $\lambda_n = \lambda$, $\mu_n = n\mu$, and in birth and death problems governed by different assumptions from those we have made here (cf. Prob. 3 below).

PROBLEMS

1. It may be assumed that the rate of deposit or removal of sand on the bed of a river is $a(\partial v/\partial x)$, where a is a constant and v is the velocity of the water in the direction of the flow. If η , h denote the heights, above an arbitrary zero level, of the bed and of the water surface, respectively, show that the motion of η is governed by the first-order equation

$$(h - \eta)^2 \frac{\partial \eta}{\partial t} + m \frac{\partial \eta}{\partial x} = 0$$

where m is a constant. Assuming h to be constant, show that the general solution of this equation is

$$\eta = f \left\{ x - \frac{m}{(h - \eta)^2} t \right\}$$

where the function f is arbitrary.

If $\eta = \eta_0 \cos(2\pi x/\lambda)$ at $t = 0$, find the relation between η and x at time t .

2. Show that the general solution of the modified Fokker-Planck equation (7) is

$$P = \frac{1}{x} f(xe^{\beta t})$$

where the function f is arbitrary.

Show further that a solution of the full equation (6) is given by

$$P = Q \left(xe^{\beta t}, \frac{e^{2\beta t} - 1}{2\beta} \right) e^{\beta t}$$

where $Q(\xi, \tau)$ is a solution of the equation

$$\frac{\partial Q}{\partial \tau} + \frac{\partial^2 Q}{\partial \xi^2} = 0$$

3. The individuals in a competitive community breed and die according to the laws:

(a) Every individual has the same chance $\lambda \delta t$ of giving birth to a new individual in any infinitesimal time interval δt ;

(b) Every individual has the chance $\{x + \beta(n - 1)\} \delta t$ of dying in the interval δt , where n is the total number of individuals in the community.

(λ, x , and β are nonnegative constants, and the chances of birth and death are independent of each other). If $P_n(t)$ denotes the probability that at time t there are n individuals in the community, show that the probability-generating function satisfies the equation

$$\frac{\partial \Phi}{\partial t} = (z - 1) \left\{ (\lambda z - x) \frac{\partial \Phi}{\partial z} - \beta z \frac{\partial^2 \Phi}{\partial z^2} \right\}$$

Show that if $x = 0$ and λ and β are positive, it is possible for the probability distribution of the number of individuals to have a stable form (independent of t) with zero chance of extinction. Find $P_n(t)$ explicitly in this case, and show that the mean number of individuals is then

$$\frac{\lambda/\beta}{1 - \exp(-\lambda/\beta)}$$

4. The probability distribution of telephone conversations carried on over a certain number of lines may be thought of as governed by the laws:

(a) If a line is occupied, the probability of a conversation which started at time $t = 0$ ending in the interval $(t, t + \delta t)$ is $\mu \delta t$, where μ is a constant;

(b) The probability of an incoming call in the interval $(t, t + \delta t)$ is $\lambda \delta t$, where λ is a constant;

(c) If δt is small, the probability of two conversations stopping in time δt is negligible.

If $P_n(t)$ is the probability that n lines are being used at time t and $\Phi(z, t)$ is the corresponding probability-generating function, show that

$$\frac{\partial \Phi}{\partial t} = (z - 1) \left\{ \lambda \Phi - \mu \frac{\partial \Phi}{\partial z} \right\}$$

If m lines are occupied at $t = 0$, show that at time t

$$\Phi(z, t) = \{1 + (z - 1)e^{-\mu t}\}^m \exp \left\{ \frac{\lambda}{\mu} (z - 1)(1 - e^{-\mu t}) \right\}$$

MISCELLANEOUS PROBLEMS

1. Show that any surface of revolution whose axis passes through the origin satisfies the equation

$$\begin{vmatrix} u & v & w \\ u_x & v_x & w_x \\ u_y & v_y & w_y \end{vmatrix} = 0$$

where $u = x + zp$, $v = y - zq$, $w = xq - yp$.

2. Show that the integral surfaces of the differential equation

$$(z + 3y) \frac{\partial z}{\partial x} + 3(z - x) \frac{\partial z}{\partial y} + (x + 3y) = 0$$

are of revolution about the line $x = -3y = z$, and find the integral surface through the curve

$$x^2 - y^2 + z^2 = a^2, \quad x - y + z = 2a$$

3. If the expression

$$(y^2 + z) dx + (x^2 + z) dy$$

is an exact differential in x and y , show that $z = 2xy + f(x + y)$, where f is arbitrary. Find f if $z = 2y + 1$ when $x = 0$.

4. The equation $P dx^2 + Q dx dy + R dy^2 = 0$, in which P, Q, R are functions of x and y , represents the projection on $z = 0$ of a network of curves on a surface $u(x, y, z) = 0$. Show that the curves are orthogonal if

$$P(u_y^2 + u_z^2) - Qu_x u_y + R(u_x^2 + u_z^2) = 0$$

5. Find the partial differential equation of the first order of which a complete integral is

$$(x - a)^2 + (y - b)^2 = z^2 \cot^2 \gamma$$

where a, b are constants.

Prove that another complete integral can be found which represents all planes making an angle γ with the plane $z = 0$.

6. Find the family of surfaces which represents the solution of the partial differential equation

$$(x + z) \frac{\partial z}{\partial x} + (y + z) \frac{\partial z}{\partial y} + z = 0$$

and obtain the integral surface which contains the circle $x^2 + y^2 = a^2$, $z = a$.

7. Find the equation of the integral surface of the differential equation

$$x^3 \frac{\partial z}{\partial x} + y(3x^2 + y) \frac{\partial z}{\partial y} = z(2x^2 + y)$$

which passes through the parabola $x = 1, y^2 = z - y$.

8. Solve the equation

$$(p - q)(x + y) = z$$

and determine the equation of the surface which satisfies this equation and passes through the curve

$$x = y^2 + z = 0, \quad x = z^2$$

9. Show that the integral surfaces of

$$(xp + yq)(x^2 + y^2 + a^2) = z(x^2 + y^2)$$

are generated by conics, and find the integral surface through the curve $x = 2z, x^2 + y^2 = 4a^2$.

10. Find the general solution of

$$y \frac{\partial u}{\partial x} + x \frac{\partial u}{\partial y} = 1$$

in the domain $0 < y < x$. Find the solution which equals x when $y = \frac{1}{2}x$.

11. Find the general integral of the equation

$$\{my(x + y) + nz^2\} \frac{\partial z}{\partial x} + \{lx(x + y) + nz^2\} \frac{\partial z}{\partial y} = (lx + my)z$$

and deduce the equation of the integral surface which passes through the curve

$$2x = z + z^3, \quad 2y = z - z^3$$

12. Prove that for the equation

$$z + px + qy - 1 - pqx^2y^2 = 0$$

the characteristic strips are given by

$$x = \frac{1}{B + Ce^{-t}}, \quad y = \frac{1}{A + De^{-t}}, \quad z = E - (AC + BD)e^{-t}$$

$$p = A(B + Ce^{-t})^2, \quad q = B(A + De^{-t})^2$$

where A, B, C, D , and E are arbitrary constants. Hence find the integral surface which passes through the line $z = 0, x = y$.

13. Find a complete integral of the equation

$$4(x + y)z + (p + q)(x + y)^2 + 2(p - q)(x^2 - y^2) - 4(p^2 - q^2)$$

14. Show that the characteristic equations of the differential equation

$$(q^2 + 1)z^2 = 2pxz + x^2$$

have an integral $qz = ax$, and find the corresponding complete integral of the differential equation, showing that it represents a set of conicoids of revolution.

15. The normal to a given surface at a variable point P meets the coordinate planes XOY and YOZ in A and B , respectively. If AB is bisected by the plane ZOX , show that the surface satisfies the differential equation

$$z = \frac{x}{p} - \frac{2y}{q}$$

Find a complete integral of this equation.

5. The normal to a given surface at a variable point P meets the sphere $x^2 + y^2 + z^2 = 1$ in the points A and B . If AB is bisected by the plane $z = 0$, show that the surface satisfies the differential equation

$$z(p^2 + q^2) - px - qy = 0$$

Find a complete integral of this equation.

6. Show that the characteristic equations of the differential equation

$$z + xp - x^2yq^2 - x^3pq = 0$$

have an integral $qx = a$, and find the corresponding complete integral of the differential equation.

7. Find a complete integral of the equation $p^2x + qy = z$, and hence derive the equation of an integral surface of which the line $y = 1, x + z = 0$ is a generator.

8. Find the complete integral of the differential equation

$$p^2x + pqy - 2pz = x$$

corresponding to the integral of the characteristic equations involving q and y alone, in the form

$$2z = ay^2 + bx^2 - \frac{1}{b}$$

Deduce the integral surface through the line $y = 1, x = z$.

9. Show that a necessary and sufficient condition that a surface should be developable is that it satisfies a differential equation of the form $f(p, q) = 0$.

Deduce that a necessary and sufficient condition that a surface should be developable is that its second derivatives $r(x, y), s(x, y), t(x, y)$ satisfy the equation $rt = s^2$.

Show that the only integral surfaces of the differential equation

$$2q(z - xp - 2yq) + x = 0$$

which are developable are the cones

$$(z + ax)^2 = 2y(x + b)$$

Find the integral surfaces through the curve $z = 0, x^3 + 2y = 0$.

At any point P on a surface the normal meets the plane $z = 0$ in the point N . Show that the differential equation of the system of surfaces with the property that $OP^2 = ON^2$, where O is the origin, is

$$z(p^2 + q^2) + 2(px + qy) = z$$

Obtain a complete integral of this equation, and hence find the two surfaces with the above property which pass through the circle $x^2 + z^2 = 1, y = 0$.

If any integral surface of a partial differential equation of the first order remains an integral surface when it is given an arbitrary screw motion about the z axis, prove that the equation must be of the form

$$F(xp + yq, xq - yp, x^2 + y^2) = 0$$

If a differential equation of this type admits the quadric

$$ax^2 + by^2 + cz^2 = 1$$

as an integral surface, show that the characteristic curves which lie on this quadric are its intersections with the family of paraboloids $z = kxy$.

Chapter 3

PARTIAL DIFFERENTIAL EQUATIONS OF THE SECOND ORDER

In the last chapter we considered the solution of partial differential equations of the first order. We shall now proceed to the discussion of equations of the second order. In this chapter we shall confine ourselves to a preliminary discussion of these equations, and then in the following three chapters we shall consider in more detail the three main types of linear partial differential equation of the second order. Though we are concerned mainly with second-order equations, we shall also have something to say about partial differential equations of order higher than the second.

1. The Origin of Second-order Equations

Suppose that the function z is given by an expression of the type

$$z = f(u) + g(v) + w \quad (1)$$

where f and g are arbitrary functions of u and v , respectively, and u , v , and w are prescribed functions of x and y . Then writing

$$p = \frac{\partial z}{\partial x}, \quad q = \frac{\partial z}{\partial y}, \quad r = \frac{\partial^2 z}{\partial x^2}, \quad s = \frac{\partial^2 z}{\partial x \partial y}, \quad t = \frac{\partial^2 z}{\partial y^2} \quad (2)$$

we find, on differentiating both sides of (1) with respect to x and y , respectively, that

$$p = f'(u)u_x + g'(v)v_x + w_x$$

$$q = f'(u)u_y + g'(v)v_y + w_y$$

and hence that

$$r = f''(u)u_x^2 + g''(v)v_x^2 + f'(u)u_{xx} + g'(v)v_{xx} + w_{xx}$$

$$s = f''(u)u_x u_y + g''(v)v_x v_y + f'(u)u_{xy} + g'(v)v_{xy} + w_{xy}$$

$$t = f''(u)u_y^2 + g''(v)v_y^2 + f'(u)u_{yy} + g'(v)v_{yy} + w_{yy}$$

We now have five equations involving the four arbitrary quantities f' ,

f'' , g' , g'' . If we eliminate these four quantities from the five equations, we obtain the relation

$$\begin{vmatrix} p - W_x & u_x & v_x & 0 & 0 \\ q - W_y & u_y & v_y & 0 & 0 \\ r - W_{xx} & u_{xx} & v_{xx} & u_x^2 & v_x^2 \\ s - W_{xy} & u_{xy} & v_{xy} & u_x u_y & v_x v_y \\ t - W_{yy} & u_{yy} & v_{yy} & u_y^2 & v_y^2 \end{vmatrix} = 0 \quad (3)$$

which involves only the derivatives p, q, r, s, t and known functions of x and y . It is therefore a partial differential equation of the second order. Furthermore if we expand the determinant on the left-hand side of equation (3) in terms of the elements of the first column, we obtain an equation of the form

$$Rr + Ss + Tt + Pp + Qq = W \quad (4)$$

where R, S, T, P, Q, W are known functions of x and y . Therefore the relation (1) is a solution of the second-order linear partial differential equation (4). It should be noticed that the equation (4) is of a particular type: the dependent variable z does not occur in it.

As an example of the procedure of the last paragraph, suppose that

$$z = f(x + ay) + g(x - ay) \quad (5)$$

where f and g are arbitrary functions and a is a constant. If we differentiate (5) twice with respect to x , we obtain the relation

$$r = f'' + g''$$

while if we differentiate it twice with regard to y , we obtain the relation

$$t = a^2 f'' - a^2 g''$$

that functions z which can be expressed in the form (5) satisfy the partial differential equation

$$t = a^2 r \quad (6)$$

Similar methods apply in the case of higher-order equations. It is readily shown that any relation of the type

$$z = \sum_{r=1}^n f_r(v_r) \quad (7)$$

where the functions f_r are arbitrary and the functions v_r are known, leads to a linear partial differential equation of the n th order.

The partial differential equations we have so far considered in this section have been linear equations. Naturally it is not only linear equations in which we are interested. In fact, we have already entered a nonlinear equation of the second order; we saw in Example of Chap. 2 that if the surface $z = f(x, y)$ is a developable surface, the function f must be a solution of the second-order nonlinear equation

$$rt - s^2 = 0$$

PROBLEMS

1. Verify that the partial differential equation

$$\frac{\partial^2 z}{\partial x^2} - \frac{\partial^2 z}{\partial y^2} = \frac{2z}{x}$$

is satisfied by

$$z = \frac{1}{x} \phi(y - x) + \phi'(y - x)$$

where ϕ is an arbitrary function.

2. If
- $u = f(x + iy) + g(x - iy)$
- , where the functions
- f
- and
- g
- are arbitrary, show that

$$\frac{\partial^2 u}{\partial x^2} + \frac{\partial^2 u}{\partial y^2} = 0$$

3. Show that if
- f
- and
- g
- are arbitrary functions of a single variable, then

$$u = f(x - vt + izy) + g(x - vt - izy)$$

is a solution of the equation

$$\frac{\partial^2 u}{\partial x^2} + \frac{\partial^2 u}{\partial y^2} = \frac{1}{c^2} \frac{\partial^2 u}{\partial t^2}$$

provided that $\alpha^2 = 1 - v^2/c^2$.

4. If

$$z = f(x^2 - y) + g(x^2 + y)$$

where the functions f, g are arbitrary, prove that

$$\frac{\partial^2 z}{\partial x^2} - \frac{1}{x} \frac{\partial z}{\partial x} = 4x^2 \frac{\partial^2 z}{\partial y^2}$$

5. A variable
- z
- is defined in terms of variables
- x, y
- as the result of eliminating
- t
- from the equations

$$z = tx + yf(t) + g(t)$$

$$0 = x + yf'(t) + g'(t)$$

Prove that, whatever the functions f and g may be, the equation

$$rt - s^2 = 0$$

is satisfied.

2. Second-order Equations in Physics

Partial differential equations of the second order arise frequently in mathematical physics. In fact, it is for this reason that the study of such equations is of great practical value. The next three chapters will be devoted to the study of the solution of types of second-order equation occurring most often in physics. For the moment we shall merely show how such equations arise.

As a first example we consider the flow of electricity in a long insulated cable. We shall suppose that the flow is one-dimensional so that the

current i and the voltage E at any point in the cable can be completely specified by one spatial coordinate x and a time variable t . If we consider the fall of potential in a linear element of length δx situated at the point x , we find that

$$-\delta E = iR \delta x + L \delta x \frac{\partial i}{\partial t} \quad (1)$$

where R is the series resistance per unit length and L is the inductance per unit length. If there is a capacitance to earth of C per unit length and a conductance G per unit length, then

$$-\delta i = GE \delta x + C \delta x \frac{\partial E}{\partial t} \quad (2)$$

The relations (1) and (2) are equivalent to the pair of partial differential equations

$$\frac{\partial E}{\partial x} + Ri + L \frac{\partial i}{\partial t} = 0 \quad (3)$$

$$\frac{\partial i}{\partial x} + GE + C \frac{\partial E}{\partial t} = 0 \quad (4)$$

Differentiating equation (3) with regard to x , we obtain

$$\frac{\partial^2 E}{\partial x^2} + R \frac{\partial i}{\partial x} + L \frac{\partial^2 i}{\partial x \partial t} = 0 \quad (5)$$

and similarly differentiating equation (4) with regard to t , we obtain

$$\frac{\partial^2 i}{\partial x \partial t} + G \frac{\partial E}{\partial t} + C \frac{\partial^2 E}{\partial t^2} = 0 \quad (6)$$

Eliminating $\partial i/\partial x$ and $\partial^2 i/\partial x \partial t$ from equations (4), (5), and (6), we find that E satisfies the second-order partial differential equation

$$\frac{\partial^2 \phi}{\partial x^2} = LC \frac{\partial^2 \phi}{\partial t^2} + (RC + LG) \frac{\partial \phi}{\partial t} + RG\phi \quad (7)$$

Similarly if we differentiate (3) with regard to t , (4) with regard to x , and eliminate $\partial^2 E/\partial x \partial t$ and $\partial E/\partial x$ from the resulting equations and equation (3), we find that i is also a solution of equation (7).

Equation (7), which is called the *telegraphy equation* by Poincaré and others, reduces to a simple form in two special cases. If the leakage to ground is small, so that G and L may be taken to be zero, equation (7) reduces to the form

$$\frac{\partial^2 \phi}{\partial x^2} = \frac{1}{k} \frac{\partial \phi}{\partial t} \quad (8)$$

where $k = (RC)^{-1}$ is a constant. This equation is also sometimes called the telegraphy equation; we shall refer to it as the *one-dimensional diffusion equation*.

On the other hand, if we are dealing with high-frequency phenomena on a cable, the terms involving the time derivatives predominate. If we look at equations (3) and (4), we see that this is equivalent to taking G and R to be zero in equation (7), in which case it reduces to

$$\frac{\partial^2 \phi}{\partial x^2} = \frac{1}{c^2} \frac{\partial^2 \phi}{\partial t^2} \quad (9)$$

where $c = (LC)^{-\frac{1}{2}}$. This equation is sometimes referred to, in this context, as the radio equation; we shall refer to it as the *one-dimensional wave equation*.

A simple partial differential equation of the second order, different in character from either equation (8) or (9), arises in electrostatics. By Gauss' law of electrostatics we know that the flux of the electric vector \mathbf{E} out of a surface S bounding an arbitrary volume V is 4π times the charge contained in V . Thus if ρ is the density of electric charge, we have

$$\int_S \mathbf{E} \cdot d\mathbf{s} = 4\pi \int_V \rho \, d\tau$$

Using Green's theorem in the form

$$\int_S \mathbf{E} \cdot d\mathbf{s} = \int_V \operatorname{div} \mathbf{E} \, d\tau$$

and remembering that the volume V is arbitrary, we see that Gauss' law is equivalent to the equation

$$\operatorname{div} \mathbf{E} = 4\pi\rho \quad (10)$$

Now it is readily shown that the electrostatic field is characterized by the fact that the vector \mathbf{E} is derivable from a potential function ϕ by the equation

$$\mathbf{E} = -\operatorname{grad} \phi \quad (11)$$

Eliminating \mathbf{E} between equations (10) and (11), we find that ϕ satisfies the equation

$$\nabla^2 \phi = 4\pi\rho = 0 \quad (12)$$

where we have written ∇^2 for the operator $\operatorname{div}(\operatorname{grad})$, which in rectangular Cartesian coordinates takes the form

$$\frac{\partial^2}{\partial x^2} + \frac{\partial^2}{\partial y^2} + \frac{\partial^2}{\partial z^2} \quad (13)$$

Equation (12) is known as *Poisson's equation*. In the absence of charges, ρ is zero, and equation (12) reduces to the simple form

$$\nabla^2 \phi = 0 \quad (14)$$

This equation is known as *Laplace's equation* or the *harmonic equation*.

we are dealing with a problem in which the potential function ϕ does not vary with z , we then find that ∇ is replaced by

$$\nabla_1^2 = \frac{\partial^2}{\partial x^2} + \frac{\partial^2}{\partial y^2} \tag{15}$$

and that Laplace's equation becomes

$$\nabla_1^2 \phi = 0 \tag{16}$$

in a form which we shall refer to as the *two-dimensional harmonic equation*. The Laplacian operator ∇^2 occurs frequently in mathematical physics, and in a great many problems it is advantageous to transform from Cartesian coordinates x, y, z to another orthogonal curvilinear system given by the equations

$$u_1 = u_1(x, y, z), \quad u_2 = u_2(x, y, z), \quad u_3 = u_3(x, y, z) \tag{17}$$

The transformation of the Laplacian operator in these circumstances is best effected by the aid of vector calculus,¹ which shows that in the u_1, u_2, u_3 system

$$\nabla^2 V = \frac{1}{h_1 h_2 h_3} \left\{ \frac{\partial}{\partial u_1} \left(\frac{h_2 h_3}{h_1} \frac{\partial V}{\partial u_1} \right) + \frac{\partial}{\partial u_2} \left(\frac{h_3 h_1}{h_2} \frac{\partial V}{\partial u_2} \right) + \frac{\partial}{\partial u_3} \left(\frac{h_1 h_2}{h_3} \frac{\partial V}{\partial u_3} \right) \right\} \tag{18}$$

where

$$h_i^2 = \left(\frac{\partial x}{\partial u_i} \right)^2 + \left(\frac{\partial y}{\partial u_i} \right)^2 + \left(\frac{\partial z}{\partial u_i} \right)^2 \quad i = 1, 2, 3 \tag{19}$$

PROBLEMS

1. Show that Maxwell's equations

$$\begin{aligned} \operatorname{div} \mathbf{E} &= 4\pi\rho, & \operatorname{div} \mathbf{H} &= 0 \\ \operatorname{curl} \mathbf{E} &= -\frac{1}{c} \frac{\partial \mathbf{H}}{\partial t}, & \operatorname{curl} \mathbf{H} &= \frac{4\pi\mathbf{i}}{c} + \frac{1}{c} \frac{\partial \mathbf{E}}{\partial t} \end{aligned}$$

governing the behavior of the electric and magnetic field strengths \mathbf{E} and \mathbf{H} possess solutions of the form

$$\mathbf{H} = \operatorname{curl} \mathbf{A}, \quad \mathbf{E} = -\frac{1}{c} \frac{\partial \mathbf{A}}{\partial t} - \operatorname{grad} \phi$$

where the vector \mathbf{A} and the scalar ϕ satisfy the inhomogeneous equations

$$\nabla^2 \mathbf{A} - \frac{1}{c^2} \frac{\partial^2 \mathbf{A}}{\partial t^2} = \frac{4\pi}{c} \mathbf{i} = 0, \quad \nabla^2 \phi - \frac{1}{c^2} \frac{\partial^2 \phi}{\partial t^2} = 4\pi\rho = 0$$

respectively.

2. A heavy chain of uniform line density is suspended vertically from one end. Taking the origin of coordinates at the position of equilibrium of the lower

¹ H. Lass, "Vector and Tensor Analysis" (McGraw-Hill, New York, 1950), p. 51-54.

(free) end and the x axis along the equilibrium position of the chain, pointing vertically *upward*, show that in small oscillations about the equilibrium position the horizontal deflection y of the chain satisfies the equation

$$\frac{\partial^2 y}{\partial t^2} + g \frac{\partial}{\partial x} \left(x \frac{\partial y}{\partial x} \right)$$

where g is the acceleration due to gravity.

By changing the independent variables to t and ξ , where $\xi^2 = 4x/g$, show that this equation is equivalent to

$$\frac{\partial^2 y}{\partial \xi^2} = \frac{1}{\xi} \frac{\partial y}{\partial \xi} - \frac{\partial^2 y}{\partial t^2}$$

3. Plane sound waves are being propagated in a gas of normal average density ρ_0 contained in a pipe whose cross-sectional area A varies along its length. If p, ρ denote the pressure and density at any point in the plane whose coordinate is x and if during the motion the plane normally at x is displaced to $x + \xi$, show that if the disturbance is small,

$$\rho_0 \frac{\partial^2 \xi}{\partial t^2} = \frac{\partial p}{\partial x}, \quad p = -\rho_0 \left\{ 1 - \frac{1}{A} \frac{\partial}{\partial x} (A\xi) \right\}$$

Hence show that ξ satisfies the equation

$$\frac{\partial^2 \xi}{\partial t^2} = c^2 \frac{\partial}{\partial x} \left\{ \frac{1}{A} \frac{\partial}{\partial x} (A\xi) \right\}$$

where $c^2 = dp/d\rho$.

If $A = A_0 e^{kx}$, show that the equation possesses a solution of the form $\xi = e^{-1/2 kx} \zeta$, where

$$\frac{\partial^2 \zeta}{\partial x^2} - \frac{1}{4} k^2 \zeta = \frac{1}{c^2} \frac{\partial^2 \zeta}{\partial t^2}$$

and that if $A = A_0 x^{2m-1}$, it has a solution $\xi = x^{1-m} \zeta$, where

$$\frac{\partial^2 \zeta}{\partial x^2} + \frac{1}{x} \frac{\partial \zeta}{\partial x} - \frac{m^2}{x^2} \zeta = \frac{1}{c^2} \frac{\partial^2 \zeta}{\partial t^2}$$

4. Show that in cylindrical coordinates ρ, z, ϕ defined by the relations

$$x = \rho \cos \phi, \quad y = \rho \sin \phi, \quad z = z$$

Laplace's equation $\nabla^2 V = 0$ takes the form

$$\frac{\partial^2 V}{\partial \rho^2} + \frac{1}{\rho} \frac{\partial V}{\partial \rho} + \frac{1}{\rho^2} \frac{\partial^2 V}{\partial \phi^2} + \frac{\partial^2 V}{\partial z^2} = 0$$

5. Show that in polar coordinates r, θ, ϕ defined by the equations

$$x = r \sin \theta \cos \phi, \quad y = r \sin \theta \sin \phi, \quad z = r \cos \theta$$

Laplace's equation $\nabla^2 V = 0$ takes the form

$$\frac{1}{r^2} \left(\frac{\partial}{\partial r} r^2 \frac{\partial V}{\partial r} \right) + \frac{1}{r^2 \sin \theta} \frac{\partial}{\partial \theta} \left(\sin \theta \frac{\partial V}{\partial \theta} \right) + \frac{1}{r^2 \sin^2 \theta} \frac{\partial^2 V}{\partial \phi^2} = 0$$

3. Higher-order Equations in Physics

The differential equations in the physical problems we have so far considered, and indeed most of those considered in a first course, are all

second-order equations and are all linear. It is therefore significant to show that not all physical problems lead to partial differential equations which are either linear or of the second order.

For example, if we consider the state of stress in a two-dimensional solid,¹ we find that it is specified by three stress components σ_x , σ_y , τ_{xy} which satisfy the equilibrium conditions

$$\frac{\partial \sigma_x}{\partial x} + \frac{\partial \tau_{xy}}{\partial y} + \rho X = 0 \quad (1)$$

$$\frac{\partial \tau_{xy}}{\partial x} + \frac{\partial \sigma_y}{\partial y} + \rho Y = 0 \quad (2)$$

where X and Y are the components of the body force per unit mass. Suppose, for simplicity, that there are no body forces, so that we may take X and Y to be zero; then it is obvious that the expressions

$$\sigma_x = \frac{\partial^2 \phi}{\partial y^2}, \quad \tau_{xy} = -\frac{\partial^2 \phi}{\partial x \partial y}, \quad \sigma_y = \frac{\partial^2 \phi}{\partial x^2} \quad (3)$$

satisfy the equilibrium equations for any arbitrary function ϕ .

So far we have not specified the nature of the material of which the body is composed. If the body is elastic, i.e., if the relation between the stresses and strains is a simple generalization of Hooke's law, then it is known that the components of stress satisfy compatibility relations of the form (ν denoting Poisson's ratio)

$$\frac{\partial^2}{\partial y^2} \{\sigma_x - \nu(\sigma_x + \sigma_y)\} + \frac{\partial^2}{\partial x^2} \{\sigma_y - \nu(\sigma_x + \sigma_y)\} = 2 \frac{\partial^2 \tau_{xy}}{\partial x \partial y} \quad (4)$$

Substituting from the equations (3) into equation (4), we see that ϕ must satisfy the fourth-order linear partial differential equation

$$\frac{\partial^4 \phi}{\partial x^4} + 2 \frac{\partial^4 \phi}{\partial x^2 \partial y^2} + \frac{\partial^4 \phi}{\partial y^4} = 0 \quad (5)$$

which may be written symbolically as

$$\nabla_1^4 \phi = 0 \quad (6)$$

Because of its relation to $\nabla_1^2 \phi = 0$, this is called the *two-dimensional biharmonic equation*. The same equation arises in the discussion of the slow motion of a viscous fluid.²

If, instead of assuming that the solid body was elastic, we had assumed that it was ideally plastic, so that the stresses satisfy a Hencky-Mises condition of the form

$$\left(\frac{1}{2}\sigma_x - \frac{1}{2}\sigma_y\right)^2 + \tau_{xy}^2 = k^2 \quad (7)$$

¹ A. E. H. Love, "A Treatise on the Mathematical Theory of Elasticity," 4th ed. (Cambridge, London, 1934), p. 138.

² H. Lamb, "Hydrodynamics," 6th ed. (Cambridge, London, 1932), p. 602.

instead of equation (4), we find that ϕ satisfies the second order non-linear partial differential equation

$$\left(\frac{\partial^2 \phi}{\partial x^2} - \frac{\partial^2 \phi}{\partial y^2}\right)^2 + 4\left(\frac{\partial^2 \phi}{\partial x \partial y}\right)^2 = 4k^2 \tag{8}$$

PROBLEMS

1. Show that

$$\nabla_1^4(x^2y) = x\nabla_1^4y = 4\frac{\partial}{\partial x}(\nabla_1^2y)$$

and deduce that if $\psi_1, \psi_2, \psi_3, \psi_4$, are arbitrary solutions of $\nabla_1^2\psi = 0$, the function

$$\psi = x^2\psi_1 + y^2\psi_2 - \psi_3 - \psi_4$$

is a general solution of $\nabla_1^4\psi = 0$.

2. Transform the equation $\nabla_1^4V = 0$ to plane polar coordinates r and θ , and show that if V is a plane biharmonic function which depends on r alone, then

$$V = c_1r^2 \log r + c_2 \log r + c_3r^2 + c_4$$

where c_1, c_2, c_3, c_4 are constants.

3. Prove:

(a)
$$\nabla_1^2(r^2y) = r^2\nabla_1^2y + 4y - 4r\frac{\partial y}{\partial r}$$

(b)
$$\nabla_1^2\left(r\frac{\partial y}{\partial r}\right) = \frac{1}{r}\frac{\partial}{\partial r}\left(r^2\nabla_1^2y\right)$$

Deduce that if $\nabla_1^2y = 0$, then $\nabla_1^4(r^2y) = 0$.

4. Verify that $\phi = (1 + \xi x)e^{-\xi x - \xi y}$ is a solution of the biharmonic equation $\nabla_1^4\phi = 0$ if ξ is a constant.

Hence derive expressions for components of stress $\sigma_x, \sigma_y, \tau_{xy}$ which satisfy the equilibrium and compatibility relations and are such that all the components tend to zero as $x \rightarrow \infty$ and $\sigma_y = -p_0 \cos(\xi y), \tau_{xy} = 0$ when $x = 0$.

5. Show that the equations of plastic equilibrium in the plane are equivalent to the equation

$$\frac{\partial^2}{\partial x \partial y} (k^2 - \tau_{xy}^2)^{\frac{1}{2}} = \pm \frac{1}{2} \left\{ \frac{\partial^2 \tau_{xy}}{\partial x^2} - \frac{\partial^2 \tau_{xy}}{\partial y^2} \right\}$$

and verify that $c_1 + c_2y$ is the only solution of this equation of the form $f(y)$. Taking $\tau_{xy} = -ky/a$, calculate σ_x, σ_y .

4. Linear Partial Differential Equations with Constant Coefficients

We shall now consider the solution of a very special type of linear partial differential equation, that with constant coefficients. Such an equation can be written in the form

$$F(D, D')z = f(x, y) \tag{1}$$

where $F(D, D')$ denotes a differential operator of the type

$$F(D, D') = \sum_r \sum_s c_{rs} D^r D'^s \quad (2)$$

in which the quantities c_{rs} are constants, and $D = \partial/\partial x$, $D' = \partial/\partial y$.

The most general solution, i.e., one containing the correct number of arbitrary elements, of the corresponding homogeneous linear partial differential equation

$$F(D, D')z = 0 \quad (3)$$

is called the *complementary function* of the equation (1), just as in the theory of ordinary differential equations. Similarly any solution of the equation (1) is called a *particular integral* of (1).

As in the theory of linear ordinary differential equations, the basic theorem is:

Theorem 1. *If u is the complementary function and z_1 a particular integral of a linear partial differential equation, then $u + z_1$ is a general solution of the equation.*

The proof of this theorem is obvious. Since the equations (1) and (3) are of the same kind, the solution $u + z_1$ will contain the correct number of arbitrary elements to qualify as a general solution of (1). Also

$$F(D, D')u = 0, \quad F(D, D')z_1 = f(x, y)$$

that
$$F(D, D')(u + z_1) = f(x, y)$$

showing that $u + z_1$ is in fact a solution of equation (1). This completes the proof.

Another result which is used extensively in the solution of differential equations is:

Theorem 2. *If u_1, u_2, \dots, u_n are solutions of the homogeneous linear partial differential equation $F(D, D')z = 0$, then*

$$\sum_{r=1}^n c_r u_r$$

where the c_r 's are arbitrary constants, is also a solution.

The proof of this is immediate, since

$$F(D, D')(c_r u_r) = c_r F(D, D')u_r$$

$$\therefore F(D, D') \sum_{r=1}^n c_r u_r = \sum_{r=1}^n c_r F(D, D')u_r$$

is zero for any set of functions u_r . Therefore

$$\begin{aligned} F(D, D') \sum_{r=1}^n c_r u_r &= \sum_{r=1}^n F(D, D')(c_r u_r) \\ &= \sum_{r=1}^n c_r F(D, D')u_r \\ &= 0 \end{aligned}$$

We classify linear differential operators $F(D, D')$ into two main types, which we shall treat separately. We say that:

(a) $F(D, D')$ is *reducible* if it can be written as the product of linear factors of the form $D + aD' + b$, with a, b constants;

(b) $F(D, D')$ is *irreducible* if it cannot be so written.

For example, the operator

$$D^2 - D'^2$$

which can be written in the form

$$(D + D')(D - D')$$

is reducible, whereas the operator

$$D^2 - D'$$

which cannot be decomposed into linear factors, is irreducible.

(a) *Reducible Equations.* The starting point of the theory of reducible equations is the result:

Theorem 3. *If the operator $F(D, D')$ is reducible, the order in which the linear factors occur is unimportant.*

The theorem will be proved if we can show that

$$\begin{aligned} (\alpha_r D + \beta_r D' + \gamma_r)(\alpha_s D + \beta_s D' + \gamma_s) \\ = (\alpha_s D + \beta_s D' + \gamma_s)(\alpha_r D + \beta_r D' + \gamma_r) \end{aligned} \quad (4)$$

for any reducible operator can be written in the form

$$F(D, D') = \prod_{r=1}^n (\alpha_r D + \beta_r D' + \gamma_r) \quad (5)$$

and the theorem follows at once. The proof of (4) is immediate, since both sides are equal to

$$\begin{aligned} \alpha_r \alpha_s D^2 + (\alpha_s \beta_r + \alpha_r \beta_s) D D' + \beta_r \beta_s D'^2 + (\gamma_s \alpha_r + \gamma_r \alpha_s) D \\ + (\gamma_s \beta_r + \gamma_r \beta_s) D' + \gamma_r \gamma_s \end{aligned}$$

Theorem 4. *If $\alpha_r D + \beta_r D' + \gamma_r$ is a factor of $F(D, D')$ and $\phi_r(\xi)$ is an arbitrary function of the single variable ξ , then if $\alpha_r \neq 0$,*

$$u_r = \exp\left(-\frac{\gamma_r x}{\alpha_r}\right) \phi_r(\beta_r x - \alpha_r y)$$

is a solution of the equation $F(D, D') z = 0$.

By direct differentiation we have

$$\begin{aligned} Du_r &= -\frac{\gamma_r}{\alpha_r} u_r + \beta_r \exp\left(-\frac{\gamma_r x}{\alpha_r}\right) \phi_r'(\beta_r x - \alpha_r y) \\ D'u_r &= -\alpha_r \exp\left(-\frac{\gamma_r x}{\alpha_r}\right) \phi_r'(\beta_r x - \alpha_r y) \end{aligned}$$

so that

$$(\alpha_r D + \beta_r D' + \gamma_r)u_r = 0 \quad (6)$$

Now by Theorem 3

$$F(D, D')u_r = \left\{ \prod_{s=1}^n (\alpha_s D - \beta_s D' + \gamma_s) \right\} (\alpha_r D - \beta_r D' + \gamma_r) u_r \quad (7)$$

prime after the product denoting that the factor corresponding to r is omitted. Combining equations (6) and (7), we see that

$$F(D, D')u_r = 0$$

which proves the theorem.

By an exactly similar method we can prove:

Theorem 5. If $\beta_r D' + \gamma_r$ is a factor of $F(D, D')$ and $\phi(\xi)$ is an arbitrary function of the single variable ξ , then if $\beta_r \neq 0$,

$$u_r = \exp\left(-\frac{\gamma_r y}{\beta_r}\right) \phi_r(\beta_r x)$$

is a solution of the equation $F(D, D')z = 0$.

In the decomposition of $F(D, D')$ into linear factors we may get multiple factors of the type $(\alpha_r D - \beta_r D' + \gamma_r)^n$. The solution corresponding to a factor of this type can be obtained by a simple application of Theorems 4 and 5. For example, if $n = 2$, we wish to find solutions of the equation

$$(\alpha_r D - \beta_r D' + \gamma_r)^2 z = 0 \quad (8)$$

we let

$$Z = (\alpha_r D - \beta_r D' + \gamma_r) z$$

then

$$(\alpha_r D - \beta_r D' + \gamma_r) Z = 0$$

which according to Theorem 4 has solution

$$Z = \exp\left(-\frac{\gamma_r x}{\alpha_r}\right) \phi_r(\beta_r x - \alpha_r y)$$

where $\phi_r = 0$. To find the corresponding function z we have therefore to solve the first-order linear partial differential equation

$$\alpha_r \frac{\partial z}{\partial x} + \beta_r \frac{\partial z}{\partial y} + \gamma_r z = e^{-\gamma_r x / \alpha_r} \phi_r(\beta_r x - \alpha_r y) \quad (9)$$

Using the method of Sec. 4 of Chap. 2, we see that the auxiliary equations are

$$\frac{dx}{\alpha_r} = \frac{dy}{\beta_r} = \frac{dz}{-\gamma_r z + e^{-\gamma_r x / \alpha_r} \phi_r(\beta_r x - \alpha_r y)}$$

with solution

$$\beta_r x - \alpha_r y = c_1$$

Substituting this in the auxiliary equations, we get the

$$\frac{dx}{\alpha_r} = \frac{dz}{-\gamma_r z - e^{-\gamma_r x / \alpha_r} \phi_r(c_1)}$$

which is a first-order linear equation with solution

$$z = \frac{1}{\alpha_r} \left\{ \phi_r(c_1)x + c_2 \right\} e^{-\alpha_r x}$$

Equation (9), and hence equation (8), therefore has solution

$$z = \{x\phi_r(\beta_r x - \alpha_r y) + \psi_r(\beta_r x - \alpha_r y)\} e^{-\alpha_r x}$$

where the functions ϕ_r, ψ_r are arbitrary.

This result is readily generalized (by induction) to give:

Theorem 6. *If $(\alpha_r D + \beta_r D' + \gamma_r)^n$ ($\alpha_r \neq 0$) is a factor of $F(D, D')$ and if the functions $\phi_{r1}, \dots, \phi_{rn}$ are arbitrary, then*

$$\exp\left(-\frac{\gamma_r x}{\alpha_r}\right) \sum_{s=1}^n x^{s-1} \phi_{rs}(\beta_r x - \alpha_r y)$$

is a solution of $F(D, D')z = 0$.

Similarly the generalization of Theorem 5 is:

Theorem 7. *If $(\beta_r D' + \gamma_r)^m$ is a factor of $F(D, D')$ and if the functions $\phi_{r1}, \dots, \phi_{rm}$ are arbitrary, then*

$$\exp\left(-\frac{\gamma_r y}{\beta_r}\right) \sum_{s=1}^m x^{s-1} \phi_{rs}(\beta_r x)$$

is a solution of $F(D, D')z = 0$.

We are now in a position to state the complementary function of the equation (1) when the operator $F(D, D')$ is reducible. As a result of Theorems 4 and 6, we see that if

$$F(D, D') = \prod_{r=1}^n (\alpha_r D + \beta_r D' + \gamma_r)^{m_r} \tag{10}$$

and if none of the α_r 's is zero, then the corresponding complementary function is

$$u = \sum_{r=1}^n \exp\left(-\frac{\gamma_r x}{\alpha_r}\right) \sum_{s=1}^{m_r} x^{s-1} \phi_{rs}(\beta_r x - \alpha_r y) \tag{11}$$

where the functions ϕ_{rs} ($s = 1, \dots, n_r; r = 1, \dots, n$) are arbitrary. If some of the α 's are zero, the necessary modifications to the expression (11) can be made by means of Theorems 5 and 7. From equation (10) we see that the order of equation (3) is $m_1 + m_2 + \dots + m_n$; since the solution (11) contains the same number of arbitrary functions, it has the correct number and is thus the complete complementary function.

To illustrate the procedure we consider a simple special case:

Example 1. *Solve the equation*

$$\frac{\partial^4 z}{\partial x^4} + \frac{\partial^4 z}{\partial y^4} = 2 \frac{\partial^4 z}{\partial x^2 \partial y^2}$$

In the notation of this section this equation can be written in the form

$$(D - D')^2(D + D')z = 0$$

so that by the rule (11) the solution of it is

$$z = x\phi_1(x - y) + \phi_2(x - y) + x\psi_1(x - y) + \psi_2(x - y)$$

where the functions ϕ_1 , ϕ_2 , ψ_1 , ψ_2 are arbitrary.

Having found the complementary function of equation (1), we need only find a particular integral to complete the solution. This is found by a method similar to that employed in the proof of Theorem 6. If we write

$$z_1 = \prod_{r=1}^n (z_r D + \beta_r D' + \gamma_r)z \quad (12)$$

then equation (1) is equivalent to the first-order linear equation

$$z_1 \frac{\partial z_1}{\partial x} + \beta_1 \frac{\partial z_1}{\partial y} + \gamma_1 z_1 = f(x, y)$$

a particular integral of which can easily be found by Lagrange's method. Substituting this particular value of z_1 in (12), we obtain an inhomogeneous equation of order $n - 1$. Repeating the process, we finally arrive at a first-order equation for z . To illustrate the process we consider:

Example 2. Find the solution of the equation

$$\frac{\partial^2 z}{\partial x^2} - \frac{\partial^2 z}{\partial y^2} = x - y$$

This equation may be written in the form

$$(D + D')(D - D')z = x - y$$

so that the complementary function is

$$\phi_1(x - y) + \phi_2(x - y)$$

where ϕ_1 and ϕ_2 are arbitrary. To determine a particular integral we write

$$z_1 = (D - D')z \quad (13)$$

Then the equation for z_1 is

$$(D - D')z_1 = x - y$$

which is a first-order linear equation with solution

$$z_1 = \frac{1}{4}(x - y)^2 + f(x - y)$$

where f is arbitrary. Since we are seeking only a particular integral, we may take $f = 0$. Substituting this value of z_1 into (13), we find that the equation for the particular integral is

$$\frac{\partial z}{\partial x} - \frac{\partial z}{\partial y} = \frac{1}{4}(x - y)^2$$

which has solution

$$z = \frac{1}{4}x(x - y)^2 + f(x - y)$$

in which f is arbitrary. Taking $f = 0$ we obtain the particular integral

$$z = \frac{1}{4}x(x-y)^2$$

Hence the general solution of the equation may be written in the form

$$z = \frac{1}{4}x(x-y)^2 + \phi_1(x-y) + \phi_2(x-y)$$

where the functions ϕ_1 and ϕ_2 are arbitrary.

(b) *Irreducible Equations.* When the operator $F(D, D')$ is irreducible, it is not always possible to find a solution with the full number of arbitrary functions, but it is possible to construct solutions which contain as many arbitrary constants as we wish. The method of deriving such solutions depends on a theorem which we shall now prove. This theorem is true for reducible as well as irreducible operators, but it is only in the irreducible case that we make use of it.

Theorem 8. $F(D, D')e^{ax+by} = F(a, b)e^{ax+by}$

The proof of this theorem follows from the fact that $F(D, D')$ is made up of terms of the type

$$c_{rs}D^r D'^s$$

and $D^r(e^{ax+by}) = a^r e^{ax+by}$, $D'^s(e^{ax+by}) = b^s e^{ax+by}$

so that $(c_{rs}D^r D'^s)(e^{ax+by}) = c_{rs}a^r b^s e^{ax+by}$

The theorem follows by recombining the terms of the operator $F(D, D')$.

A similar result which is used in determining particular integrals is:

Theorem 9. $F(D, D')(e^{ax+by}\phi(x, y)) = e^{ax+by}F(D+a, D'+b)\phi(x, y)$.

The proof is direct, making use of Leibnitz's theorem for the r th derivative of a product to show that

$$\begin{aligned} D^r(e^{ax}\phi) &= \sum_{p=0}^r {}^r C_p (D^p e^{ax})(D^{r-p}\phi) \\ &= e^{ax} \left(\sum_{p=0}^r {}^r C_p a^p D^{r-p} \right) \phi \\ &= e^{ax} (D+a)^r \phi \end{aligned}$$

To determine the complementary function of an equation of the type (1) we split the operator $F(D, D')$ into factors. The reducible factors are treated by method (a). The irreducible factors are treated as follows. From Theorem 8 we see that e^{ax+by} is a solution of the equation

$$F(D, D')z = 0 \quad (14)$$

provided $F(a, b) = 0$, so that

$$z = \sum_r c_r \exp(ax + by) \quad (15)$$

in which a_r, b_r, c_r are all constants, is also a solution provided that a_r, b_r are connected by the relation

$$F(a_r, b_r) = 0 \quad (16)$$

in this way we can construct a solution of the homogeneous equation (4) containing as many arbitrary constants as we need. The series (15) need not be finite, but if it is infinite, it is necessary that it should be uniformly convergent if it has to be, in fact, a solution of equation (14). The discussion of the convergence of such a series is difficult, involving as it does the coefficients c_n , the pairs (a_n, b_n) , and the values of the variables x and y .

Example 3. Show that the equation

$$\frac{\partial^2 z}{\partial x^2} = \frac{1}{k} \frac{\partial z}{\partial t}$$

admits solutions of the form

$$\sum_{n=0}^{\infty} c_n \cos (nx + i t_n) e^{-k n^2 t}$$

This follows immediately from the fact that $e^{ax + by + ct}$ is a solution only if

$$a^2 = \frac{b}{k}$$

and this relation is satisfied if we take $a = \pm i n, b = -k n^2$.

To find the particular integral of the equation (1) we write it symbolically as

$$z = \frac{1}{F(D, D')} f(x, y) \tag{17}$$

We can often expand the operator F^{-1} by the binomial theorem and then interpret the operators D^{-1}, D'^{-1} as integrations.

Example 4. Find a particular integral of the equation

$$(D^2 - D')z = 2y - x^2$$

We put the equation in the form

$$z = \frac{1}{D^2 - D'} (2y - x^2)$$

Now we can write

$$\begin{aligned} \frac{1}{D^2 - D'} &= \left(1 - \frac{D'}{D^2}\right)^{-1} \frac{1}{D^2} \\ &= \dots \frac{1}{D^2} + \frac{D'}{D^4} + \frac{D'^2}{D^6} + \dots \\ z &= \frac{1}{D^2} (2y - x^2) + \frac{1}{D^2} D' (2y - x^2) \\ &= \frac{1}{2} y^2 + x^2 y + \frac{1}{D^2} (2) \\ &= x^2 y \end{aligned}$$

When $f(x, y)$ is made of terms of the form $\exp (ax + by)$, we obtain

(as a result of Theorem 8) a particular integral made up of terms of the form

$$\frac{1}{F(a,b)} \exp(ax + by)$$

except if it happens that $F(a,b) = 0$.

Example 5. Find a particular integral of the equation

$$(D^2 - D')z = e^{2x+y}$$

In this case $F(D,D') = D^2 - D'$, $a = 2$, and $b = 1$, so that $F(a,b) = 3$, and the particular integral is

$$\frac{1}{3}e^{2x+y}$$

In cases in which $F(a,b) = 0$ it is often possible to make use of Theorem 9. If we have to solve

$$F(D,D')z = ce^{ax+by}$$

where c is a constant, we let

$$z = we^{ax+by}$$

then by Theorem 9 we have

$$F(D + a, D' + b)w = c \quad (18)$$

and it is sometimes possible to obtain a particular integral of this equation.

Example 6. Find a particular integral of the equation

$$(D^2 - D')z = e^{x+y}$$

In this case $F(D,D') = D^2 - D'$, $a = 1$, $b = 1$, and $F(a,b) = 0$. However,

$$F(D + a, D' + b) = (D + 1)^2 - (D' + 1) = D^2 + 2D - D'$$

and so equation (18) becomes in this case

$$(D^2 + 2D - D')w = 1$$

which is readily seen to have particular integrals $\frac{1}{2}x$ and $-y$. Thus $\frac{1}{2}xe^{x+y}$ and $-ye^{x+y}$ are particular integrals of the original equation.

When the function $f(x,y)$ is of the form of a trigonometric function, it is possible to make use of the last two methods by expressing it as a combination of exponential functions with imaginary exponents, but it is often simpler to use the method of undetermined coefficients.

Example 7. Find a particular integral of the equation

$$(D^2 - D')z = A \cos(lx + my)$$

where A, l, m are constants.

To find a particular integral we let

$$z = c_1 \cos(lx + my) + c_2 \sin(lx + my)$$

and substitute in the left-hand side of the original equation. Equating the

coefficient of the sine to zero and that of the cosine to A , we obtain the equations

$$\begin{aligned} mc_1 - l^2c_2 &= 0 \\ -l^2c_1 - mc_2 &= A \end{aligned}$$

for the determination of c_1 and c_2 . Solving these equations for c_1 and c_2 , we obtain the particular integral

$$z = \frac{A}{m^2 - l^4} \{m \sin(lx - mt) + l^2 \cos(lx - mt)\}$$

PROBLEMS

1. Show that the equation

$$\frac{\partial^2 y}{\partial t^2} + 2k \frac{\partial y}{\partial t} - c^2 \frac{\partial^2 y}{\partial x^2}$$

possesses solutions of the form

$$\sum_{r=0}^{\infty} c_r e^{-\lambda t} \cos(x_r x - \varepsilon_r) \cos(\omega_r t - \delta_r)$$

where $c_r, x_r, \varepsilon_r, \delta_r$ are constants and $\omega_r^2 = \alpha_r^2 c^2 - k^2$.

2. Solve the equations

(a) $r + s - 2t = e^{x-y}$
 (b) $r - s + 2q - z = x^2 y^2$
 (c) $r + s - 2t - p - 2q = 0$

3. Solve the equation

$$\frac{\partial^3 z}{\partial x^3} - 2 \frac{\partial^3 z}{\partial x^2 \partial y} - \frac{\partial^3 z}{\partial x \partial y^2} + 2 \frac{\partial^3 z}{\partial y^3} = e^{x+y}$$

4. Find the solution of the equation

$$\nabla_1^2 z = e^{-x} \cos y$$

which tends to zero as $x \rightarrow \infty$ and has the value $\cos y$ when $x = 0$.

5. Show that a linear partial differential equation of the type

$$\sum_{r,s} c_{r,s} x^r y^s \frac{\partial^{r+s} z}{\partial x^r \partial y^s} = f(x,y)$$

may be reduced to one with constant coefficients by the substitutions

$$\xi = \log x, \quad \eta = \log y$$

Hence solve the equation

$$x^2 r - y^2 t - xp - yq = \log x$$

5. Equations with Variable Coefficients

We shall now consider equations of the type

$$Rr + Ss + Tt + f(x,y,z,p,q) = 0 \tag{1}$$

which may be written in the form

$$L(z) \cdot f(x, y, z, p, q) = 0 \quad (2)$$

where L is the differential operator defined by the equation

$$L = R \frac{\partial^2}{\partial x^2} - S \frac{\partial^2}{\partial x \partial y} + T \frac{\partial^2}{\partial y^2} \quad (3)$$

in which R , S , T are continuous functions of x and y possessing continuous partial derivatives of as high an order as necessary. By a suitable change of the independent variables we shall show that any equation of the type (2) can be reduced to one of three *canonical forms*. Suppose we change the independent variables from x , y to ξ , η , where

$$\xi = \xi(x, y), \quad \eta = \eta(x, y)$$

and we write $z(x, y)$ as $\zeta(\xi, \eta)$; then it is readily shown that equation (1) takes the form

$$A(\xi_x, \xi_y) \frac{\partial^2 \zeta}{\partial \xi^2} + 2B(\xi_x, \xi_y; \eta_x, \eta_y) \frac{\partial^2 \zeta}{\partial \xi \partial \eta} - A(\eta_x, \eta_y) \frac{\partial^2 \zeta}{\partial \eta^2} = F(\xi, \eta, \zeta, \zeta_\xi, \zeta_\eta) \quad (4)$$

where
$$A(u, v) = Ru^2 + Sur + Tv^2 \quad (5)$$

$$B(u_1, v_1; u_2, v_2) = Ru_1u_2 + \frac{1}{2}S(u_1v_2 + u_2v_1) + Tv_1v_2 \quad (6)$$

and the function F is readily derived from the given function f .

The problem now is to determine ξ and η so that equation (4) takes the simplest possible form. The procedure is simple when the discriminant $S^2 - 4RT$ of the quadratic form (5) is *everywhere* either positive, negative, or zero, and we shall discuss these three cases separately.

Case (a): $S^2 - 4RT > 0$. When this condition is satisfied, the roots λ_1, λ_2 of the equation

$$Rx^2 + Sx + T = 0 \quad (7)$$

are real and distinct, and the coefficients of $\partial^2 \zeta / \partial \xi^2$ and $\partial^2 \zeta / \partial \eta^2$ in equation (4) will vanish if we choose ξ and η such that

$$\frac{\partial \xi}{\partial x} = \lambda_1 \frac{\partial \xi}{\partial y}, \quad \frac{\partial \eta}{\partial x} = \lambda_2 \frac{\partial \eta}{\partial y}$$

From Sec. 4 of Chap. 2 we see that a suitable choice would be

$$\xi = f_1(x, y), \quad \eta = f_2(x, y) \quad (8)$$

where $f_1 = c_1$, $f_2 = c_2$ are the solutions of the first-order ordinary differential equations

$$\frac{dy}{dx} - \lambda_1(x, y) = 0, \quad \frac{dy}{dx} + \lambda_2(x, y) = 0 \quad (9)$$

respectively.

Now it is easily shown that, in general,

$$A(\xi_x, \xi_y)A(\eta_x, \eta_y) - B^2(\xi_x, \xi_y; \eta_x, \eta_y) = (4RT - S^2)(\xi_x \eta_y - \xi_y \eta_x)^2 \quad (10)$$

so that when the A 's are zero

$$B^2 = (S^2 - 4RT)(\xi_x \eta_y - \xi_y \eta_x)^2$$

and since $S^2 - 4RT > 0$, it follows that $B^2 > 0$ and therefore that we may divide both sides of the equation by it. Hence if we make the substitutions defined by the equations (8) and (9), we find that equation (1) is reduced to the form

$$\frac{\partial^2 \zeta}{\partial \xi \partial \eta} = \phi(\xi, \eta, \zeta, \zeta_\xi, \zeta_\eta) \quad (11)$$

Example 8. Reduce the equation

$$\frac{\partial^2 z}{\partial x^2} = x^2 \frac{\partial^2 z}{\partial y^2}$$

to canonical form.

In this case $R = 1$, $S = 0$, $T = -x^2$, so that the roots of equation (7) are $\xi = x$ and the equations (9) are

$$\frac{d\eta}{dx} = x - 0$$

so that we may take $\xi = y - \frac{1}{2}x^2$, $\eta = y - \frac{1}{2}x^2$. It is then readily verified that the equation takes the canonical form

$$\frac{\partial^2 \zeta}{\partial \xi \partial \eta} = \frac{1}{4(\xi - \eta)} \left(\frac{\partial \zeta}{\partial \xi} - \frac{\partial \zeta}{\partial \eta} \right)$$

Case (b): $S^2 - 4RT = 0$. In such circumstances the roots of equation (7) are equal. We define the function ξ precisely as in case (a) and take η to be any function of x, y which is independent of ξ . We then have, as before, $A(\xi_x, \xi_y) = 0$, and hence, from equation (10), $B(\xi_x, \xi_y; \eta_x, \eta_y) = 0$. On the other hand, $A(\eta_x, \eta_y) \neq 0$; otherwise η would be a function of ξ . Putting $A(\xi_x, \xi_y)$ and B equal to zero and dividing by $A(\eta_x, \eta_y)$, we see that the canonical form of equation (1) is, in this case,

$$\frac{\partial^2 \zeta}{\partial \eta^2} = \phi(\xi, \eta, \zeta, \zeta_\xi, \zeta_\eta) \quad (12)$$

Example 9. Reduce the equation

$$\frac{\partial^2 z}{\partial x^2} - 2 \frac{\partial^2 z}{\partial x \partial y} + \frac{\partial^2 z}{\partial y^2} = 0$$

to canonical form and hence solve it.

In this example $R = 1$, $S = 2$, $T = 1$, so that it is case (b), with

$$1 - 2x + x^2 = 0$$

in place of equation (7). We thus have $\lambda_1 = -1$, so that we may take $\xi = x - y$,

$\eta = x + y$. We then find that the equation reduces to the canonical form

$$\frac{\partial^2 \zeta}{\partial \eta^2} = 0$$

which is readily shown to have solution

$$\zeta = \eta f_1(\xi) + f_2(\xi)$$

where the functions f_1 and f_2 are arbitrary. Hence the original equation has solution

$$z = (x - y)f_1(x - y) + f_2(x - y)$$

Case (c): $S^2 - 4RT < 0$. This is formally the same as case (a) except that now the roots of equation (7) are complex. If we go through the procedure outlined in case (a), we find that the equation (1) reduces to the form (11) but that the variables ξ, η are not real but are in fact complex conjugates. To get a real canonical form we make the further transformation

$$\alpha = \frac{1}{2}(\xi + \eta), \quad \beta = \frac{1}{2}i(\eta - \xi)$$

and it is readily shown that

$$\frac{\partial^2 \zeta}{\partial \xi \partial \eta} = \frac{1}{4} \left(\frac{\partial^2 \zeta}{\partial \alpha^2} + \frac{\partial^2 \zeta}{\partial \beta^2} \right)$$

so that the desired canonical form is

$$\frac{\partial^2 \zeta}{\partial \alpha^2} + \frac{\partial^2 \zeta}{\partial \beta^2} = \psi(\alpha, \beta, \zeta, \zeta_\alpha, \zeta_\beta) \quad (13)$$

To illustrate this procedure we consider:

Example 10. Reduce the equation

$$\frac{\partial^2 z}{\partial x^2} - x^2 \frac{\partial^2 z}{\partial y^2} = 0$$

to canonical form.

In this instance $\lambda_1 = ix, \lambda_2 = -ix$, so that we may take $\xi = iy + \frac{1}{2}x^2, \eta = -iy + \frac{1}{2}x^2$, and hence $\alpha = \frac{1}{2}x^2, \beta = y$. It is left as an exercise to the reader to show that the equation then transforms to the canonical form

$$\frac{\partial^2 \zeta}{\partial \alpha^2} + \frac{\partial^2 \zeta}{\partial \beta^2} = -\frac{1}{2\alpha} \frac{\partial \zeta}{\partial \alpha}$$

We classify second-order equations of the type (1) by their canonical forms; we say that an equation of this type is:

- (a) *Hyperbolic* if $S^2 - 4RT > 0$,
- (b) *Parabolic* if $S^2 - 4RT = 0$,
- (c) *Elliptic* if $S^2 - 4RT < 0$.

The one-dimensional wave equation

$$\frac{\partial^2 z}{\partial x^2} = \frac{\partial^2 z}{\partial y^2}$$

hyperbolic with canonical form

$$\frac{\partial^2 \zeta}{\partial \xi \partial \eta} = 0$$

the one-dimensional diffusion equation

$$\frac{\partial^2 z}{\partial x^2} = \frac{\partial z}{\partial y}$$

parabolic, being already in canonical form, and the two-dimensional harmonic equation

$$\frac{\partial^2 z}{\partial x^2} + \frac{\partial^2 z}{\partial y^2} = 0$$

elliptic and in canonical form.

PROBLEMS

1. Show how to find a solution containing two arbitrary functions of the equation
- $$x^2 \frac{\partial^2 z}{\partial x^2} + 2xy \frac{\partial^2 z}{\partial x \partial y} + y^2 \frac{\partial^2 z}{\partial y^2} = f(x, y).$$
- Hence solve the equation

$$x^2 - 4xy + y^2 = 1$$

2. Show that, by a simple substitution, the equation

$$Rr + Pp = W$$

can be reduced to a linear partial differential equation of the first order, and outline a procedure for determining the solution of the original equation.

Illustrate the method by finding the solutions of the equations:

$$(a) \quad xr + 2p = 2y$$

$$(b) \quad x^2 + q = e^{x+y}$$

3. If the functions R, P, Z contain y but not x , show that the solution of the equation

$$Rr + Pp + Zz = W$$

can be obtained from that of a certain second-order ordinary differential equation with constant coefficients.

Hence solve the equation

$$yr + (y^2 - 1)p + yz = e^y$$

4. Reduce the equation

$$(n-1)^2 \frac{\partial^2 z}{\partial x^2} - y^{2n} \frac{\partial^2 z}{\partial y^2} = ny^{2n-1} \frac{\partial z}{\partial y}$$

to canonical form, and find its general solution.

5. Reduce the equation

$$y^2 \frac{\partial^2 z}{\partial x^2} - 2xy \frac{\partial^2 z}{\partial x \partial y} + x^2 \frac{\partial^2 z}{\partial y^2} - \frac{y^2}{x} \frac{\partial z}{\partial x} + \frac{x^2}{y} \frac{\partial z}{\partial y}$$

to canonical form, and hence solve it.

6. Characteristic Curves of Second-order Equations

We shall now consider briefly the *Cauchy problem* for the second-order partial differential equation

$$Rr \dots Ss + Tt + f(x, y, z, p, q) = 0 \quad (1)$$

in which R , S , and T are functions of x and y only. In other words, we wish to consider the problem of determining the solution of equation (1) such that on a given space curve Γ it takes on prescribed values of z and $\partial z / \partial n$, where n is distance measured along the normal to the curve. This latter set of boundary conditions is equivalent to assuming that the values of x , y , z , p , q are determined on the curve, but it should be noted that the values of the partial derivatives p and q cannot be assigned arbitrarily along the curve. For if we take the freedom equations of the curve Γ to be

$$x = x_0(\tau), \quad y = y_0(\tau), \quad z = z_0(\tau) \quad (2)$$

then we must have at all points of Γ the relation

$$\dot{z}_0 = p_0 \dot{x}_0 + q_0 \dot{y}_0 \quad (3)$$

(where \dot{z}_0 denotes dz_0/dt , etc.), showing that p_0 and q_0 are not independent. The Cauchy problem is therefore that of finding the solution of equation (1) passing through the integral strip of the first order formed by the planar elements $(x_0, y_0, z_0, p_0, q_0)$ of the curve Γ .

At every point of the integral strip $p_0 = p_0(\tau)$, $q_0 = q_0(\tau)$, so that if we differentiate these equations with respect to τ , we obtain the relations

$$\dot{p}_0 = r \dot{x}_0 + s \dot{y}_0, \quad \dot{q}_0 = s \dot{x}_0 + t \dot{y}_0 \quad (4)$$

If we solve the three equations (1) and (4) for r , s , t , we find that

$$\frac{r}{\Delta_1} = \frac{-s}{\Delta_2} = \frac{t}{\Delta_3} = \frac{-1}{\Delta}$$

where

$$\Delta_1 = \begin{vmatrix} S & T & f \\ \dot{y}_0 & 0 & -\dot{p}_0 \\ \dot{x}_0 & \dot{y}_0 & -\dot{q}_0 \end{vmatrix}, \text{ etc.} \quad \text{and} \quad \Delta = \begin{vmatrix} R & S & T \\ \dot{x}_0 & \dot{y}_0 & 0 \\ 0 & \dot{x}_0 & \dot{y}_0 \end{vmatrix}$$

If $\Delta \neq 0$, we can therefore easily calculate the expressions for the second-order derivatives r_0 , s_0 , and t_0 along the curve Γ .

The third-order partial differential coefficients of z can similarly be calculated at every point of Γ by differentiating equation (1) with respect to x and y , respectively, making use of the relations

$$\dot{r}_0 = z_{xx} \dot{x}_0 + z_{xy} \dot{y}_0$$

etc., and solving as in the previous case.

Proceeding in this way, we can calculate the partial derivatives of

every order at the points of the curve Γ . The value of the function z at neighboring points can therefore be obtained by means of Taylor's theorem for functions of two independent variables. The Cauchy problem therefore possesses a solution as long as the determinant Δ does not vanish. In the elliptic case $4RT - S^2 > 0$, so that $\Delta \neq 0$ always holds, and the derivatives, of all orders, of z are uniquely determined. It is reasonable to conjecture that the solution so obtained is analytic in the domain of analyticity of the coefficients of the differential equation being discussed; constructing a proof of this conjecture was one of the famous problems propounded by Hilbert. The proof for the linear case was given first by Bernstein; that for the general case (1) was given later by Hopf and Lewy.

We must now consider the case in which the determinant Δ vanishes. Expanding Δ , we see that this condition is equivalent to the relation

$$Ry_0^2 - Sx_0y_0 + Tx_0^2 = 0 \quad (5)$$

If the projection of the curve Γ onto the plane $z = 0$ is a curve γ with equation

$$\xi(x, y) = c_0 \quad (6)$$

then we find that, as a result of differentiating with regard to τ ,

$$\xi_x \dot{x}_0 + \xi_y \dot{y}_0 = 0 \quad (7)$$

Eliminating the ratio \dot{x}_0/\dot{y}_0 between equations (5) and (7), we find that the condition $\Delta = 0$ is equivalent to the relation

$$A(\xi_x, \xi_y) = 0 \quad (8)$$

where the function A is that defined by equation (5) of Sec. 5. A curve γ in the xy plane satisfying the relation (8) is called a *characteristic base curve* of the partial differential equation (1), and the curve Γ of which it is the projection is called a *characteristic curve* of the same equation. The term *characteristic* is applied indiscriminately to both kinds of curves, since there is usually little danger of confusion arising as a result.

From the arguments of Sec. 5 it follows at once that there are two families of characteristics if the given partial differential equation is hyperbolic, one family if it is parabolic, and none if it is elliptic.

As we have defined it, a characteristic is a curve such that, given values of the dependent variable and its first-order partial derivatives at all points on it, Cauchy's problem does not possess a unique solution. We shall now show that this property is equivalent to one which is of more interest in physical applications, namely, that if there is a second-order discontinuity at one point of the characteristic, it must persist at all points.

To establish this property we consider a function ϕ of the independent

variables x and y which is continuous everywhere except at the points of the curve C whose equation is

$$\xi(x,y) = c \quad (9)$$

where $\xi(x,y)$ is any function (not necessarily the function ξ defined above) with as many derivatives as necessary. If P_0 is any point on this curve and P_1 and P_2 are neighboring points on opposite sides of the curve (cf. Fig. 19), then we define the *discontinuity* of the function ϕ at the point P_0 by the equation

$$[\phi]_{P_0} = \lim_{P_1, P_2 \rightarrow P_0} \{\phi(P_1) - \phi(P_2)\} \quad (10)$$

If the element of length along the directed tangent to the curve C at the point P_0 is $d\sigma$, then the tangential derivative of the function ϕ is defined to be

$$\frac{d\phi}{d\sigma} = \frac{\partial\phi}{\partial x} \cos(\sigma, x) + \frac{\partial\phi}{\partial y} \cos(\sigma, y)$$

and it is readily shown that this is equivalent to the expression

$$\frac{d\phi}{d\sigma} = \frac{\phi_x \xi_y(P_0) - \phi_y \xi_x(P_0)}{\{\xi_x^2(P_0) + \xi_y^2(P_0)\}^{1/2}} \quad (11)$$

The tangential derivative at P_0 is therefore continuous if the expression on the right-hand side of this equation is continuous at P_0 , and we say that $d\phi/d\sigma$ is continuous on

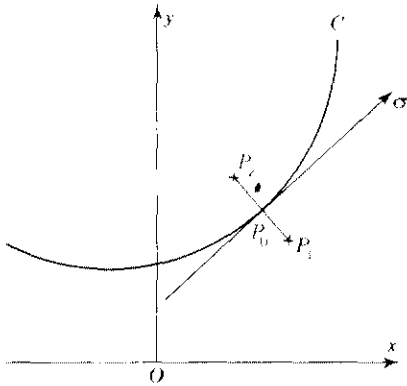

Figure 19

the curve C if this holds for all points P_0 on C .

Now let us suppose that the function $z(x,y)$ is a solution of the equation (1), where, for simplicity, we shall suppose that the function f is linear in p and q . We shall assume in addition that the function $z(x,y)$ is continuous and has continuous derivatives of all orders required except that its second derivatives are not all continuous at all points of the curve C defined by equation (9). In particular it is assumed that the first-order partial derivatives z_x and z_y have continuous tangential derivatives at all points of the curve C . It follows immediately from equation (11) that if the tangential derivative $dz_x/d\sigma$ is continuous at the point P_0 , so also is the expression

$$z_{xx} \xi_y(P_0) - z_{xy} \xi_x(P_0)$$

Now another way of saying that a function is continuous is to say that its discontinuity is zero at the point in question. We may therefore write

$$[z_{xx}] \xi_y(P_0) - [z_{xy}] \xi_x(P_0) = 0$$

By considering the other tangential derivative $dz_y/d\sigma$, we may similarly prove the relation

$$[z_{xy}] \xi_y(P_0) - [z_{yx}] \xi_x(P_0) = 0$$

and hence that

$$\frac{[z_{xy}]}{\xi_x^2(P_0)} = \frac{[z_{yx}]}{\xi_y(P_0)\xi_x(P_0)} = \frac{[z_{yy}]}{\xi_y^2(P_0)} \tag{12}$$

Letting each of the ratios in the equations (12) be equal to λ , we may write these equations in the form

$$[z_{xx}] = \lambda \xi_x^2(P_0), \quad [z_{xy}] = \lambda \xi_x(P_0)\xi_y(P_0), \quad [z_{yy}] = \lambda \xi_y^2(P_0) \tag{13}$$

If we now transform the independent variables in our problem from x and y to ξ and η , where ξ is the function introduced through the curve C and η is such that, for any function $\eta(\xi, \eta)$, $d\eta/d\sigma = \partial\eta/\partial\eta$. The quantity λ occurring in equations (13) will then be a function of η alone; we shall now proceed to determine that function.

Since

$$z_{xx} = z_{\xi\xi}\xi_x^2 + 2z_{\xi\eta}\xi_x\eta_x + z_{\eta\eta}\eta_x^2 + z_{\xi\xi}z_{xx} + z_{\eta\eta}z_{xx}$$

and since z_ξ and z_η are continuous (a result of the continuity of z_x and z_y) and $z_{\xi\eta}$ and $z_{\eta\eta}$ are tangential derivatives, we find that $[z_{xx}]$, which by definition is equal to

$$\lim_{P_1, P_2 \rightarrow P_0} \{z_{xx}(P_2) - z_{xx}(P_1)\}$$

reduces to

$$\lim_{P_1, P_2 \rightarrow P_0} \{z_{\xi\xi}(P_2)\xi_x^2(P_2) - z_{\xi\xi}(P_1)\xi_x^2(P_1)\}$$

so that
$$[z_{xx}] = [z_{\xi\xi}]\xi_x^2(P_0) \tag{14}$$

A comparison of equation (14) with the equations (13) shows that the value of the quantity λ occurring in these equations is $[z_{\xi\xi}]$. We began by assuming that there was a discontinuity in at least one of the second derivatives; so λ cannot be zero, and hence neither can $[z_{\xi\xi}]$ at the point P_0 .

If we transform the equation to the new variables ξ and η , we get the equation (4) of Sec. 5, and applying the above argument to it, we see that

$$[z_{\xi\xi}]A(\xi_x, \xi_y) = 0$$

showing that

$$A(\xi_x, \xi_y) = 0 \tag{15}$$

and thereby proving that the curve C is a characteristic of the equation. If we differentiate the transformed equation with regard to ξ , take equation (15) into account, and note that only the terms in $z_{\xi\xi}$ and $z_{\xi\eta}$ can be discontinuous, we can use a similar argument to show that

$$2B(\xi_x, \xi_y; \eta_x, \eta_y)[z_{\xi\eta}] + \{A_\xi(\xi_x, \xi_y) - F_\xi\}[z_{\xi\xi}] = 0$$

Remembering that $[z_z]$ is λ and that λ is a function of η alone, we see that this last equation is equivalent to the ordinary differential equation

$$\frac{d\lambda}{d\eta} = \lambda g(\eta)$$

which has a solution of the form

$$\lambda(\eta) = \lambda(\eta_0) \exp \left\{ \int_{\eta_0}^{\eta} g(\xi) d\xi \right\}$$

So far we have considered only single characteristic curves; now let us consider briefly all the characteristic curves on an integral surface Σ of the differential equation (1). If the equation is hyperbolic at all points of the surface, there are two one-parameter families of characteristic curves on Σ . It follows that two integral surfaces can touch only along a characteristic, for if the line of contact were not a characteristic, it would define unique values of all partial derivatives along its length and would therefore yield one surface, not the postulated two. Along a characteristic curve, on the other hand, this contradiction does not occur. In the case of elliptic equations, for which there are no real characteristics, the corresponding result would be that two integral surfaces cannot touch along any line.

PROBLEMS

1. Show that the characteristics of the equation

$$Rr + Ss + Tt = f(x, y, z, p, q)$$

are invariant with respect to any transformations of the independent variables.

2. Show that the characteristics of the second-order equation

$$A \frac{\partial^2 z}{\partial x^2} + 2B \frac{\partial^2 z}{\partial x \partial y} + C \frac{\partial^2 z}{\partial y^2} = F(x, y, z, p, q)$$

are the same as the projections on the xy plane of the Cauchy characteristics of the first-order equation

$$Ap^2 + 2Bpq + Cq^2 = 0$$

3. In the one-dimensional unsteady flow of a compressible fluid the velocity u and the density ρ satisfy the equations

$$\frac{\partial u}{\partial t} + u \frac{\partial u}{\partial x} - \frac{1}{\rho} \frac{\partial \rho}{\partial x} = 0, \quad \frac{\partial \rho}{\partial t} + u \frac{\partial \rho}{\partial x} + \rho \frac{\partial u}{\partial x} = 0$$

If the law connecting the pressure p with the density ρ is $p = k\rho^2$, show that

$$\frac{\partial u}{\partial t} + u \frac{\partial u}{\partial x} - 2c \frac{\partial c}{\partial x} = 0, \quad 2 \frac{\partial c}{\partial t} + 2u \frac{\partial c}{\partial x} - c \frac{\partial u}{\partial x} = 0$$

where $c^2 = dp/d\rho$. Prove that the characteristics are given by the differential equations $dx = (u - c) dt$ and that on the characteristics $u - 2c$ are constant.

If there is a family of straight characteristics $x = mt$ satisfying the differential equation $dx/dt = u - c$, prove that

$$u = \frac{2x}{3t} + \mu, \quad c = \frac{x}{3t} + \mu$$

where μ is a constant. Determine the equations of the other family of characteristics.

4. In two-dimensional steady flow of compressible fluid the velocity (u, v) and the density ρ satisfy the equations

$$\rho u \frac{\partial u}{\partial x} - \rho v \frac{\partial u}{\partial y} - c^2 \frac{\partial \rho}{\partial x} = 0$$

$$\rho u \frac{\partial v}{\partial x} - \rho v \frac{\partial v}{\partial y} - c^2 \frac{\partial \rho}{\partial y} = 0$$

$$\frac{\partial}{\partial x} (u\rho) - \frac{\partial}{\partial y} (v\rho) = 0$$

where $c^2 = dp/d\rho$. Show that the condition that the curve $\xi(x, y) = \text{constant}$ should be a characteristic, i.e., such that u_ξ, v_ξ, ρ_ξ are *not* uniquely determined along it, is that

$$(u\xi_x + v\xi_y)(u\xi_x - v\xi_y)^2 - c^2(\xi_x^2 + \xi_y^2) = 0$$

Show that the second factor has real linear factors if, and only if, $u^2 + v^2 \geq c^2$. Interpret these results physically.

5. Characteristics of Equations in Three Variables

The concept of the characteristic curves of a second-order linear differential equation which was developed in the last section for equations in two independent variables may readily be extended to the case where there are n independent variables. In this section we shall show how the analysis may be extended in the case $n = 3$. The general result proceeds along similar lines, but the geometrical concepts are more easily visualized in the case we shall consider.

We suppose that we have three independent variables x_1, x_2, x_3 and one dependent variable u , and we write p_{ij} for $\partial^2 u / \partial x_i \partial x_j$, p_i for $\partial u / \partial x_i$. The problem we consider is that of finding a solution of the linear equation

$$L(u) = \sum_{i,j=1}^3 a_{ij} p_{ij} + \sum_{i=1}^3 b_i p_i + cu = 0 \tag{1}$$

in which u and $\partial u / \partial n$ take on prescribed values on the surface S whose equation is

$$f(x_1, x_2, x_3) = 0 \tag{2}$$

we suppose that the freedom equations of S are

$$x_i = \bar{x}_i(\tau_1, \tau_2) \quad i = 1, 2, 3 \tag{3}$$

then we may write the boundary conditions in the form

$$\bar{u} = F(\tau_1, \tau_2), \quad \overline{\partial u / \partial n} = G(\tau_1, \tau_2) \quad (4)$$

the bar denoting that these are the values assumed by the relevant quantity on the surface S .

From equation (2) we have the identity

$$\sum_{i=1}^3 \frac{\partial f}{\partial x_i} \left(\frac{\partial x_i}{\partial \tau_1} d\tau_1 + \frac{\partial x_i}{\partial \tau_2} d\tau_2 \right) = 0$$

so that equating to zero the coefficients of $d\tau_1$ and $d\tau_2$, we have

$$\sum_{i=1}^3 \delta_i P_{ij} = 0 \quad j = 1, 2 \quad (5)$$

where $\delta_i = \partial f / \partial x_i$, $P_{ij} = \partial x_i / \partial \tau_j$. Solving these equations, we find that

$$\frac{\delta_1}{\Delta_1} = \frac{\delta_2}{\Delta_2} = \frac{\delta_3}{\Delta_3} = \rho, \text{ say} \quad (6)$$

where Δ_1 denotes the Jacobian $\partial(x_2, x_3) / \partial(\tau_1, \tau_2)$ and the others are defined similarly.

Taking the total derivative of \bar{u} , we find in a similar way that

$$d\bar{u} = \sum_{i=1}^3 \sum_{j=1}^2 \rho_i P_{ij} d\tau_j$$

from which it follows that the first of the conditions (4) is equivalent to

$$\sum_{i=1}^3 \rho_i P_{ij} = \frac{\partial F}{\partial \tau_j} \quad j = 1, 2 \quad (7)$$

The second condition gives

$$\sum_{i=1}^3 \rho_i \delta_i = G(\delta_1^2 + \delta_2^2 + \delta_3^2)^{\frac{1}{2}} \quad (8)$$

Equations (7) and (8) are sufficient for the determination of ρ_1, ρ_2, ρ_3 at all points of the surface S , it being easily verified that the determinant of their coefficients does not vanish.

We can determine the second derivatives of u at points of S by applying the same procedure to \bar{p}_i (the value of p_i on S) as we have just applied to \bar{u} . We obtain the pair of equations

$$\sum_{r=1}^3 P_{rj} p_{ir} = \frac{\partial \bar{p}_i}{\partial \tau_j} \quad j = 1, 2 \quad (9)$$

for each value of i . This pair of equations is not sufficient for the solution of p_{i1}, p_{i2}, p_{i3} , so that we add the equation

$$\sum_{r=1}^3 \alpha_r p_{ir} = \lambda_i \quad (10)$$

where λ_i is a parameter in terms of which all the p_{ir} are expressed

linearly and the α 's are numerical constants chosen in such a way as to ensure that the determinant

$$\Delta = \begin{vmatrix} P_{11} & P_{21} & P_{31} \\ P_{12} & P_{22} & P_{32} \\ \alpha_1 & \alpha_2 & \alpha_3 \end{vmatrix} \tag{11}$$

is nonzero.

Suppose now that the quantities p'_{ir} constitute a set of solutions of the equations (9); then

$$\sum_{r=1}^3 P_{ir}(p_{ir} - p'_{ir}) = 0 \quad j = 1, 2$$

so that
$$\frac{p_{i1} - p'_{i1}}{\Delta_1} = \frac{p_{i2} - p'_{i2}}{\Delta_2} = \frac{p_{i3} - p'_{i3}}{\Delta_3}$$

which can be written in the form

$$p_{ij} - p'_{ij} = \rho_i \Delta_j \tag{12}$$

where the ρ_i are constants. Now $p_{ij} = p_{ji}$ and $p'_{ij} = p'_{ji}$, so that we must have

$$\rho_i \Delta_j = \rho_j \Delta_i \tag{13}$$

But $\rho_i/\rho_j = \Delta_i/\Delta_j = \delta_i/\delta_j$, so that $\rho_i = \mu \delta_i$, where μ is a constant, and from (6) $\Delta_j = \delta_j/\rho$. Therefore $\rho_i \Delta_j = \lambda \delta_i \delta_j$, where $\lambda = \mu/\rho$ is a constant.

Hence we find

$$p_{ij} = p'_{ij} + \lambda \delta_i \delta_j$$

the value of λ being given by

$$\lambda \sum_{i,j=1}^3 a_{ij} \delta_i \delta_j + \sum_{i,j=1}^3 a_{ij} p'_{ij} + \sum_{i=1}^3 b_i p_i + cu = 0 \tag{14}$$

as found by substituting in the differential equation (1). This equation has a solution for λ unless the characteristic function

$$\Phi = \sum_{i,j}^3 a_{ij} \delta_i \delta_j \tag{15}$$

vanishes, i.e., unless f is such that

$$\sum_{i,j}^3 a_{ij} \frac{\partial f}{\partial x_i} \frac{\partial f}{\partial x_j} = 0 \tag{16}$$

When $\Phi \neq 0$, we can solve equation (14) for λ , so that then all the second derivatives can be found and the procedure repeated for higher derivatives of u on S . The complete solution can then be found by a Taylor expansion.

The equation (16), i.e., $\Phi = 0$, defines the *characteristic surfaces*. If $f(x_1, x_2, x_3)$ is a solution of (16), then the direction ratios $(\delta_1, \delta_2, \delta_3)$ of the normal at any point of the surface satisfy

$$\sum_{i,j}^3 a_{ij} \delta_i \delta_j = 0 \tag{17}$$

which is the equation of a cone. Therefore at any point in space the normals to all possible characteristic surfaces through the point lie on a cone. The planes perpendicular to these normals therefore also envelop a cone;¹ this cone is called the *characteristic cone* through the point. The characteristic cone at a point therefore touches all the characteristic surfaces at the point.

Now according to equations (8) of Sec. 13 of Chap. 2, the Cauchy characteristics of the first-order equation (16) are defined by the equations

$$\frac{dx_i}{\partial\Phi/\partial\delta_i} = \frac{d\delta_i}{\partial\Phi/\partial x_i} \quad i = 1, 2, 3$$

The integrals of these equations satisfying the correct initial conditions at a given point represent lines which are called the *bicharacteristics* of the equation (1). These lines in turn generate a surface, called a *conoid*, which reduces, in the case of constant a_{ij} 's, to the characteristic cone.

We may use the quadratic form (15) to classify second-order equations in three independent variables:

(a) If Φ is positive definite in the δ 's at the point $P(x_1^0, x_2^0, x_3^0)$, the characteristic cones and conoids are imaginary, and we say that the equation is *elliptic* at P .

(b) If Φ is indefinite, the characteristic cones are real, and we say that the equation is *hyperbolic* at the point.

(c) If the determinant

$$\begin{vmatrix} a_{11} & a_{21} & a_{31} \\ a_{12} & a_{22} & a_{32} \\ a_{13} & a_{23} & a_{33} \end{vmatrix}$$

of the form Φ vanishes, we say that the equation is *parabolic*.

This classification is in line with the one put forward in Sec. 5 for equations in two variables and has the advantage that it is readily generalized to equations in n variables.

PROBLEMS

1. Classify the equations:

(a) $u_{xx} + u_{yy} - u_z$

(b) $u_{xx} + u_{yy} + u_z$

(c) $u_{xx} + u_{yy} + u_z = 0$

(d) $u_{xx} + 2u_{yy} + u_z + 2u_{yz} + 2u_{zz}$

(e) $u_{xx} + u_{yy} + u_z + 2u_{yz} = 0$

¹ In solid geometry this second cone is called the *reciprocal cone* of the first. See, for example, R. J. T. Bell, "An Elementary Treatise on Coordinate Geometry of Three Dimensions," 2d ed. (Macmillan, London, 1931), p. 92.

2. Determine the characteristic surfaces of the wave equation

$$u_{xx} + u_{yy} - u_{zz} = 0$$

Show that the bicharacteristics are straight lines, and verify that they generate the characteristic cone.

3. The Solution of Linear Hyperbolic Equations

Before describing Riemann's method of solution of linear hyperbolic equations of the second order in two independent variables, we shall briefly sketch the existence theorems for two types of initial conditions in the equation

$$\frac{\partial^2 z}{\partial x \partial y} = f(x, y, z, z_x, z_y),$$

which, as we have seen, includes the most general linear hyperbolic equation. In the first kind of initial condition the integral surface is defined by two characteristics, one of each of the two families of characteristics on the surface; in the second kind (which corresponds to Cauchy's problem) the integral surface is defined by one space curve which nowhere touches a characteristic curve, p and q being prescribed along this curve.

For both kinds of initial condition it is assumed that the function $f(x, y, z, p, q)$ is continuous at all points of a region R defined by $x < x_1$, $\gamma < y < \delta$ for all values of x, y, z, p, q concerned and that it satisfies a Lipschitz condition

$$|f(x, y, z_2, p_2, q_2) - f(x, y, z_1, p_1, q_1)| \leq M \{ |z_2 - z_1| + |p_2 - p_1| + |q_2 - q_1| \}$$

in all bounded subrectangles r of R .

Initial Conditions of the First Kind. If $\sigma(x)$ and $\tau(y)$ are defined in the open intervals (α, β) , (γ, δ) , respectively, and have continuous first derivatives, and if (ξ, η) is a point inside R such that $\sigma(\xi) = \tau(\eta)$, then the given differential equation has at least one integral $z = z(x, y)$ in R which takes the value $\sigma(x)$ on $y = \eta$ and the value $\tau(y)$ on $x = \xi$.

Initial Conditions of the Second Kind. If we are given (x, y, z, p, q) along a strip C_1 , i.e., we have $x = x(\lambda)$, etc., in terms of a single parameter λ , and if C_0 is the projection of this curve on the xy plane, then the given equation has an integral which takes on the given values of p, q along the curve C_0 . This integral exists at every point of the region R , which is defined as the smallest rectangle completely enclosing the curve C_0 .

For proofs of these results the reader is referred to D. Bernstein, "Existence Theorems in Partial Differential Equations," *Annals of Mathematics Studies*, no. 23 (Princeton, Princeton, N.J., 1950).

We shall now pass on to the problem of solving the general linear

hyperbolic equation of the second order. The method, due to Riemann, which we shall outline, represents the solution in a manner depending explicitly on the prescribed boundary conditions. Although this involves the solution of another boundary value problem for the Green's function (to be defined below), this often presents no great difficulty.

We shall assume that the equation has already been reduced to canonical form

$$L(z) = f(x, y) \quad (1)$$

where L denotes the linear operator

$$\frac{\partial^2}{\partial x \partial y} + a \frac{\partial}{\partial x} + b \frac{\partial}{\partial y} + c \quad (2)$$

Now let w be another function with continuous derivatives of the first order. Then we may write

$$w \frac{\partial^2 z}{\partial x \partial y} - z \frac{\partial^2 w}{\partial x \partial y} = \frac{\partial}{\partial y} \left(w \frac{\partial z}{\partial x} \right) - \frac{\partial}{\partial x} \left(z \frac{\partial w}{\partial y} \right)$$

$$wa \frac{\partial z}{\partial x} + z \frac{\partial (aw)}{\partial x} = \frac{\partial}{\partial x} (awz)$$

$$wb \frac{\partial z}{\partial y} + z \frac{\partial (bw)}{\partial y} = \frac{\partial}{\partial y} (bwz)$$

so that
$$wLz - zMw = \frac{\partial U}{\partial x} + \frac{\partial V}{\partial y} \quad (3)$$

where M is the operator defined by the relation

$$Mw = \frac{\partial^2 w}{\partial x \partial y} - \frac{\partial (aw)}{\partial x} - \frac{\partial (bw)}{\partial y} + cw \quad (4)$$

and
$$U = awz - z \frac{\partial w}{\partial y}, \quad V = bwz + w \frac{\partial z}{\partial x} \quad (5)$$

The operator M defined by equation (4) is called the adjoint operator to the operator L . If $M = L$, we say that the operator L is self-adjoint.

Now if Γ is a closed curve enclosing an area Σ , then it follows from equation (3) and a straightforward use of Green's theorem¹ that

$$\begin{aligned} \iint_{\Sigma} (wLz - zMw) dx dy &= \int_{\Gamma} (U dy - V dx) \\ &= \int_{\Gamma} \{U \cos(n, x) - V \cos(n, y)\} ds \end{aligned} \quad (6)$$

where n denotes the direction of the *inward-drawn* normal to the curve Γ .

¹ P. Franklin, "Methods of Advanced Calculus" (McGraw-Hill, New York, 1944), p. 201.

Suppose now that the values of z and $\partial z/\partial x$ or $\partial z/\partial y$ are prescribed along a curve C in the xy plane (cf. Fig. 20) and that we wish to find the solution of the equation (1) at the point $P(\xi, \eta)$ agreeing with these boundary conditions. Through P we draw PA parallel to the x axis and cutting the curve C in the point A and PB parallel to the y axis and meeting C in B . We then take the curve Γ to be the closed circuit $PABP$, and since $dx = 0$ on PB and $dy = 0$ on PA , we have immediately from equation (6)

$$\int_{\Sigma} (wLz - zMw) dx dy = \int_{AB} (U dy - V dx) = \int_{BP} U dy - \int_{PA} V dx$$

Now, integrating by parts, we find that

$$\int_{PA} V dx = [zw]_P^A \\ = \int_{PA} z \left(bw - \frac{\partial w}{\partial x} \right) dx$$

that we obtain the formula

$$[zw]_P = [zw]_A + \int_{PA} z \left(bw - \frac{\partial w}{\partial x} \right) dx \\ + \int_{BP} z \left(aw - \frac{\partial w}{\partial y} \right) dy \\ + \int_{AB} (U dy - V dx) + \iint_{\Sigma} (wLz - zMw) dx dy$$

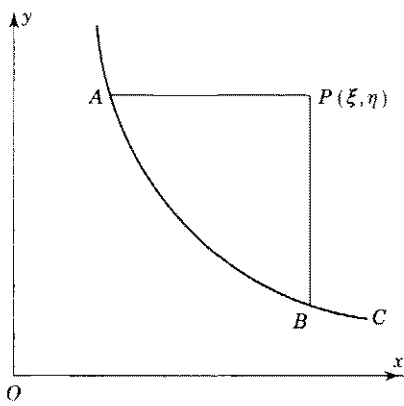

Figure 20

if the function w has been arbitrary. Suppose now that we choose a function $w(x, y; \xi, \eta)$ which has the properties

$$Mw = 0 \\ \frac{\partial w}{\partial x} = b(x, y)w \quad \text{when } y = \eta \\ \frac{\partial w}{\partial y} = a(x, y)w \quad \text{when } x = \xi \\ w = 1 \quad \text{when } x = \xi, y = \eta$$

such a function is called a *Green's function* for the problem or sometimes a *Schwarz-Green function*. Since also $Lz = f$, we find that

$$[zw]_A = \int_{AB} wz(a dy - b dx) + \iint_{\Sigma} \left(z \frac{\partial w}{\partial y} dy + w \frac{\partial z}{\partial x} dx \right) \\ = \iint_{\Sigma} (wf) dx dy \quad (7)$$

which enables us to find the value of z at the point P when $\partial z/\partial x$ is prescribed along the curve C . When $\partial z/\partial y$ is prescribed, we make use of the following calculation

$$[zw]_B - [zw]_A = \int_{AB} \left\{ \frac{\partial(zw)}{\partial x} dx + \frac{\partial(zw)}{\partial y} dy \right\}$$

to show that we can write equation (7) in the form

$$[z]_P = [zw]_B - \int_{AB} wz(a dy - b dx) - \int_{AB} \left\{ z \frac{\partial w}{\partial x} dx - w \frac{\partial z}{\partial y} dy \right\} + \iint_{\Sigma} (wf) dx dy \quad (8)$$

Finally, by adding equations (7) and (8), we obtain the symmetrical result

$$[z]_P = \frac{1}{2} \{ [zw]_A + [zw]_B \} - \int_{AB} wz(a dy - b dx) - \frac{1}{2} \int_{AB} w \left\{ \frac{\partial z}{\partial y} dy - \frac{\partial z}{\partial x} dx \right\} - \frac{1}{2} \int_{AB} z \left\{ \frac{\partial w}{\partial x} dx - \frac{\partial w}{\partial y} dy \right\} + \iint_{\Sigma} (wf) dx dy \quad (9)$$

By means of whichever of the formulas (7), (8), and (9) is appropriate we can obtain the solution of the given equation at any point in terms of the prescribed values of z , ρ , and q along a given curve C . We shall find that this method of Riemann's is of particular value in the discussion of the one-dimensional wave equation. A reader seeking a worked example is referred forward to that section (Sec. 3 of Chap. 5).

PROBLEMS

1. If L denotes the operator

$$R \frac{\partial^2}{\partial x^2} - S \frac{\partial^2}{\partial x \partial y} - T \frac{\partial^2}{\partial y^2} - P \frac{\partial}{\partial x} + Q \frac{\partial}{\partial y} - Z$$

and M is the adjoint operator defined by

$$Mw = \frac{\partial^2(Rw)}{\partial x^2} - \frac{\partial^2(Sw)}{\partial x \partial y} - \frac{\partial^2(Tw)}{\partial y^2} - \frac{\partial(Pw)}{\partial x} - \frac{\partial(Qw)}{\partial y} + Zw$$

show that¹

$$\iint_{\Sigma} (wLz - zMw) dx dy = \int_{\Gamma} \{ U \cos(n, x) - V \cos(n, y) \} ds$$

¹ This equation is known as the generalized form of Green's theorem.

where Γ is a closed curve enclosing an area Σ and

$$U = R w \frac{\partial z}{\partial x} - z \frac{\partial(R w)}{\partial x} - z \frac{\partial(S w)}{\partial y} + P z w,$$

$$V = S w \frac{\partial z}{\partial x} + T w \frac{\partial z}{\partial y} - z \frac{\partial(T w)}{\partial y} + Q z w$$

If $R_x + \frac{1}{2}S_y = P$, $\frac{1}{2}S_x + T_y = Q$, show that the operator L is self-adjoint.

- Determine the solution of the equation $s = f(x, y)$ which satisfies the boundary conditions z and q prescribed on a curve C .
- Obtain the solution, valid when $x, y > 0$, $xy > 1$, of the differential equation

$$\frac{\partial^2 z}{\partial x \partial y} = \frac{1}{x - y}$$

such that $z = 0$, $p = 2y/(x + y)$ on the hyperbola $xy = 1$.

- Prove that, for the equation

$$\frac{\partial^2 z}{\partial x \partial y} + \frac{1}{4}z = 0$$

the Green's function is

$$w(x, y; \xi, \eta) = J_0(\sqrt{(x - \xi)(y - \eta)})$$

where $J_0(z)$ denotes Bessel's function of the first kind of order zero.

- Prove that for the equation

$$\frac{\partial^2 z}{\partial x \partial y} + \frac{2}{x - y} \left(\frac{\partial z}{\partial x} + \frac{\partial z}{\partial y} \right) = 0$$

the Green's function is

$$w(x, y; \xi, \eta) = \frac{(x - y)\{2xy - (\xi - \eta)(x - y) + 2\xi\eta\}}{(\xi - \eta)^3}$$

Hence find the solution of the differential equation which satisfies the conditions $z = 0$, $\partial z / \partial x = 3x^2$ on $y = x$.

6. Separation of Variables

A powerful method of finding solutions of second-order linear partial differential equations is applicable in certain circumstances, when we assume a solution of the form

$$z = X(x)Y(y) \quad (1)$$

in the partial differential equation

$$Rr + Ss + Tt + Pp + Qq + Zz = F \quad (2)$$

is possible to write the equation (2) in the form

$$\frac{1}{X} f(D)X = \frac{1}{Y} g(D')Y \quad (3)$$

where $f(D)$, $g(D')$ are quadratic functions of $D = \partial/\partial x$ and $D' = \partial/\partial y$, respectively, we say that the equation (2) is separable in the variables x , y . The derivation of a solution of the equation is then immediate. For the left-hand side of (3) is a function of x alone, and the right-hand side is a function of y alone, and the two can be equal only if each is equal to a constant, λ say. The problem of finding solutions of the form (1) of the partial differential equation (2) therefore reduces to solving the pair of second-order linear ordinary differential equations

$$f(D)X = \lambda X, \quad g(D)Y = \lambda Y \quad (4)$$

The method is best illustrated by means of a particular example. Consider the one-dimensional diffusion equation

$$\frac{\partial^2 z}{\partial x^2} = \frac{1}{k} \frac{\partial z}{\partial t} \quad (5)$$

If we write

$$z = X(x)T(t)$$

we find that

$$\frac{1}{X} \frac{d^2 X}{dx^2} = \frac{1}{kT} \frac{dT}{dt}$$

so that the pair of ordinary equations corresponding to (4) is

$$\frac{d^2 X}{dx^2} = -\lambda X, \quad \frac{dT}{dt} = k\lambda T$$

so that if we are looking for a solution which tends to zero as $t \rightarrow \infty$, we may take

$$X = A \cos(nx - \epsilon), \quad T = Be^{-kn^2 t}$$

where we have written $-n^2$ for λ . Thus

$$z(x, t) = c_n \cos(nx - \epsilon_n) e^{-n^2 kt}$$

where c_n is a constant, is a solution of the partial differential (5) for all values of n . Hence expressions formed by summing over all values of n

$$z(x, t) = \sum_{n=0}^{\infty} c_n \cos(nx + \epsilon_n) e^{-n^2 kt} \quad (6)$$

are, formally at least, solutions of equation (5). It should be noted that the solutions (6) have the property that $z \rightarrow 0$ as $t \rightarrow \infty$ and that

$$z(x, 0) = \sum_{n=0}^{\infty} c_n \cos(nx + \epsilon_n) \quad (7)$$

The principle can readily be extended to a larger number of variables. For example, if we wish to find solutions of the form

$$z = X(x)Y(y)T(t) \quad (8)$$

of the equation

$$\frac{\partial^2 z}{\partial x^2} + \frac{\partial^2 z}{\partial y^2} = \frac{1}{k} \frac{\partial z}{\partial t} \quad (9)$$

we note that for such a solution equation (9) can be written as

$$\frac{1}{X} \frac{d^2 X}{dx^2} + \frac{1}{Y} \frac{d^2 Y}{dy^2} + \frac{1}{kT} \frac{dT}{dt}$$

so that we may take

$$\frac{dT}{dt} = -n^2 kT, \quad \frac{d^2 X}{dx^2} = l^2 X, \quad \frac{d^2 Y}{dy^2} = -m^2 Y$$

provided that

$$l^2 + m^2 = n^2$$

Hence we have solutions of equation (9) of the form

$$z(x, y, t) = \sum_{l=0}^{\infty} \sum_{m=0}^{\infty} c_{lm} \cos(lx + \epsilon_l) \cos(my + \epsilon_m) e^{-k(l^2 + m^2)t} \quad (10)$$

PROBLEMS

1. By separating the variables, show that the one-dimensional wave equation

$$\frac{\partial^2 z}{\partial x^2} = \frac{1}{c^2} \frac{\partial^2 z}{\partial t^2}$$

has solutions of the form $A \exp(i \cdot inx + imct)$, where A and n are constants. Hence show that functions of the form

$$z(x, t) = \sum_r \left\{ A_r \cos \frac{r\pi ct}{a} + B_r \sin \frac{r\pi ct}{a} \right\} \sin \frac{r\pi x}{a}$$

where the A_r 's and B_r 's are constants, satisfy the wave equation and the boundary conditions $z(0, t) = 0$, $z(a, t) = 0$ for all t .

2. By separating the variables, show that the equation $\nabla_1^2 V = 0$ has solutions of the form $A \exp(i \cdot inx + imy)$, where A and n are constants. Deduce that functions of the form

$$V(x, y) = \sum_r A_r e^{-r\pi x/a} \sin \frac{r\pi y}{a} \quad x > 0, 0 \leq y \leq a$$

where the A_r 's are constants, are plane harmonic functions satisfying the conditions $V(x, 0) = 0$, $V(x, a) = 0$, $V(x, y) \rightarrow 0$ as $x \rightarrow \infty$.

3. Show that if the two-dimensional harmonic equation $\nabla_1^2 V = 0$ is transformed to plane polar coordinates r and θ , defined by $x = r \cos \theta$, $y = r \sin \theta$ it takes the form

$$\frac{\partial^2 V}{\partial r^2} + \frac{1}{r} \frac{\partial V}{\partial r} + \frac{1}{r^2} \frac{\partial^2 V}{\partial \theta^2} = 0$$

and deduce that it has solutions of the form $(Ar^n + Br^{-n})e^{\pm in\theta}$, where A , B , and n are constants.

Determine V if it satisfies $\nabla_1^2 V = 0$ in the region $0 \leq r \leq a$, $0 \leq \theta \leq 2\pi$ and satisfies the conditions:

- (i) V remains finite as $r \rightarrow 0$;
 (ii) $V = \sum_r c_n \cos(n\theta)$ on $r = a$.

4. Show that in cylindrical coordinates ρ, z, ϕ Laplace's equation has solutions of the form $R(\rho)e^{imz + in\phi}$, where $R(\rho)$ is a solution of Bessel's equation

$$\frac{d^2 R}{d\rho^2} + \frac{1}{\rho} \frac{dR}{d\rho} + \left(m^2 - \frac{n^2}{\rho^2} \right) R = 0$$

If $R \rightarrow 0$ as $z \rightarrow \infty$ and is finite when $\rho = 0$, show that, in the usual notation for Bessel functions¹ the appropriate solutions are made up of terms of the form $J_n(m\rho)e^{-mz + in\phi}$.

5. Show that in spherical polar coordinates r, θ, ϕ Laplace's equation possesses solutions of the form

$$\left\{ Ar^n + \frac{B}{r^{n+1}} \right\} \Theta(\cos \theta) e^{ims}$$

where A, B, m , and n are constants and $\Theta(\mu)$ satisfies the ordinary differential equation

$$(1 - \mu^2) \frac{d^2 \Theta}{d\mu^2} - 2\mu \frac{d\Theta}{d\mu} + \left\{ n(n+1) - \frac{m^2}{1 - \mu^2} \right\} \Theta = 0$$

10. The Method of Integral Transforms

The use of the theory of integral transforms in the solution of partial differential equations may be simply explained by an example which possesses a fair degree of generality. Suppose we have to determine a function u which depends on the independent variables x_1, x_2, \dots, x_n and whose behavior is determined by the linear partial differential equation

$$a(x_1) \frac{\partial^2 u}{\partial x_1^2} + b(x_1) \frac{\partial u}{\partial x_1} + c(x_1)u + Lu = f(x_1, x_2, \dots, x_n) \quad (1)$$

in which L is a linear differential operator in the variables x_2, \dots, x_n and the range of variation of x_1 is $\alpha \leq x_1 \leq \beta$. If we let

$$\bar{u}(\xi, x_2, \dots, x_n) = \int_{\alpha}^{\beta} u(x_1, x_2, \dots, x_n) K(\xi, x_1) dx_1 \quad (2)$$

then an integration by parts shows that

$$\begin{aligned} & \int_{\alpha}^{\beta} \left\{ a(x_1) \frac{\partial^2 u}{\partial x_1^2} + b(x_1) \frac{\partial u}{\partial x_1} + c(x_1)u \right\} K(\xi, x_1) dx_1 \\ &= g(\xi, x_2, \dots, x_n) + \int_{\alpha}^{\beta} u \left\{ \frac{\partial^2}{\partial x_1^2} (aK) - \frac{\partial}{\partial x_1} (bK) + cK \right\} dx_1 \end{aligned}$$

where $g(\xi, x_2, \dots, x_n) = \left[a \frac{\partial u}{\partial x_1} K(\xi, x_1) + u \left\{ bK - \frac{\partial}{\partial x_1} (aK) \right\} \right]_{\alpha}^{\beta}$

If therefore we choose the function $K(\xi, x_1)$ so that

$$\frac{\partial^2}{\partial x_1^2} (aK) - \frac{\partial}{\partial x_1} (bK) + cK = \lambda K \quad (3)$$

¹ M. Golomb and M. E. Shanks, "Elements of Ordinary Differential Equations" (McGraw-Hill, New York, 1950), p. 298.

where λ is a constant, then multiplying equation (1) by $K(\xi, x_1)$ and integrating with respect to x_1 from α to β , we find that the function $\bar{u}(\xi, x_2, \dots, x_n)$, defined by equation (2), satisfies the equation

$$(L + \lambda)\bar{u}(\xi, x_2, \dots, x_n) = F(\xi, x_2, \dots, x_n) \tag{4}$$

where $F(\xi, x_2, \dots, x_n) = \bar{f}(\xi, x_2, \dots, x_n) - g(\xi, x_2, \dots, x_n)$, \bar{f} being defined by an equation of type (2).

We say that \bar{u} is the *integral transform* of u corresponding to the kernel $K(\xi, x_1)$. The effect of employing the integral transform defined by the equations (2) and (3) is therefore to reduce the partial differential equation (1) in n independent variables x_1, x_2, \dots, x_n to one in $n - 1$ independent variables x_2, \dots, x_n and a parameter ξ . By the successive use of integral transforms of this type the given partial differential equation may eventually be reduced to an ordinary differential equation, or even to an algebraic equation, which can be solved easily. We are, of course, left with the problem of solving integral equations of the type

$$\bar{u}(\xi, x_2, \dots, x_n) = \int_{\alpha}^{\beta} u(x_1, x_2, \dots, x_n) K(\xi, x_1) dx_1$$

if we are to derive the expression for $u(x_1, x_2, \dots, x_n)$ when that for $\bar{u}(\xi, x_2, \dots, x_n)$ has been determined. For certain kernels of frequent use in mathematical physics it is possible to find a solution of this equation in the form

$$u(x_1, x_2, \dots, x_n) = \int_{\alpha}^{\beta} \bar{u}(\xi, x_2, \dots, x_n) H(\xi, x_1) d\xi \tag{5}$$

A relation of this kind is known as an *inversion theorem*. The inversion theorems for the integral transforms most commonly used in mathematical physics are tabulated in Table I. These theorems are not, of course, true for *all* functions u , for it is obvious that some u 's would make the relevant integrals divergent. Proofs of these theorems for the classes of functions most frequently encountered in mathematical physics have been formulated by Sneddon;¹ those appropriate to other classes of functions have been given by Titchmarsh.²

The procedure to be followed in applying the theory of integral transforms to the solution of partial differential equations therefore consists of four stages:

- (a) The calculation of the function $\bar{f}(\xi, x_2, \dots, x_n)$ by simple integration;
- (b) The construction of the equation (4) for the transform \bar{u} ;
- (c) The solution of this equation;
- (d) The calculation of u from the expression for \bar{u} by means of the appropriate inversion theorem.

1. N. Sneddon, "Fourier Transforms" (McGraw-Hill, New York, 1951).

2. E. C. Titchmarsh, "The Theory of Fourier Integrals" (Oxford, London, 1937).

Table I. Inversion Theorems for Integral Transforms

Name of transform	(x, β)	$K(\xi, x)$	(γ, δ)	$H(\xi, x)$
Fourier	$(-\infty, \infty)$	$\frac{1}{\sqrt{2\pi}} e^{i\xi x}$	$(-\infty, \infty)$	$\frac{1}{\sqrt{2\pi}} e^{-i\xi x}$
Fourier cosine	$(0, \infty)$	$\sqrt{\frac{2}{\pi}} \cos(\xi x)$	$(0, \infty)$	$\sqrt{\frac{2}{\pi}} \cos(\xi x)$
Fourier sine	$(0, \infty)$	$\sqrt{\frac{2}{\pi}} \sin(\xi x)$	$(0, \infty)$	$\sqrt{\frac{2}{\pi}} \sin(\xi x)$
Laplace	$(0, \infty)$	$e^{-\xi x}, R(\xi) > c$	$(\gamma - i\infty, \gamma + i\infty)$	$\frac{1}{2\pi i} e^{\xi x}, \gamma > c$
Mellin	$(0, \infty)$	$x^{\xi-1}$	$(\gamma - i\infty, \gamma + i\infty)$	$\frac{1}{2\pi i} x^{-\xi}$
Hankel	$(0, \infty)$	$x J_\nu(\xi x), \nu \geq -\frac{1}{2}$	$(0, \infty)$	$\xi J_\nu(\xi x)$

To illustrate this procedure we shall consider:

Example 11. Derive the solution of the equation:

$$\frac{\partial^2 V}{\partial r^2} + \frac{1}{r} \frac{\partial V}{\partial r} + \frac{\partial^2 V}{\partial z^2} = 0$$

for the region $r \geq 0, z \geq 0$, satisfying the conditions:

- (i) $V \rightarrow 0$ as $z \rightarrow \infty$ and as $r \rightarrow \infty$
(ii) $V = f(r)$ on $z = 0, r \geq 0$

If we introduce the Hankel transform

$$\bar{V} = \int_0^\infty r V(r, z) J_0(\xi r) dr$$

then, integrating by parts and making use of (i), we find that

$$\int_0^\infty \left\{ \frac{\partial^2 V}{\partial r^2} + \frac{1}{r} \frac{\partial V}{\partial r} \right\} r J_0(\xi r) dr = -\xi^2 \bar{V}$$

because of the fact that $J_0(\xi r)$ is a solution of Bessel's differential equation

$$\frac{d^2 f}{dr^2} + \frac{1}{r} \frac{df}{dr} - \xi^2 f = 0$$

Hence the equation satisfied by the Hankel transform \bar{V} is

$$\frac{d^2 \bar{V}}{dz^2} - \xi^2 \bar{V} = 0$$

where, as a result of the boundary conditions, we know that $\bar{V} \rightarrow 0$ as $z \rightarrow \infty$ and

that $\bar{V} = \bar{f}(\xi)$ on $z = 0$, $\bar{f}(\xi)$ denoting the Hankel transform (of zero order) of $f(r)$. The appropriate solution of the equation for \bar{V} is therefore

$$\bar{V} = \bar{f}(\xi)e^{-\xi z}$$

From the inversion theorem for the Hankel transform (last row of Table 1) we know that

$$V(r, z) = \int_0^\infty \xi \bar{V}(\xi, z) J_0(\xi r) d\xi$$

so that the required solution is

$$V(r, z) = \int_0^\infty \xi f(\xi) e^{-\xi z} J_0(\xi r) d\xi$$

If the form of $f(r)$ is given explicitly, $\bar{f}(\xi)$ can be calculated so that $V(r, z)$ can be obtained as the result of a single integration.

The method of integral transforms can, of course, be applied to linear partial differential equations of order higher than the second, as is shown by the following example:

Example 12. Determine the solution of the equation

$$\frac{\partial^4 z}{\partial x^4} - \frac{\partial^2 z}{\partial y^2} = 0$$

- (i) $x < \infty, y \geq 0$ satisfying the conditions:
- (ii) z and its partial derivatives tend to zero as $x \rightarrow \pm \infty$;
- (iii) $z = f(x), \quad \partial z / \partial y = 0$ on $y = 0$.

In this case we may take

$$Z(\xi, y) = \frac{1}{\sqrt{2\pi}} \int_{-\infty}^{\infty} z(x, y) e^{i\xi x} dx$$

which, as a result of an integration by parts taking account of (i), we have

$$\frac{1}{\sqrt{2\pi}} \int_{-\infty}^{\infty} \frac{\partial^4 z}{\partial x^4} e^{i\xi x} dx = \xi^4 \bar{z}$$

that the equation determining the Fourier transform \bar{z} is

$$\frac{d^2 Z}{dy^2} + \xi^4 Z = 0$$

so $Z = F(\xi), dZ/dy = 0$ when $y = 0$. Therefore

$$Z = F(\xi) \cos(\xi^2 y)$$

the inversion theorem for Fourier transforms (first row of Table 1) we have

$$z(x, y) = \frac{1}{\sqrt{2\pi}} \int_{-\infty}^{\infty} Z(\xi, y) e^{-i\xi x} d\xi$$

so that finally

$$z(x, y) = \frac{1}{\sqrt{2\pi}} \int_{-\infty}^{\infty} F(\xi) \cos(\xi^2 y) e^{-i\xi x} d\xi$$

so $F(\xi)$ is the Fourier transform of $f(x)$.

PROBLEMS

1. The temperature θ in the semi-infinite rod $0 \leq x < \infty$ is determined by the differential equation

$$\frac{\partial \theta}{\partial t} = \kappa \frac{\partial^2 \theta}{\partial x^2}$$

and the conditions

(i) $\theta = 0$ when $t = 0, x \geq 0$

(ii) $\theta = \theta_0 = \text{const.}$ when $x = 0$ and $t > 0$

Making use of sine transform, show that

$$\theta(x, t) = \frac{2}{\pi} \theta_0 \int_0^\infty \frac{\sin(\xi x)}{\xi} (1 - e^{-\kappa \xi^2 t}) d\xi$$

2. If in the last question the condition (ii) is replaced by (ii') $\partial \theta / \partial x = -\mu$, a constant, when $x = 0$ and $t > 0$, prove that

$$\theta(x, t) = \frac{2\mu}{\pi} \int_0^\infty \frac{\cos(\xi x)}{\xi^2} (1 - e^{-\kappa \xi^2 t}) d\xi$$

3. Show that the solution of the equation

$$\frac{\partial z}{\partial x} = \frac{\partial^2 z}{\partial y^2}$$

which tends to zero as $y \rightarrow \infty$ and which satisfies the conditions

(i) $z = f(x)$ when $y = 0, x > 0$

(ii) $z = 0$ when $y > 0, x = 0$

may be written in the form

$$\frac{1}{2\pi i} \int_{\gamma-i\infty}^{\gamma+i\infty} f(\xi) e^{\xi x - y\sqrt{\xi}} d\xi$$

Evaluate this integral when $f(x)$ is a constant k .

4. The function $V(r, \theta)$ satisfies the differential equation

$$\frac{\partial^2 V}{\partial r^2} + \frac{1}{r} \frac{\partial V}{\partial r} + \frac{1}{r^2} \frac{\partial^2 V}{\partial \theta^2} = 0$$

in the wedge-shaped region $r \geq 0, |\theta| \leq \alpha$ and the boundary conditions $V = f(r)$ when $\theta = \pm \alpha$. Show that it can be expressed in the form

$$V(r, \theta) = \frac{1}{2\pi i} \int_{\gamma-i\infty}^{\gamma+i\infty} \frac{\cos(\xi \theta)}{\cos(\xi \alpha)} f(\xi) r^{-\xi} d\xi$$

where

$$f(\xi) = \int_0^\infty f(r) r^{\xi-1} dr$$

5. The variation of the function z over the xy plane and for $t \geq 0$ is determined by the equation

$$\nabla_1^2 z = \frac{1}{c^2} \frac{\partial^2 z}{\partial t^2}$$

If, when $t = 0$, $z = f(x, y)$ and $\partial z / \partial t = 0$, show that, at any subsequent time,

$$z(x, y) = \frac{1}{2\pi} \int_{-\pi}^{\pi} \int_{-\pi}^{\pi} F(\xi, \eta) \cos(\xi x + \eta y - \sqrt{\xi^2 + \eta^2} z) e^{-\alpha z - \beta \omega} d\xi d\eta$$

where
$$F(\xi, \eta) = \frac{1}{2\pi} \int_{-\pi}^{\pi} \int_{-\pi}^{\pi} f(x, y) e^{-\alpha x - \beta \omega} dx dy$$

11. Nonlinear Equations of the Second Order

It is only in special cases that a partial differential equation

$$F(x, y, z, p, q, r, s, t) = 0 \tag{1}$$

of the second order can be integrated. The most important method of solution, due to Monge, is applicable to a wide class of such equations but by no means to them all. Monge's method consists in establishing one or two *first integrals* of the form

$$\eta = f(\xi) \tag{2}$$

where ξ and η are known functions of $x, y, z, p,$ and q and the function f is arbitrary, i.e., in finding relations of the type (2) such that equation (1) can be derived from equation (2) and the relations

$$\eta_x = \eta_z p + \eta_r r - \eta_s s = f'(\xi) \{ \xi_x + \xi_z p + \xi_r r + \xi_s s \} \tag{3}$$

$$\eta_y = \eta_z q + \eta_t t = f'(\xi) \{ \xi_y + \xi_z q + \xi_t t \} \tag{4}$$

obtained from it by partial differentiation.

It should be noted at the outset that not every equation (1) has a first integral of the type (2). In fact by eliminating $f'(\xi)$ from equations (3) and (4), we see that any second-order partial differential equation which possesses a first integral of the type (2) must be expressible in the form

$$R_1 r + S_1 s - T_1 t + U_1 (rt - s^2) = V_1 \tag{5}$$

where $R_1, S_1, T_1, U_1,$ and V_1 are functions of $x, y, z, p,$ and q defined by the relations

$$R_1 = \frac{\partial(\xi, \eta)}{\partial(p, y)} + q \frac{\partial(\xi, \eta)}{\partial(p, z)}, \quad T_1 = \frac{\partial(\xi, \eta)}{\partial(x, q)} + p \frac{\partial(\xi, \eta)}{\partial(z, q)} \tag{6a}$$

$$S_1 = \frac{\partial(\xi, \eta)}{\partial(q, y)} + q \frac{\partial(\xi, \eta)}{\partial(q, z)} - \frac{\partial(\xi, \eta)}{\partial(p, x)} - p \frac{\partial(\xi, \eta)}{\partial(p, z)} \tag{6b}$$

$$U_1 = \frac{\partial(\xi, \eta)}{\partial(p, q)}, \quad V_1 = q \frac{\partial(\xi, \eta)}{\partial(z, x)} + p \frac{\partial(\xi, \eta)}{\partial(y, z)} + \frac{\partial(\xi, \eta)}{\partial(y, x)} \tag{6c}$$

The equation (5) therefore reduces to the form

$$R_1 r + S_1 s + T_1 t = V_1 \tag{7}$$

if and only if the Jacobian $\xi_y \eta_x - \xi_x \eta_y$ vanishes identically. An

equation of the type (7) is nonlinear, since the coefficients R_1, S_1, T_1, V_1 are functions of p and q as well as of $x, y,$ and z . It has a certain formal resemblance to a linear equation, and for that reason is often referred to as a *quasi-linear* equation; it is also called a *uniform* nonlinear equation. An equation of the type (5) is, by contrast, known as a nonuniform equation.

We shall assume that a first integral of the equation

$$Rx + Sz - Tt - U(rt - s^2) = V \quad (8)$$

exists and that it is of the form (2). Our problem is, having postulated its existence, to establish a procedure for finding this first integral.

For any function z of x and y we have the relations

$$dp = r dx + s dy, \quad dq = s dx + t dy \quad (9)$$

so that eliminating r and t from this pair of equations and equation (8), we see that any solution of (8) must satisfy the relation

$$R dp dy + T dq dx - U dp dq - V dx dy = s(R dy^2 + S dx dy + T dx^2 + U dp dx + U dq dy) \quad (10)$$

If we suppose that

$$\xi(x, y, z, p, q) = c_1, \quad \eta(x, y, z, p, q) = c_2$$

are two integrals of the set of equations

$$R dp dy + T dq dx + U dp dq - V dx dy = 0 \quad (11)$$

$$R dy^2 + T dx^2 + U dp dx + U dq dy - S dx dy \quad (12)$$

$$dz = p dx + q dy \quad (13)$$

then the equations

$$d\xi = 0, \quad d\eta = 0 \quad (14)$$

are equivalent to the set (11) to (13). Eliminating dz from equations (13) and (14), we get the pair

$$dp = -\frac{T_1}{U_1} dx - \frac{1}{U_1} \left(\frac{\partial(\xi, \eta)}{\partial(y, q)} + \frac{\partial(\xi, \eta)}{\partial(z, q)} q \right) dy \quad (15)$$

$$dq = -\frac{1}{U_1} \left(\frac{\partial(\xi, \eta)}{\partial(x, p)} + \frac{\partial(\xi, \eta)}{\partial(z, p)} p \right) dx - \frac{R_1}{U_1} dy \quad (16)$$

where R_1, T_1, U_1 are defined by the equations (6). Substituting for dp, dq from these equations, we see that

$$dp dx + dq dy = -\frac{T_1}{U_1} dx^2 - \frac{R_1}{U_1} dy^2 + \frac{1}{U_1} \left(\frac{\partial(\xi, \eta)}{\partial(q, y)} + \frac{\partial(\xi, \eta)}{\partial(q, z)} q - \frac{\partial(\xi, \eta)}{\partial(p, x)} - \frac{\partial(\xi, \eta)}{\partial(p, z)} p \right) dx dy$$

a relation which is equivalent to the equation

$$R_1 dy^2 \div T_1 dx^2 \div U_1 dp dx \div U_1 dq dy = S_1 dx dy \tag{17}$$

Similarly we can show that

$$R_1 dp dy \div T_1 dq dx \div U_1 dp dq = V_1 dx dy = 0 \tag{18}$$

Comparing equations (17) and (18) with (11) and (12), we see that

$$\frac{R_1}{R} = \frac{S_1}{S} = \frac{T_1}{T} = \frac{U_1}{U} = \frac{V_1}{V} \tag{19}$$

so that the equation (8), which we have to solve, is equivalent to the equation (5), which we know has a first integral of the form (2). The first integral (2) is therefore derived by making one of the functions η obtained from a solution $\eta = c_2$ of the equations (11) to (13) a function of a second solution ξ . The procedure of determining a first integral of the equation (8) thus reduces to that of solving this set of equations.

In many cases it is possible to derive solutions of these equations by inspection, but when this cannot be done, the following procedure may be adopted. From equations (11) and (12) we obtain the single equation

$$R dy^2 - (S \div \lambda V) dx dy \div T dx^2 \div U dp dx \div U dq dy \div \lambda R dp dy \div \lambda T dq dx \div \lambda U dp dq = 0$$

where λ is (for the moment) an undetermined multiplier, and it is readily shown that this equation can be written in the form

$$(U dy + \lambda T dx + \lambda U dp)(\lambda R dy \div U dx + \lambda U dq) = 0 \tag{20}$$

provided that λ is chosen to be a root of the quadratic equation

$$\lambda^2(RT + UV) \div \lambda US \div U^2 = 0 \tag{21}$$

Apart from the special case when $S^2 = 4(RT \div UV)$, this equation will have two distinct roots λ_1, λ_2 , and the problem of solving equations (11) and (12) will reduce to the solution of the pairs

$$U dy \div \lambda_1 T dx \div \lambda_1 U dp = 0, \quad \lambda_2 R dy \div U dx \div \lambda_2 U dq = 0 \tag{22}$$

and

$$U dy \div \lambda_2 T dx \div \lambda_2 U dp = 0, \quad \lambda_1 R dy \div U dx \div \lambda_1 U dq = 0 \tag{23}$$

From each of these pairs we shall derive two integrals of the form $\xi(x, y, z, p, q) = c_1, \eta(x, y, z, p, q) = c_2$ and hence two first integrals

$$\eta_1 = f_1(\xi_1), \quad \eta_2 = f_2(\xi_2)$$

which can often be solved to determine p and q as functions of x, y , and z . When we substitute these values into the equation

$$dz = p dx + q dy$$

it is found¹ that this equation is integrable. The integral of this equation, involving two arbitrary functions, will then be the solution of the original equation.

When it is possible to find only one first integral $\eta = f(\xi)$, we obtain the final integral by the use of Charpit's method (Sec. 10 of Chap. 2).

Example 13. Solve the equation

$$r + 4s + t + pt - s^2 = 2$$

For this equation we have, in the above notation, $R = 1$, $S = 4$, $T = 1$, $U = 1$, $V = 2$, so that equation (21) becomes

$$3\lambda^2 + 4\lambda + 1 = 0$$

with roots $\lambda_1 = -\frac{1}{3}$, $\lambda_2 = -1$. Hence equations (22) become

$$3dy - dx - dp = 0, \quad dy - dx + dq = 0$$

leading to the first integral

$$3y - x - p = f(y - x + q) \quad (24)$$

where the function f is arbitrary. Similarly equations (23) reduce to

$$dy - dx - dp = 0, \quad dy - 3dx + dq = 0$$

and yield the first integral

$$y - 3x + q = g(y - x - p) \quad (25)$$

the function g being arbitrary.

It is not possible to solve equations (24) and (25) for p and q ; so we combine the general integral (24) with any particular integral of (25), e.g.,

$$y - 3x + q = c_1 \quad (26)$$

where c_1 is a constant. Solving equations (24) and (26), we find that

$$q = c_1 + 3x - y, \quad p = 3y - x - f(2x + c_1)$$

from which it follows that

$$dz = \{3y - x - f(2x + c_1)\} dx + \{c_1 + 3x - y\} dy \quad (27)$$

and hence that

$$z = 3xy - \frac{1}{2}(x^2 + y^2) + F(2x + c_1) + c_1y - c_2 \quad (28)$$

where c_2 is an arbitrary constant. Equation (28) gives the complete integral. To obtain the general integral we replace c_1 by c , c_2 by $G(c)$, where the function G is arbitrary, and the required integral is then obtained by eliminating c between the equations

$$\begin{aligned} z &= 3xy - \frac{1}{2}(x^2 + y^2) + F(2x + c) - cy - G(c) \\ 0 &= F'(2x + c) - y - G'(c) \end{aligned}$$

It was mentioned above that in a great many cases it is possible to derive solutions of equations (11) and (12) directly. This is particularly

¹ For a proof that this equation is always integrable see A. R. Forsyth, "A Treatise on Differential Equations" (Macmillan, New York, 1885), pp. 365-368.

so in the case of uniform equations in which $U = 0$. For such equations the pair of equations (11) and (12) reduces to

$$R dp dy - T dq dx - V dx dy \tag{11'}$$

and
$$R dy^2 - S dx dy - T dx^2 = 0 \tag{12'}$$

We shall illustrate the solution of these equations by the particular example:

Example 14. Solve the equation $q^2r - 2pqs - p^2t = 0$.

In this case the equations (11') and (12') become

$$q^2 dp dy - p^2 dq dx = 0 \tag{i}$$

$$(p dx - q dy)^2 = 0 \tag{ii}$$

From equation (ii) and equation (13) we have $dz = 0$, which gives the integral $z = c_1$. From equations (i) and (ii) we have $q dp - p dq$, which has solution $p = c_2q$. We therefore have the first integral

$$p = qf(z)$$

where the function f is arbitrary. We can regard this as a linear equation of the first order and solve it by Lagrange's method. The auxiliary equations are

$$\frac{dx}{1} = \frac{dy}{-f(z)} = \frac{dz}{0}$$

with integrals $z = c_1, y - xf(c_1) = c_2$ leading to the general solution

$$y = xf(z) + g(z)$$

where the functions f and g are arbitrary.

PROBLEMS

1. Solve the wave equation $r = t$ by Monge's method.
2. Show that if a function z satisfies the differential equation

$$\frac{\partial^2 z}{\partial x^2} \frac{\partial z}{\partial y} = \frac{\partial^2 z}{\partial x} \frac{\partial z}{\partial y} \frac{\partial z}{\partial x}$$

it is of the form $f\{x + g(y)\}$, where the functions f and g are arbitrary.

3. Solve the equation

$$z(qs - pt) = pq^2$$

4. Solve the equation

$$pq = x(ps - qr)$$

5. Solve the equation

$$rq^2 - 2pqrs + tp^2 - pt - qs$$

6. Find an integral of the equation

$$z^2(rt - s^2) + z(1 - q^2)r - 2pqzs + z(1 + p^2)t + 1 + p^2 + q^2 = 0$$

involving three arbitrary constants.

Verify the result and indicate the method of proceeding to the general solution.

MISCELLANEOUS PROBLEMS

1. The equation $z^3 - 3xyz - a^3 = 0$ defines z implicitly as a function of x and y . Prove that

$$x^2 \frac{\partial^2 z}{\partial x^2} = y^2 \frac{\partial^2 z}{\partial y^2}$$

2. The variables x , y , and z are related through the equations

$$x = f(u) - v; \quad y = g(v) + u; \quad z = uv + uf'(u) - vg'(v) - f(u) - g(v)$$

Show that, whatever the form of the functions f and g ,

$$\frac{\partial^2 z}{\partial x^2} \frac{\partial^2 z}{\partial y^2} - \left(\frac{\partial^2 z}{\partial x \partial y} \right)^2 + \frac{\partial^2 z}{\partial x \partial y} = 0$$

3. In plane polar coordinates the equations of equilibrium of an elastic solid become

$$\frac{\partial \sigma_r}{\partial r} + \frac{1}{r} \frac{\partial \tau_{r\theta}}{\partial \theta} + \frac{\sigma_r - \sigma_\theta}{r} = 0, \quad \frac{\partial \tau_{r\theta}}{\partial r} - \frac{1}{r} \frac{\partial \sigma_\theta}{\partial \theta} - \frac{2\tau_{r\theta}}{r} = 0$$

Show that these equations possess a solution

$$\sigma_r = \frac{1}{r^2} \frac{\partial^2 \psi}{\partial \theta^2} + \frac{1}{r} \frac{\partial \psi}{\partial r}, \quad \sigma_\theta = \frac{\partial^2 \psi}{\partial r^2}, \quad \tau_{r\theta} = -\frac{\partial}{\partial r} \left(\frac{1}{r} \frac{\partial \psi}{\partial \theta} \right)$$

It can be shown that the compatibility conditions lead to $\nabla_1^4 \psi = 0$; verify that $\psi = (Ax + By)\theta$ is a solution of this equation, and calculate the corresponding components of stress.

4. In plane polar coordinates the Hencky-Mises condition is

$$(\sigma_r - \sigma_\theta)^2 + 4\tau_{r\theta}^2 = 4k^2$$

Show that the shearing stress $\tau_{r\theta}$ satisfies the equation

$$\frac{\partial^2 \tau_{r\theta}}{\partial r^2} + \frac{3}{r} \frac{\partial \tau_{r\theta}}{\partial r} - \frac{1}{r^2} \frac{\partial^2 \tau_{r\theta}}{\partial \theta^2} = -\frac{2}{r^2} \frac{\partial^2}{\partial r \partial \theta} \{r(k^2 - \tau_{r\theta}^2)\}$$

Determine the solution of this equation of the form $f(r)$ and satisfying the boundary conditions $\tau_{r\theta} = -k$ on $r = a$, $\tau_{r\theta} = k$ on $r = b$.

5. Find the general solution of the equation

$$xys - xp - yq + z = 0$$

and determine the solution of this equation which satisfies the conditions $z = x^n$ and $p = 0$ when $y = x$.

6. Solve the equation

$$(x - y)(x^2r - 2xys + y^2t) = 2xy(p - q)$$

7. Find the general solution of the equation

$$r + 4t = 8xy$$

Find also the particular solution for which $z = y^2$ and $p = 0$ when $x = 0$.

8. Show that the linear equation

$$s + ap + bq + cz + d = 0$$

may be reduced to a first-order equation if

$$\frac{\partial a}{\partial x} + ab - c = 0$$

Use this method to find the solution of the equation

$$s + pe^x - q = 0$$

9. Appell's first hypergeometric function of two variables is defined by the double power series

$$F_1(x; \beta, \beta'; \gamma; x, y) = \sum_{m=0}^{\infty} \sum_{n=0}^{\infty} \frac{(x)_{m+n} (\beta)_m (\beta')_n}{m! n! (\gamma)_{m+n}} x^m y^n$$

where $(\alpha)_r = \alpha(\alpha + 1) \cdots (\alpha + r - 1)$. Show that this function is a solution of the second-order linear partial differential equations

$$x(1-x)r + y(1-x)s + \{\gamma - (\alpha + \beta + 1)x\}p - \beta yq - \alpha \beta z = 0$$

$$y(1-y)t + x(1-y)s + \{\gamma - (\alpha + \beta' + 1)y\}q - \beta' xp - \alpha \beta' z = 0$$

Show also that Appell's second hypergeometric function

$$F_2(x; \beta, \beta'; \gamma, \gamma'; x, y) = \sum_{m=0}^{\infty} \sum_{n=0}^{\infty} \frac{(x)_{m+n} (\beta)_m (\beta')_n}{m! n! (\gamma)_m (\gamma')_n} x^m y^n$$

is a solution of the second-order equations

$$x(1-x)r - xys + \{\gamma - (x + \beta + 1)x\}p - \beta yq - \alpha \beta z = 0$$

$$y(1-y)t - xys + \{\gamma' - (\alpha + \beta' + 1)y\}q - \beta' xp - \alpha \beta' z = 0$$

10. Express the equation

$$\text{div}(\kappa \text{ grad } V) = 0$$

where κ and V are scalar point functions, in cylindrical coordinates ρ, ϕ, z . If $\kappa = \mu/\rho$, where μ is a constant, use the method of separation of variables to obtain a solution of the above equation independent of z and periodic in ϕ .

11. Show that the equation

$$\nabla^2 \psi = \frac{\partial^2 \psi}{\partial t^2}$$

has solutions of the form $\psi = S(\theta, \phi)R(r, t)$, where r, θ, ϕ are spherical polar coordinates and

$$\frac{1}{\sin \theta} \frac{\partial}{\partial \theta} \left(\sin \theta \frac{\partial S}{\partial \theta} \right) + \frac{1}{\sin^2 \theta} \frac{\partial^2 S}{\partial \phi^2} - n(n+1)S = 0$$

$$\frac{1}{r^2} \frac{\partial}{\partial r} \left(r^2 \frac{\partial R}{\partial r} \right) - \frac{n(n-1)}{r^2} R = \frac{\partial^2 R}{\partial t^2}$$

n being a constant integer. Verify that the last equation is satisfied by the function

$$R(r, t) = r^n \left(\frac{1}{r} \frac{\partial}{\partial r} \right)^n \left(\frac{f(r-t) + g(r+t)}{r} \right)$$

where the functions f and g are arbitrary.

12. Schrödinger's equation for the motion of an electron in a central field of potential $V(r)$ is, in atomic units,

$$\nabla^2 \psi + 2(W - V(r))\psi = 0$$

where W is a constant. By transforming this equation to polar coordinates r, θ, ϕ , show that it possesses solutions of the form

$$\psi = \frac{1}{r} R(r)S(\theta, \phi)$$

where $S(\theta, \phi)$ is defined in the same way as in the last problem and R is a solution of the ordinary differential equation

$$\frac{d^2 R}{dr^2} + 2(W - V(r) - \frac{1}{2}n(n+1))R = 0$$

13. Coordinates ξ and η are defined in terms of x and y by the equations

$$x = a \cosh \xi \cos \eta, \quad y = a \sinh \xi \sin \eta$$

and z is unaltered. Show that, in these coordinates, Laplace's equation $\nabla^2 V = 0$ takes the form

$$\frac{\partial^2 V}{\partial \xi^2} + \frac{\partial^2 V}{\partial \eta^2} + a^2(\cosh^2 \xi - \cos^2 \eta) \frac{\partial^2 V}{\partial z^2} = 0$$

and deduce that it has solutions of the form $f(i\xi)f(\eta)e^{-\gamma z}$, where γ is a constant, $f(x)$ is a solution of the ordinary differential equation

$$\frac{d^2 f}{dx^2} + (G + 16q \cos 2x)f = 0$$

G is a constant of separation, and $32q = -a^2\gamma^2$.

14. Show that if

$$x = \sqrt{\xi} \eta \cos \phi, \quad y = \sqrt{\xi} \eta \sin \phi, \quad z = \frac{1}{2}(\xi - \eta)$$

Laplace's equation assumes the form

$$\frac{\partial}{\partial \xi} \left(\xi \frac{\partial V}{\partial \xi} \right) + \frac{\partial}{\partial \eta} \left(\eta \frac{\partial V}{\partial \eta} \right) + \frac{\xi - \eta}{4\xi\eta} \frac{\partial^2 V}{\partial \phi^2} = 0$$

Deduce that it has solutions of the form $F_0(\xi)F_{-n}(\eta)e^{-im\phi}$, where $F_n(x)$ is a solution of the ordinary differential equation

$$x \frac{d^2 F}{dx^2} + \frac{dF}{dx} + \left(n + \frac{m^2}{4x} \right) F = 0$$

15. If $\bar{f}(\xi)$ and $\bar{g}(\xi)$ are the Fourier transforms of $f(x)$ and $g(x)$, respectively, prove that

$$\int_{-\infty}^{\infty} \bar{f}(\xi)\bar{g}(\xi)e^{-izx} d\xi = \int_{-\infty}^{\infty} g(u)f(x-u) du$$

16. If the function $z(x, y)$ is determined by the differential equation

$$\frac{\partial z}{\partial x} = \frac{\partial^2 z}{\partial y^2}$$

for $x \geq 0$, $-\infty < y < \infty$, and if $z = f(y)$ when $x = 0$, show that

$$z(x, y) = \frac{1}{\sqrt{2\pi}} \int_{-\infty}^{\infty} \bar{f}(\xi) e^{-\frac{1}{2}\xi^2 x - i\xi y} d\xi$$

where $\bar{f}(\xi)$ is the Fourier transform of $f(y)$.

Making use of the result obtained in the last problem, show that

$$z(x, y) = \frac{1}{\sqrt{4\pi x}} \int_{-\infty}^{\infty} f(u) e^{-y - u^2/4x} du$$

17. The function $\psi(x, y)$ is defined by the equations

$$(i) \nabla_1^2 \psi = f(x, y) \quad -\infty < x < \infty, y \geq 0$$

$$(ii) \frac{\partial \psi}{\partial y} = 0 \quad y = 0$$

Show that it can be expressed in the form

$$\frac{1}{\pi} \int_{-\infty}^{\infty} d\xi \int_{-\infty}^{\infty} \frac{F(\xi, \eta)}{(\xi^2 + \eta^2)^2} e^{-i\xi x} \cos(\eta y) d\eta$$

where

$$F(\xi, \eta) = \frac{1}{\pi} \int_{-\infty}^{\infty} dx \int_0^{\infty} f(x, y) e^{i\xi x} \cos(\eta y) dy$$

18. Show that the solution of the diffusion equation

$$\frac{\partial^2 \theta}{\partial x^2} = \frac{\partial \theta}{\partial t} \quad 0 \leq x \leq a, \quad t > 0$$

which satisfies the conditions

$$(i) \frac{\partial \theta}{\partial x} = 0 \quad \text{when } x = 0$$

$$(ii) \theta = \theta_0 = \text{const.} \quad \text{when } x = a$$

$$(iii) \theta = 0 \quad \text{when } t = 0, 0 \leq x \leq a$$

can be written in the form

$$\frac{\theta_0}{2\pi i} \int_{\gamma-i\infty}^{\gamma+i\infty} e^{zt} \frac{\cosh(x\sqrt{-z})}{\cosh(a\sqrt{-z})} dz$$

Hence show that

$$\theta = \frac{4\theta_0}{\pi} \sum_{r=0}^{\infty} \frac{(-1)^{r+1}}{2r-1} e^{-(r+\frac{1}{2})^2 \pi^2 t/a^2} \cos \frac{(r-\frac{1}{2})\pi x}{a}$$

19. The free symmetrical vibrations of a very large membrane are governed by the equation

$$\frac{\partial^2 z}{\partial r^2} - \frac{1}{r} \frac{\partial z}{\partial r} = \frac{1}{c^2} \frac{\partial^2 z}{\partial t^2} \quad r > 0, t \geq 0$$

with $z = f(r)$, $\partial z / \partial t = g(r)$ when $t = 0$. Show that, for $t > 0$,

$$z(r, t) = \int_0^{\infty} \xi f(\xi) \cos(\xi ct) J_0(\xi r) d\xi + \frac{1}{c} \int_0^{\infty} \bar{g}(\xi) \sin(\xi ct) J_0(\xi r) d\xi$$

where $\bar{f}(\xi)$, $\bar{g}(\xi)$ are the zero-order Hankel transforms of $f(r)$, $g(r)$, respectively.

20. The potential $V(\rho, z)$ of a flat circular electrified disk of conducting material with center at the origin, unit radius, and axis along the z axis satisfies the differential equation

$$\frac{\partial^2 V}{\partial \rho^2} + \frac{1}{\rho} \frac{\partial V}{\partial \rho} + \frac{\partial^2 V}{\partial z^2} = 0$$

($\rho > 0, z > 0$) and the boundary conditions

$$(i) \quad V \rightarrow 0 \quad \text{as } z, \rho \rightarrow \infty$$

$$(ii) \quad V = V_0, \quad z = 0 \quad 0 < \rho < 1$$

$$(iii) \quad \frac{\partial V}{\partial z} = 0, \quad z = 0 \quad \rho > 1$$

Prove that

$$V(\rho, z) = \int_0^{\infty} f(\xi) e^{-\xi z} J_0(\xi \rho) d\xi$$

where the function f satisfies the relations

$$\int_0^{\infty} f(\xi) J_0(\xi \rho) d\xi = V_0 \quad 0 < \rho < 1$$

$$\int_0^{\infty} \xi f(\xi) J_0(\xi \rho) d\xi = 0 \quad \rho > 1$$

Verify that $f(\xi) = (2V_0 \sin \xi)/(\pi \xi)$ is a solution of these equations, and hence evaluate $V(\rho, z)$.

Chapter 4

LAPLACE'S EQUATION

In the last chapter we saw how second-order linear partial differential equations could be grouped into three main types, elliptic, hyperbolic, and parabolic. The next three chapters will be devoted to the consideration in a little more detail of examples of equations of the three types drawn from mathematical physics. We shall begin by considering *Laplace's equation*, $\nabla^2\psi = 0$, which is the elliptic equation occurring most frequently in physical problems. Because the function ψ , which occurs in Laplace's equation, is frequently a potential function, this equation is often referred to as the *potential equation*.

1. The Occurrence of Laplace's Equation in Physics

We saw in Sec. 3 of Chap. 3 that problems in electrostatics could be reduced to finding appropriate solutions of Laplace's equation $\nabla^2\psi = 0$. This is typical of a procedure which is adopted frequently in mathematical physics. We shall not give such a derivation for the most frequently occurring physical situations, but since in discussing Laplace's equation it is useful to be able to illustrate the theory with reference to physical problems, we shall summarize here the main relations in some of the branches of physics in which the field equations can be reduced to Laplace's equation.

(a) *Gravitation.* (i) Both inside and outside the attracting matter the force of attraction \mathbf{F} can be expressed in terms of a *gravitational potential* ψ by the equation

$$\mathbf{F} = \text{grad } \psi$$

(ii) In empty space ψ satisfies Laplace's equation $\nabla^2\psi = 0$.

(iii) At any point at which the density of gravitating matter is ρ the potential ψ satisfies *Poisson's equation* $\nabla^2\psi = -4\pi\rho$.

(iv) When there is matter distributed over a surface, the potential function ψ assumes different forms ψ_1 , ψ_2 on opposite sides of the surface, and on the surface these two functions satisfy the conditions

$$\psi_1 = \psi_2, \quad \frac{\partial\psi_2}{\partial n} - \frac{\partial\psi_1}{\partial n} = -4\pi\sigma$$

where σ is the surface density of the matter and n is the normal to the surface pointing from the region 1 into the region 2.

(v) There can be no singularities in ψ except at isolated masses.

(b) *Irrotational Motion of a Perfect Fluid.* (i) The velocity \mathbf{q} of a perfect fluid in irrotational motion can be expressed in terms of a *velocity potential* ψ by the equation

$$\mathbf{q} = -\text{grad } \psi$$

(ii) At all points of the fluid where there are no sources or sinks the function ψ satisfies Laplace's equation $\nabla^2\psi = 0$.

(iii) When the fluid is in contact with a rigid surface which is moving so that a typical point P of it has velocity \mathbf{U} , then $(\mathbf{q} - \mathbf{U}) \cdot \mathbf{n} = 0$, where \mathbf{n} is the direction of the normal at P . The condition satisfied by ψ is therefore that

$$\frac{\partial\psi}{\partial n} = -(\mathbf{U} \cdot \mathbf{n})$$

at all points of the surface.

(iv) If the fluid is at rest at infinity, $\psi \rightarrow 0$, but if there is a uniform velocity V in the z direction, this condition is replaced by the condition $\psi \sim -Vz$ as $z \rightarrow \infty$.

(v) The function ψ has no singularities except at sources or sinks.

(c) *Electrostatics.* (i) The electric vector \mathbf{E} can be expressed in terms of an *electrostatic potential* ψ by the equation $\mathbf{E} = -\text{grad } \psi$.

(ii) In empty space ψ satisfies Laplace's equation $\nabla^2\psi = 0$.

(iii) In the presence of charges ψ satisfies Poisson's equation $\nabla^2\psi = -4\pi\rho$, where ρ is the density of electric charge.

(iv) The function ψ is constant on any conductor.

(v) If n is the outward-drawn normal to a conductor, then at each point of the conductor

$$\frac{\partial\psi}{\partial n} = -4\pi\sigma$$

where σ is the surface density of the electric charge on the conductor. The total charge on the conductor is therefore

$$- \frac{1}{4\pi} \int \frac{\partial\psi}{\partial n} dS$$

where the integral is taken over the surface of the conductor.

(vi) With a finite system of charges the function $\psi \rightarrow 0$ at infinity, but if there is a uniform field E_0 in the z direction at infinity, then $\psi \sim -E_0z$ as $z \rightarrow \infty$.

(vii) There can be no singularities in ψ except at isolated charges, dipoles, etc. Near a charge q , $\psi = q/r$ is finite, r being measured from

the charge. Similarly in the neighborhood of a dipole of moment \mathbf{m} in a vacuum $\psi = (\mathbf{m} \cdot \mathbf{r})/r^3$ is finite.

(d) *Dielectrics.* In the presence of dielectrics the electrostatic potential ψ defined as in $\epsilon(i)$ above satisfies the conditions:

(i) In the presence of charges $\text{div}(\kappa \text{grad } \psi) = -4\pi\rho$, where κ is the dielectric constant.

(ii) If we have two media in contact, we have two forms ψ_1, ψ_2 for the potential on opposite sides of the surface, but on the surface we have

$$\psi_1 = \psi_2, \quad \kappa_1 \frac{\partial \psi_1}{\partial n} = \kappa_2 \frac{\partial \psi_2}{\partial n}$$

where n is the common normal.

(iii) At the surface of a conductor $\epsilon(v)$ is replaced by the equation

$$\kappa \frac{\partial \psi}{\partial n} = -4\pi\sigma$$

(e) *Magnetostatics.* (i) The magnetic vector \mathbf{H} can be expressed in terms of a *magnetostatic potential* ψ by the equation $\mathbf{H} = -\text{grad } \psi$.

(ii) If μ is the magnetic permeability, ψ satisfies the equation

$$\text{div}(\mu \text{grad } \psi) = 0$$

which reduces to Laplace's equation when μ is a constant.

(iii) At a sudden change of medium

$$\psi_1 = \psi_2, \quad \mu_1 \frac{\partial \psi_1}{\partial n} = \mu_2 \frac{\partial \psi_2}{\partial n}$$

(iv) In the presence of a constant field H_0 in the z direction at infinity we have $\psi \sim -H_0 z$ as $z \rightarrow \infty$.

(v) In the neighborhood of a magnet of moment \mathbf{m} in a vacuum $\psi = (\mathbf{m} \cdot \mathbf{r})/r^3$ is finite, r being measured from the center of the magnet.

(f) *Steady Currents.* (i) The conduction current vector \mathbf{j} may be derived from a potential function ψ through the formula

$$\mathbf{j} = -\sigma \text{grad } \psi$$

where σ is the conductivity.

(ii) The function ψ satisfies the equation

$$\text{div}(\sigma \text{grad } \psi) = 0$$

which reduces in the case $\sigma = \text{constant}$ to Laplace's equation.

(iii) At the surface of an electrode at which a battery is providing charge at a definite potential the function ψ is constant. If the total current leaving the electrode is i , then

$$\int \sigma \frac{\partial \psi}{\partial n} dS = -i$$

(iv) At the boundary between a conductor and an insulator or vacuum there is no normal flow of current, so that

$$\frac{\partial \psi}{\partial n} = 0$$

(g) *Surface Waves on a Fluid.* The velocity potential ψ of two-dimensional wave motions of small amplitude in a perfect fluid under gravity satisfies the conditions:

- (i) $\nabla^2 \psi = 0$;
- (ii) $\partial^2 \psi / \partial t^2 = g(\partial \psi / \partial y) = 0$ on the mean free surface, y being measured to increase with depth;
- (iii) $\partial \psi / \partial n = 0$ on a fixed boundary.

(h) *Steady Flow of Heat.* In the case of steady flow in the theory of the conduction of heat the temperature ψ does not vary with the time. It satisfies the conditions:

- (i) $\text{div}(\kappa \text{grad } \psi) = 0$, where κ is the thermal conductivity, or $\nabla^2 \psi = 0$ if κ is a constant throughout the medium;
- (ii) $\partial \psi / \partial n = 0$ if there is no flux of heat across the boundary;
- (iii) $\partial \psi / \partial n = h(\psi - \psi_0) = 0$, where h is a constant, when there is radiation from the surface into a medium at constant temperature ψ_0 .

PROBLEMS

1. Prove Gauss' theorem that the outward flux of the force of attraction over any closed surface in a gravitational field of force is equal to -4π times the mass enclosed by the surface.

Deduce that (a) the potential cannot have a maximum or a minimum value at any point of space unoccupied by matter; (b) if the potential is constant over a closed surface containing no matter, it must be constant throughout the interior.

2. The function ψ_i is defined inside a closed surface S ; the function ψ_o is defined outside S , and $\nabla^2 \psi_o = 0$. What other conditions must be satisfied by ψ_i and ψ_o in order that they should be the internal and external gravitational potentials of a distribution of matter inside S of density $-\nabla^2 \psi_i / 4\pi$?

Verify that the conditions are satisfied by the potential of a uniform sphere

$$\psi_o = \frac{4}{3}\pi\rho \frac{a^3}{r}, \quad \psi_i = \frac{2}{3}\pi\rho (3a^2 - r^2)$$

3. Find the distribution which gives rise to the potential

$$\psi = \begin{cases} a^2 - 3x^2 & r < a \\ \frac{a^2(1^2 - z^2 - 2x^2)}{r^3} & r > a \end{cases}$$

where $r^2 = x^2 + y^2 + z^2$.

4. Find a distribution which gives rise to the potential

$$\psi = \begin{cases} \frac{1}{3}\pi \log R & R < 1 \\ \frac{\pi}{9} \log R - \frac{\pi}{9} (5 - 9R^2 + 4R^3) & R > 1 \end{cases}$$

where $R^2 = x^2 + y^2$.

5. Find the distribution of electric charge which gives rise to the potential

$$\psi = \begin{cases} 0 & x < 0 \\ k((x-a)^2 - y^2 - z^2)^{-1/2} & ((x-a)^2 - y^2 - z^2)^{-1/2} > 0 \end{cases} \quad x > 0$$

and calculate the total charge present on the plane $x = 0$.

6. Show that the velocity potential

$$\psi = \frac{1}{2} Va^3 r^{-2} \cos \theta$$

satisfies all the conditions associated with the rectilinear motion of a sphere of radius a moving through a perfect incompressible fluid which is moving irrotationally and is at rest at infinity.

2. Elementary Solutions of Laplace's Equation

If we take the function ψ to be given by the equation

$$\psi = \frac{q}{|\mathbf{r} - \mathbf{r}'|} = \frac{q}{\sqrt{(x-x')^2 + (y-y')^2 + (z-z')^2}} \quad (1)$$

where q is a constant and (x', y', z') are the coordinates of a *fixed* point, then since

$$\frac{\partial \psi}{\partial x} = -\frac{q(x-x')}{|\mathbf{r} - \mathbf{r}'|^3}, \text{ etc.}$$

$$\frac{\partial^2 \psi}{\partial x^2} = -\frac{q}{|\mathbf{r} - \mathbf{r}'|^3} + \frac{3q(x-x')^2}{|\mathbf{r} - \mathbf{r}'|^5}, \text{ etc.}$$

it follows that

$$\nabla^2 \psi = 0$$

showing that the function (1) is a solution of Laplace's equation except possibly at the point (x', y', z') , where it is not defined.

From what we have said in (c) of Sec. 1 it follows that the function ψ given by equation (1) is a possible form for the electrostatic potential corresponding to a space which, apart from the isolated point (x', y', z') , is empty of electric charge. To find the charge at this singular point we make use of Gauss' theorem (Problem 1 of Sec. 1). If S is any sphere with center (x', y', z') , then it is easily shown that

$$\int_S \frac{\partial \psi}{\partial n} dS = -4\pi q$$

from which it follows, by Gauss' theorem, that equation (1) gives the solution of Laplace's equation corresponding to an electric charge $+q$.

By a simple superposition procedure it follows immediately that

$$\psi = \sum_{i=1}^n \frac{q_i}{|\mathbf{r} - \mathbf{r}_i|} \quad (2)$$

is the solution of Laplace's equation corresponding to n charges q_i situated at points with position vectors \mathbf{r}_i ($i = 1, 2, \dots, n$).

In electrical problems we encounter the situation where two charges $+q$ and $-q$ are situated very close together, say at points \mathbf{r}' and $\mathbf{r}' + \delta\mathbf{r}'$, where $\delta\mathbf{r}' = (l, m, n)a$. The solution of Laplace's equation corresponding to this distribution of charge is

$$\psi = \frac{q}{|\mathbf{r} - \mathbf{r}'|} - \frac{q}{|\mathbf{r} - \mathbf{r}' - \delta\mathbf{r}'|}$$

Now

$$\frac{1}{|\mathbf{r} - \mathbf{r}' - \delta\mathbf{r}'|} = \frac{1}{|\mathbf{r} - \mathbf{r}'|} \left[1 + \frac{l(x - x') + m(y - y') + n(z - z')}{|\mathbf{r} - \mathbf{r}'|^3} a + O(a^2) \right]$$

so that if $a \rightarrow 0$, $q \rightarrow \infty$ in such a way that $qa \rightarrow \mu$, i.e., an electric dipole is formed, it follows that the corresponding solution of Laplace's equation is

$$\psi = \mu \frac{l(x - x') + m(y - y') + n(z - z')}{|\mathbf{r} - \mathbf{r}'|^3} \quad (3)$$

a result which may be written in other ways: If we introduce a vector $\mathbf{m} = \mu(l, m, n)$, then

$$\psi = \frac{\mathbf{m} \cdot (\mathbf{r} - \mathbf{r}')}{|\mathbf{r} - \mathbf{r}'|^3} \quad (4)$$

Also since

$$\frac{\partial}{\partial x'} \frac{1}{|\mathbf{r} - \mathbf{r}'|} = \frac{x - x'}{|\mathbf{r} - \mathbf{r}'|^3}, \text{ etc.}$$

it follows that (3) may be written in the form

$$\psi = (\mathbf{m} \cdot \text{grad}') \frac{1}{|\mathbf{r} - \mathbf{r}'|} = \mu \left(l \frac{\partial}{\partial x'} + m \frac{\partial}{\partial y'} + n \frac{\partial}{\partial z'} \right) \frac{1}{|\mathbf{r} - \mathbf{r}'|} \quad (5)$$

In reality we usually have to deal with continuous distributions of charge rather than with point charges or dipoles. By analogy with equation (2) we should therefore expect that when a continuous distribution of charge fills a region V of space, the corresponding form of the function ψ of (e) of Sec. I is given by the Stieltjes integral¹

$$\psi = \int_V \frac{dq}{|\mathbf{r} - \mathbf{r}'|} \quad (6)$$

¹ For a discussion of the analytical properties of such Stieltjes potentials the reader is referred to G. C. Evans, *Fundamental Points of Potential Theory*, *Rice Inst. Pamph.*, 7 (4), 252-293 (October, 1920).

where q is the Stieltjes measure of the charge at the point \mathbf{r}' , or if ρ denotes the charge density, by

$$\psi(\mathbf{r}) = \int_V \frac{\rho(\mathbf{r}') d\tau'}{|\mathbf{r} - \mathbf{r}'|} \quad (7)$$

By a similar argument it can be shown that the solution corresponding to a surface S carrying an electric charge of density σ is

$$\psi(\mathbf{r}) = \int_S \frac{\sigma(\mathbf{r}') dS'}{|\mathbf{r} - \mathbf{r}'|} \quad (8)$$

Example 1. If $\rho \geq 0$ and $\psi(r)$ is given by equation (7), where the volume V is bounded, prove that

$$\lim_{r \rightarrow \infty} r\psi(r) = M$$

where

$$M = \int_V \rho(\mathbf{r}') d\tau'$$

Let r_1, r_2 be the maximum and minimum values of the distance $|\mathbf{r} - \mathbf{r}'|$ from the point \mathbf{r} to the integration points \mathbf{r}' of the bounded volume V . Then by a theorem of elementary calculus

$$\frac{M}{r_1} < \int_V \frac{\rho(\mathbf{r}') d\tau'}{|\mathbf{r} - \mathbf{r}'|} < \frac{M}{r_2}$$

an equality which may be written in the form

$$\left(\frac{r}{r_1}\right) M < r\psi(r) < \left(\frac{r}{r_2}\right) M$$

Now as $r \rightarrow \infty$, r/r_1 and r/r_2 both tend to unity, so that

$$\lim_{r \rightarrow \infty} r\psi(r) = M$$

PROBLEMS

1. Prove that $r \cos \theta$ and $r^{-2} \cos \theta$ satisfy Laplace's equation, when r, θ, ϕ are spherical polar coordinates.

An electric dipole of moment μ is placed at the center of a uniform hollow conducting sphere of radius a which is insulated and has a total charge e . Verify that V_i , the potential inside the sphere, and V_0 , the potential outside the sphere, are given by

$$V_i = \frac{e}{a} + \frac{\mu \cos \theta}{r^2} - \frac{\mu r}{a^3} \cos \theta, \quad V_0 = \frac{e}{r}$$

where r is measured from the center of the sphere and θ is the angle between the radius vector and the positive direction of the dipole.

2. A surface S carries an electrical charge of density σ . In the negative direction of the normal from each point P of S there is located a point P_1 at a constant distance h , thus forming a parallel surface S_1 . Assuming that corresponding points P and P_1 have the same normal and that corresponding elements of area carry numerically equal charges of opposite sign, show that the potential function of the system is

$$\psi = \int_S \left(\frac{1}{|\mathbf{r} - \mathbf{r}'|} - \frac{1}{|\mathbf{r} - \mathbf{r}' - h\mathbf{n}|} \right) \sigma(\mathbf{r}') dS'$$

By letting $h = 0$, $\rho = \sigma \delta(r - r')$ in such a way that $\sigma h = \rho$ everywhere uniformly on S , obtain the expression

$$\psi = \int_S \frac{\mu \{ \mathbf{n} \cdot (\mathbf{r} - \mathbf{r}') \}}{|\mathbf{r} - \mathbf{r}'|^3} dS'$$

for the potential of an electrical double layer.

3. A closed equipotential surface S contains matter which can be represented by a volume density σ . By substituting $\psi' = |\mathbf{r} - \mathbf{r}'|^{-1}$ in Green's theorem¹

$$\int_S \left(\psi' \frac{\partial \psi}{\partial n} - \psi \frac{\partial \psi'}{\partial n} \right) dS = \int_V (\psi' \nabla^2 \psi - \psi \nabla^2 \psi') d\tau$$

prove that

$$\int_S \left(\frac{\partial \psi}{\partial n} \right) \frac{dS'}{|\mathbf{r} - \mathbf{r}'|} - 4\pi \int_V \frac{\rho(r') d\tau'}{|\mathbf{r} - \mathbf{r}'|} = 0$$

Deduce that the matter contained within any closed equipotential surface S can be thought of as spread over the surface S with surface density

$$-\frac{1}{4\pi} \frac{\partial \psi}{\partial n}$$

at any point.²

4. By applying Green's theorem in the above form to the region between an equipotential surface S and the infinite sphere with $\psi' = |\mathbf{r} - \mathbf{r}'|^{-1}$ and ψ the potential of the whole distribution of matter, prove that the potential inside S due to the joint effects of Green's equivalent layer and the original matter outside S is the constant potential of S .
5. Show that

$$\int_V \frac{d\tau'}{|\mathbf{r} - \mathbf{r}'|} \leq 2\pi \left(\frac{3V}{4\pi} \right)^{\frac{1}{3}}$$

irrespective of whether the point with position vector \mathbf{r} is inside or outside the volume V or on the surface bounding it.

6. Prove that the potential

$$\psi(\mathbf{r}) = \int_V \frac{\rho(\mathbf{r}') d\tau'}{|\mathbf{r} - \mathbf{r}'|}$$

and its first derivatives are continuous when the point P with position vector \mathbf{r} lies inside or on the boundary of V .

Show further that $\nabla^2 \psi = -4\pi\rho$ if $P \in V$ and that $\nabla^2 \psi = 0$ if $P \notin V$.

3. Families of Equipotential Surfaces

If the function $\psi(x, y, z)$ is a solution of Laplace's equation, the one-parameter system of surfaces

$$\psi(x, y, z) = c$$

is called a family of *equipotential* surfaces. It is not true, however, that any one-parameter family of surfaces

$$f(x, y, z) = c \tag{1}$$

¹ H. Lass, "Vector and Tensor Analysis" (McGraw-Hill, New York, 1950), p. 118.

² This distribution is known as *Green's equivalent layer*.

a family of equipotential surfaces. This will be so only if a certain condition is satisfied; we shall now derive the necessary condition.

The surfaces (1) will be equipotential if the potential function ψ is constant whenever $f(x, y, z)$ is constant. There must therefore be a functional relation of the type

$$\psi = F\{f(x, y, z)\} \quad (2)$$

between the functions ψ and f . Differentiating equation (2) partially with respect to x , we obtain the result

$$\frac{\partial \psi}{\partial x} = \frac{dF}{df} \frac{\partial f}{\partial x} \quad (3)$$

and hence the relation

$$\frac{\partial^2 \psi}{\partial x^2} = \frac{d^2 F}{df^2} \left(\frac{\partial f}{\partial x}\right)^2 + \frac{dF}{df} \frac{\partial^2 f}{\partial x^2} \quad (4)$$

from which it follows that

$$\nabla^2 \psi = F''(f)(\text{grad } f)^2 + F'(f)\nabla^2 f \quad (5)$$

Now, in free space, $\nabla^2 \psi = 0$, so that the required necessary condition is that

$$\frac{\nabla^2 f}{(\text{grad } f)^2} = -\frac{F''(f)}{F'(f)} \quad (6)$$

Hence the condition that the surfaces (1) form a family of equipotential surfaces in free space is that the quantity

$$\frac{\nabla^2 f}{|\text{grad } f|^2}$$

is a function of f alone.

If we denote this function by $\chi(f)$, then equation (6) may be written

$$\frac{d^2 F}{df^2} + \chi(f) \frac{dF}{df} = 0$$

from which it follows that

$$\frac{dF}{df} = A e^{-\int \chi(f) df}$$

where A is a constant, and hence that

$$\psi = A \int e^{-\int \chi(f) df} df + B \quad (7)$$

where A and B are constants.

Example 2. Show that the surfaces

$$x^2 - y^2 + z^2 = cx^3$$

in form a family of equipotential surfaces, and find the general form of the corresponding potential function.

In the notation of equation (1)

$$f = x^3 + x^{-3}(y^2 + z^2)$$

so that

$$\text{grad } f = \frac{2}{3}x^{-4}(2x^2 + y^2 + z^2, 3xy, 3xz)$$

Hence

$$\nabla^2 f = \frac{10}{9}x^{-7}(4x^2 + y^2 + z^2)$$

and

$$|\text{grad } f|^2 = \frac{4}{9}x^{-10}(4x^2 + y^2 + z^2)(x^2 + y^2 + z^2)$$

so that $\nabla^2 f / |\text{grad } f|^2 = z(f)$, where $z(f) = 5/(2f)$. The given set of surfaces therefore forms a family of equipotential surfaces.

Substituting $5/(2f)$ for $z(f)$ in equation (7), we find that

$$\psi = Af^{-\frac{1}{2}} + B$$

from which it follows that the required potential function is

$$\psi = Ax(x^2 + y^2 + z^2)^{-\frac{1}{2}} + B$$

where A and B are constants.

PROBLEMS

1. Show that the surfaces

$$(x^2 + y^2)^2 - 2a^2(x^2 - y^2) + a^4 = c$$

can form a family of equipotential surfaces, and find the general form of the corresponding potential function.

2. Show that the family of right circular cones

$$x^2 + y^2 = cz^2$$

where c is a parameter, forms a set of equipotential surfaces, and show that the corresponding potential function is of the form $A \log \tan \frac{1}{2}\theta + B$, where A and B are constants and θ is the usual polar angle.

3. Show that if the curves $f(x, y) = c$ form a system of equipotential lines in free space for a two-dimensional system, the surfaces formed by their revolution about the x axis do not constitute a system of equipotential surfaces in free space unless

$$\frac{1}{y} \left(\frac{\partial f}{\partial y} \right)^2 \div \left\{ \left(\frac{\partial f}{\partial x} \right)^2 - \left(\frac{\partial f}{\partial y} \right)^2 \right\}$$

is a constant or a function of c only.

Show that the cylinders $x^2 + y^2 + 2cx$ form a possible set of equipotential surfaces in free space but that the spheres $x^2 + y^2 + z^2 = 2cx$ do not.

4. Show that the surfaces

$$x^2 - y^2 + 2cx + a^2 = 0$$

where a is fixed and c is a parameter specifying a particular surface of the family, form a set of equipotential surfaces.

The cylinder of parameter c_1 completely surrounds that of parameter c_2 , and $c_2 > a > 0$. The first is grounded, and the second carries a charge E per unit length. Prove that its potential is

$$-E \log \frac{(c_1 + a)(c_2 - a)}{(c_1 - a)(c_2 + a)}$$

4. Boundary Value Problems

In Sec. 1 of this chapter we have seen that in the discussion of certain physical problems the function ψ whose analytical form we are seeking must, in addition to satisfying Laplace's equation within a certain region of space V , also satisfy certain conditions on the boundary S of this region. Any problem in which we are required to find such a function ψ is called a *boundary value problem for Laplace's equation*.

There are two main types of boundary value problem for Laplace's equation, associated with the names of Dirichlet and Neumann. By the *interior Dirichlet problem* we mean the following problem:

If f is a continuous function prescribed on the boundary S of some finite region V , determine a function $\psi(x, y, z)$ such that $\nabla^2\psi = 0$ within V and $\psi = f$ on S .

In a similar way the *exterior Dirichlet problem* is the name applied to the problem:

If f is a continuous function prescribed on the boundary S of a finite simply connected region V , determine a function $\psi(x, y, z)$ which satisfies $\nabla^2\psi = 0$ outside V and is such that $\psi = f$ on S .

For instance, the problem of finding the distribution of temperature within a body in the steady state when each point of its surface is kept at a prescribed steady temperature is an interior Dirichlet problem, while that of determining the distribution of potential outside a body whose surface potential is prescribed is an exterior Dirichlet problem.

The existence of the solution of a Dirichlet problem under very general conditions can be established. Assuming the existence of the solution of an interior Dirichlet problem, it is a simple matter to prove its uniqueness. Suppose that ψ_1 and ψ_2 are both solutions of the interior Dirichlet problem in question. Then the function

$$\psi = \psi_1 - \psi_2$$

must be such that $\nabla^2\psi = 0$ within V and $\psi = 0$ on S . Now by Prob. 1 of Sec. 1 of this chapter we know that the values of ψ within V cannot exceed its maximum on S or be less than its minimum on S , so that we must have $\psi = 0$ within V ; i.e., $\psi_1 = \psi_2$ within V . It should also be observed that the solution of a Dirichlet problem depends continuously on the boundary function (cf. Example 1 below).

On the other hand, the solution of the exterior Dirichlet problem is not unique unless some restriction is placed on the behavior of $\psi(x, y, z)$ as $r \rightarrow \infty$. In the three-dimensional case it can be proved¹ that the solution of the exterior Dirichlet problem is unique provided that

$$|\psi(x, y, z)| < \frac{C}{r}$$

¹ See Sec. 8.

where C is a constant. In the two-dimensional case we require the function ψ to be bounded at infinity.

In cases where the region V is bounded the solution of the exterior Dirichlet problem can be deduced from that of a corresponding interior Dirichlet problem. Within the region V we choose a spherical surface C with center O and radius a . We next invert the space outside the region V with respect to the sphere C ; i.e., we map a point P outside V into a point Π inside the sphere C such that

$$OP \cdot O\Pi = a^2$$

In this way the region exterior to the surface S is mapped into a region

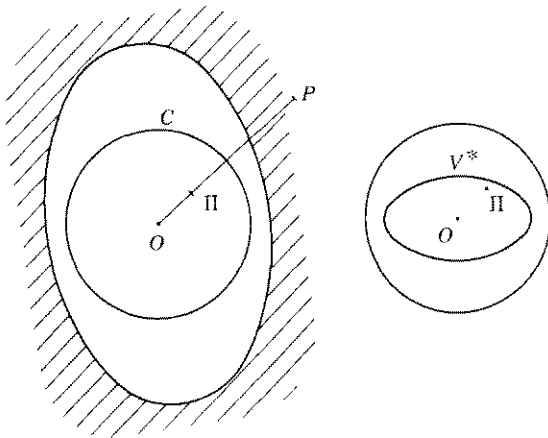

Figure 21

V^* lying entirely within the sphere C (cf. Fig. 21). It can be easily shown that if

$$f^*(\Pi) = \frac{a}{O\Pi} f(P)$$

and if $\psi^*(\Pi)$ is the solution of the interior Dirichlet problem

$$\nabla^2 \psi^* = 0 \text{ within } V^*, \quad \psi^* = f^*(\Pi) \text{ for } \Pi \in S^*$$

then

$$\psi(P) = \frac{a}{OP} \psi^*(\Pi)$$

is the solution of the exterior Dirichlet problem

$$\nabla^2 \psi = 0 \text{ outside } V, \quad \psi = f(P) \text{ for } P \in S$$

Lebesgue has shown by a specific example that in three-dimensional regions whose boundaries contain certain types of singularities the Dirichlet problem may not possess a solution assuming prescribed values at all points of the boundary. Consider, for example, the

potential due to a charge kz on the segment $0 \leq z \leq 1$, $x = y = 0$. It is readily proved by the methods of Sec. 1 that the requisite potential is

$$v(x, y, z) = \int_0^1 \frac{z' dz'}{\sqrt{x^2 + y^2 + (z - z')^2}}$$

which can be expressed in the form

$$v_0(x, y, z) = z \log(x^2 + y^2)$$

where $v_0(x, y, z)$ is continuous at the origin and takes the value 1 there. The second term takes the value c at each point of the surface whose equation is

$$(x^2 + y^2) = e^{-c/2z}$$

which passes through the origin whatever value c has. In other words, any equipotential surface on which $v = 1 + c$ passes through the origin, so that the potential at the origin is undefined.

The second type of boundary value problem is associated with the name of Neumann. By the *interior Neumann problem* we mean the following problem:

If f is a continuous function which is defined uniquely at each point of the boundary S of a finite region V , determine a function $\psi(x, y, z)$ such that $\nabla^2 \psi = 0$ within V and its normal derivative $\partial\psi/\partial n$ coincides with f at every point of S .

In a similar way the *exterior Neumann problem* is the name given to the problem:

If f is a continuous function prescribed at each point of the (smooth) boundary S of a bounded simply connected region V , find a function $\psi(x, y, z)$ satisfying $\nabla^2 \psi = 0$ outside V and $\partial\psi/\partial n = f$ on S .

We can readily establish a necessary condition for the existence of the solution of the interior Neumann problem. Putting $\mathbf{a} = \text{grad } \psi$ in Gauss' theorem

$$\int_S a_n dS = \int_V \text{div } \mathbf{a} d\tau$$

we find that

$$\int_V \nabla^2 \psi d\tau = \int_S \frac{\partial\psi}{\partial n} dS$$

Now on the boundary

$$\frac{\partial\psi}{\partial n} = f(P) \quad P \in S$$

so that

$$\int_V \nabla^2 \psi d\tau = \int_S f(P) dS$$

Hence if $\nabla^2 \psi = 0$, we have

$$\int_S f(P) dS = 0 \quad (1)$$

showing that a necessary condition for the existence of a solution of the problem is that the integral of f over the boundary S should vanish.

It is possible to reduce the exterior Neumann problem to the interior Neumann problem just as in the case of the Dirichlet problems (see Prob. 3 below).

In the two-dimensional case it is possible to reduce the Neumann problem to the Dirichlet problem. Suppose that a solution ψ of the Neumann problem

$$\begin{aligned} \text{(i)} \quad & \nabla^2 \psi = 0 \quad \text{within } S \\ \text{(ii)} \quad & \frac{\partial \psi}{\partial n} = f(P) \quad \text{for } P \in C \end{aligned}$$

exists and is such that ψ and its partial derivatives with respect to x, y can be extended continuously to the boundary C of the plane region S . We can now construct a function ϕ which, within S and on C , satisfies the Cauchy-Riemann equations¹

$$\frac{\partial \psi}{\partial x} = \frac{\partial \phi}{\partial y}, \quad \frac{\partial \psi}{\partial y} = -\frac{\partial \phi}{\partial x}$$

so that $\psi + i\phi$ is an analytic function of the complex variable $x + iy$. The function ϕ is therefore defined uniquely apart from a constant term. Now it is well known that

$$\frac{\partial \phi}{\partial s} = \frac{\partial \psi}{\partial n}$$

so that if P, Q are two points on the boundary curve C , then

$$\phi(Q) - \phi(P) = \int_P^Q \frac{\partial \phi}{\partial s} ds = \int_P^Q f(s) ds \quad (2)$$

Since, by an argument analogous to that leading to equation (1),

$$\int_C f(s) ds = 0$$

it follows that equation (2) defines ϕ on C as a continuous and single-valued function, and it is readily shown that if ψ is harmonic, then so also is ϕ . Hence knowing the value of ϕ on C , we can determine ϕ within S . Using the Cauchy-Riemann equations then, apart from a constant term, we can determine the function ψ within S .

Recently Churchill² has analyzed a boundary value problem of a type different from those of Dirichlet and Neumann. By the *interior Dirichlet problem* we shall mean the problem:

¹ See, for example, *J. Math. and Phys.*, **33**, 165 (1954).

If f is a continuous function prescribed on the boundary S of a finite region V , determine a function $\psi(x, y, z)$ such that $\nabla^2\psi = 0$ within V and

$$\frac{\partial\psi}{\partial n} + (k \pm 1)\psi = f$$

every point of S .

An *exterior Churchill problem* can be defined in a similar manner.

PROBLEMS

If ψ_1, ψ_2 are solutions of the Dirichlet problem for some region V corresponding to prescribed boundary values f_1, f_2 , respectively, and if $|f_1 - f_2| < \epsilon$ at all points of S , prove that $|\psi_1 - \psi_2| < \epsilon$ at all points of V .

Deduce that if a given sequence of functions which is harmonic within V and is continuous in V and on S converges uniformly on S , then this sequence converges uniformly within V .

Prove that the solutions of a certain Neumann problem can differ from one another by a constant only.

Prove, with the notation of this section, that if

$$f^*(\Pi) - f(P) \frac{\partial n}{\partial n^*}$$

and if $\psi^*(\Pi)$ is the solution of the interior Neumann problem

$$\nabla^2\psi^* = 0 \text{ within } V^*, \quad \frac{\partial\psi^*}{\partial n^*} = f^*(\Pi) \text{ for } \Pi \in S^*$$

then $\psi(P) = \psi^*(\Pi)$ is the solution of the exterior Neumann problem

$$\nabla^2\psi = 0 \text{ outside } V, \quad \frac{\partial\psi}{\partial n} = f(P) \text{ for } P \in S$$

Prove that the solution $\psi(r, \theta, \phi)$ of the exterior Dirichlet problem for the unit sphere

$$\nabla^2\psi = 0, \quad r > 1, \quad \psi = f(\theta, \phi) \text{ on } r = 1$$

is given in terms of the solution $v(r, \theta, \phi)$ of the interior Dirichlet problem

$$\nabla^2v = 0, \quad r < 1, \quad v = f(\theta, \phi) \text{ on } r = 1$$

by the formula

$$\psi(r, \theta, \phi) = \frac{1}{r} v\left(\frac{1}{r}, \theta, \phi\right)$$

Prove that the solution $\psi(r, \theta, \phi)$ of the interior Neumann problem for the unit sphere

$$\nabla^2\psi = 0, \quad r < 1, \quad \frac{\partial\psi}{\partial r} = f(\theta, \phi) \text{ on } r = 1$$

is given in terms of the solution $v(r, \theta, \phi)$ of the last question by the formula

$$\psi(r, \theta, \phi) = \int_0^1 v(rt, \theta, \phi) \frac{dt}{t} + C$$

where C is a constant.

6. Prove that the solution $\psi(r, \theta, \phi)$ of the interior Churchill problem for the unit sphere

$$\begin{aligned} \nabla^2 \psi &= 0 & r &< 1 \\ \frac{\partial \psi}{\partial r} &= (k+1)\psi = f(\theta, \phi) & \text{on } r &= 1, k > -1 \end{aligned}$$

is given in terms of the function $v(r, \theta, \phi)$ defined in Prob. 4 by the formula

$$\psi(r, \theta, \phi) = \int_0^1 v(rt, \theta, \phi) t^k dt$$

5. Separation of Variables

We shall now apply to Laplace's equation the method of separation of variables outlined in Sec. 9 of Chap. 3.

In spherical polar coordinates r, θ, ϕ Laplace's equation takes the form

$$\frac{\partial^2 \psi}{\partial r^2} + \frac{2}{r} \frac{\partial \psi}{\partial r} + \frac{1}{r^2} \frac{\partial^2 \psi}{\partial \theta^2} + \frac{\cot \theta}{r^2} \frac{\partial \psi}{\partial \theta} + \frac{1}{r^2 \sin^2 \theta} \frac{\partial^2 \psi}{\partial \phi^2} = 0 \quad (1)$$

and it was shown in Example 5 of Sec. 9, Chap. 3 that this equation is separable with solutions of the form

$$\left\{ A_n r^n + \frac{B_n}{r^{n+1}} \right\} \Theta(\cos \theta) e^{im\phi} \quad (2)$$

where A_n, B_n, m are constants and $\Theta(\mu)$ satisfies Legendre's associated equation

$$(1 - \mu^2) \frac{d^2 \Theta}{d\mu^2} - 2\mu \frac{d\Theta}{d\mu} + \left\{ n(n+1) - \frac{m^2}{1 - \mu^2} \right\} \Theta = 0 \quad (3)$$

If we take $m = 0$, we see that equation (3) reduces to Legendre's equation

$$(1 - \mu^2) \frac{d^2 \Theta}{d\mu^2} - 2\mu \frac{d\Theta}{d\mu} + n(n+1)\Theta = 0 \quad (4)$$

In the applications we wish to consider we assume that n is a positive integer. In that case it is readily shown¹ that this equation has two independent solutions given by the formulas

$$P_n(\mu) = \frac{1}{2^n n!} \frac{d^n}{d\mu^n} (\mu^2 - 1)^n \quad (5)$$

$$Q_n(\mu) = \frac{1}{2} P_n(\mu) \log \frac{\mu + 1}{\mu - 1} - \sum_{s=0}^{n-1} \frac{2n - 4s - 1}{(2s - 1)(n - s)} P_{n-2s-1}(\mu) \quad (6)$$

where $p = \frac{1}{2}(n - 1)$ or $\frac{1}{2}n - 1$ according as n is odd or even. The general solution of equation (4) is thus

$$\Theta = C_n P_n(\mu) + D_n Q_n(\mu) \quad (7)$$

¹ For the proof of this and other results about Legendre functions see I. N. Sneddon, "The Special Functions of Mathematical Physics" (Oliver & Boyd, Edinburgh, 1956), chap. III.

where C_n and D_n are constants. In a great many physical problems, especially those connected with concentric spherical boundaries, we know on physical grounds that the function ψ remains finite along the polar axis $\theta = 0$. Now when $\theta = 0$, $\mu = 1$, and it follows from equation (6) that $Q_n(\mu)$ is infinite, so that if ψ is to remain finite on the polar axis, we must take the constant D_n to be identically zero.¹ In these cases we therefore obtain solutions of Laplace's equation (1) of the form

$$\psi = \sum_n \left(A_n r^n + \frac{B_n}{r^{n-1}} \right) P_n(\cos \theta) \quad (8)$$

In the general case in which $m \neq 0$ we find that when $0 < m < n$, equation (3) possesses solutions of the type

$$P_n^m(\mu) = (\mu^2 - 1)^{\frac{1}{2}m} \frac{d^m P_n(\mu)}{d\mu^m} \quad (9)$$

$$Q_n^m(\mu) = (\mu^2 - 1)^{\frac{1}{2}m} \frac{d^m Q_n(\mu)}{d\mu^m} \quad (10)$$

When $\mu = \pm 1$, $Q_n^m(\mu)$ is infinite, so that in any physical problem in which it is known that ψ , i.e., ψ , does not become infinite on the polar axis we take $P_n^m(\mu)$ to be the solution of equation (3). In this way we obtain solutions of Laplace's equation (1) of the form

$$\psi = \sum_n \sum_{m=0}^n (A_{nm} r^n + B_{nm} r^{-n-1}) P_n^m(\cos \theta) e^{-im\phi} \quad (11)$$

which may be written as

$$\psi = \sum_n \left(\frac{r}{a} \right)^n \left[A_n P_n(\cos \theta) + \sum_{m=1}^n (A_{n,m} \cos m\phi + B_{n,m} \sin m\phi) P_n^m(\cos \theta) \right] \quad (12)$$

We shall illustrate the above remarks by considering first a very elementary problem in the irrotational motion of a perfect fluid.

Example 3. *A rigid sphere of radius a is placed in a stream of fluid whose velocity in the undisturbed state is V . Determine the velocity of the fluid at any point of the disturbed stream.*

We may take the polar axis Oz to be in the direction of the given velocity and take polar coordinates (r, θ, ϕ) with origin at the center of the fixed sphere.

From Sec. 1(b) we see that the velocity of the fluid is given by the vector $-\text{grad } \psi$, where

- (i) $\nabla^2 \psi = 0$
- (ii) $\frac{\partial \psi}{\partial r} = 0$ on $r = a$
- (iii) $\psi \sim -Vr \cos \theta = -Vr P_1(\cos \theta)$ as $r \rightarrow \infty$

¹ It should be noted that this is not *always* true. As an example of a problem in which $D_n \neq 0$ see Prob. 1 below.

The axially symmetrical function

$$\psi = \sum_{n=0}^{\infty} \left(A_n r^n + \frac{B_n}{r^{n+1}} \right) P_n(\cos \theta)$$

satisfies (i). Condition (ii) is satisfied if we take

$$nA_n a^{n+1} - (n+1) \frac{B_n}{a^{n+2}} = 0$$

i.e., if $B_n = na^{2n+1}A_n/(n+1)$. As $r \rightarrow \infty$, this velocity potential has the asymptotic form

$$\psi \sim \sum_{n=0}^{\infty} A_n r^n P_n(\cos \theta)$$

so that to satisfy (iii) we take $A_1 = -V$ and all the other A 's zero. Hence the required velocity potential is

$$\psi = -V \left(r + \frac{a^3}{2r^2} \right) \cos \theta$$

The components of the velocity are therefore

$$q_r = -\frac{\partial \psi}{\partial r} = V \left(1 - \frac{a^3}{r^3} \right) \cos \theta$$

$$q_\theta = -\frac{1}{r} \frac{\partial \psi}{\partial \theta} = -V \left(1 + \frac{a^3}{2r^3} \right) \sin \theta$$

A similar problem from electrostatics is:

Example 4. A uniform insulated sphere of dielectric constant κ and radius a carries on its surface a charge of density $\lambda P_n(\cos \theta)$. Prove that the interior of the sphere contributes an amount

$$\frac{8\pi^2 \lambda^2 a^3 \kappa n}{(2n+1)(\kappa n + n+1)^2}$$

to the electrostatic energy.

The electrostatic potential ψ takes the value ψ_1 inside the sphere and ψ_2 outside, where by virtue of Sec. 1(d) we have:

- (i) $\nabla^2 \psi_1 = 0, \nabla^2 \psi_2 = 0$
- (ii) ψ_1 is finite at $r = 0$; $\psi_2 \rightarrow 0$ as $r \rightarrow \infty$;
- (iii) $\psi_1 = \psi_2$ and $\kappa(\partial \psi_1 / \partial r) - \partial \psi_2 / \partial r = 4\pi \lambda P_n(\cos \theta)$ on $r = a$.

Conditions (i), (ii), and the first of (iii) and the condition of axial symmetry are satisfied if we take

$$\psi_1 = A \left(\frac{r}{a} \right)^n P_n(\cos \theta), \quad \psi_2 = A \left(\frac{a}{r} \right)^{n+1} P_n(\cos \theta)$$

and the second of (iii) is satisfied if we choose A so that

$$\left[\frac{n\kappa}{a} + \frac{(n+1)}{a} \right] A = 4\pi \lambda$$

Hence the required potential function is

$$\psi_1 = \frac{4\pi a \lambda}{\kappa n + n + 1} \left(\frac{r}{a} \right)^n P_n(\cos \theta)$$

The energy due to the interior of the sphere is known from electrostatic theory to be

$$\frac{\kappa}{8\pi} \int \psi_1 \left(\frac{\partial \psi_1}{\partial n} \right) dS = \frac{\kappa}{8\pi} \frac{16\pi^2 a^2 \bar{z}^2}{(\kappa n - n - 1)^2 a} \frac{n}{a} 2\pi a^2 \int_0^\pi \sin^2 \theta P_n(\cos \theta) P_n(\cos \theta) d\theta$$

and the result follows from the known integral¹

$$\int_{-1}^1 [P_n(u)]^2 du = \frac{2}{2n+1}$$

A similar procedure holds when Laplace's equation is expressed in cylindrical coordinates (ρ, ϕ, z) . In these coordinates Laplace's equation becomes

$$\frac{\partial^2 \psi}{\partial \rho^2} + \frac{1}{\rho} \frac{\partial \psi}{\partial \rho} - \frac{1}{\rho^2} \frac{\partial^2 \psi}{\partial \phi^2} + \frac{\partial^2 \psi}{\partial z^2} = 0 \quad (13)$$

and it was shown in Example 4 of Sec. 9 of Chap. 3 that this equation possesses solutions of the form

$$R(\rho) e^{-mz} e^{in\phi} \quad (14)$$

where $R(\rho)$ is any solution of Bessel's equation

$$\frac{d^2 R}{d\rho^2} - \frac{1}{\rho} \frac{dR}{d\rho} - \left(m^2 - \frac{n^2}{\rho^2} \right) R = 0 \quad (15)$$

In the usual notation for Bessel functions the general solution of this equation is

$$R = A_{mn} J_n(m\rho) + B_{mn} Y_n(m\rho) \quad (16)$$

where A_{mn} and B_{mn} are constants. The function $Y_n(m\rho)$ becomes infinite as $\rho \rightarrow 0$, so that if we are interested in problems in which it is obvious on physical grounds that ψ remains finite along the line $\rho = 0$, we must take $B_{mn} = 0$. In this way we obtain a solution of the type

$$\psi = \sum_m \sum_n A_{mn} J_n(m\rho) e^{-mz} e^{in\phi} \quad (17)$$

For problems in which there is symmetry about the z axis we may take $n = 0$ to obtain solutions of the form

$$\psi = \sum_m A_m J_0(m\rho) e^{-mz} \quad (18)$$

In particular if we wish a solution which is symmetrical about Oz and tends to zero as $\rho \rightarrow 0$ and as $z \rightarrow \infty$, we must take it in the form

$$\psi = \sum_m A_m J_0(m\rho) e^{-mz} \quad (19)$$

Example 5. Find the potential function $\psi(\rho, z)$ in the region $0 \leq \rho \leq 1$, $z \geq 0$ satisfying the conditions

- (i) $\psi \rightarrow 0$ as $z \rightarrow \infty$
- (ii) $\psi = 0$ on $\rho = 1$
- (iii) $\psi = f(\rho)$ on $z = 0$ for $0 \leq \rho \leq 1$

¹ Sneddon, *op. cit.*, equation (15.7).

The conditions (i) and (ii) are satisfied if we take a function of the form

$$\psi(\rho, z) = \sum_x A_x J_0(\lambda_x \rho) e^{-\lambda_x z} \quad (20)$$

where λ_x is a root of the equation

$$J_0(\lambda) = 0$$

Now it is a well-known result of the theory of Bessel functions¹ that we can write

$$f(\rho) = \sum_x A_x J_0(\lambda_x \rho)$$

where

$$A_x = \frac{2}{[J_1(\lambda_x)]^2} \int_0^1 \rho f(\rho) J_0(\lambda_x \rho) d\rho \quad (21)$$

Hence the desired solution is (20), with A_x given by the formula (21).

The method of separation of variables can also be applied to Laplace's equation in rectangular Cartesian coordinates (x, y, z) . It is readily shown that the function

$$\exp(i\alpha x + i\beta y + \gamma z) \quad (22)$$

is a solution of $\nabla^2 \psi$ provided that

$$\gamma^2 = \alpha^2 + \beta^2 \quad (23)$$

The use of solutions of this kind is illustrated by:

Example 6. Find the potential function $\psi(x, y, z)$ in the region $0 \leq x \leq a$, $0 \leq y \leq b$, $0 \leq z \leq c$ satisfying the conditions

(i) $\psi = 0$ on $x = 0$, $x = a$, $y = 0$, $y = b$, $z = 0$

(ii) $\psi = f(x, y)$ on $z = c$, $0 \leq x \leq a$, $0 \leq y \leq b$

The conditions (i) are satisfied if we assume

$$\psi = \sum_m \sum_n A_{mn} \sin \frac{m\pi x}{a} \sin \frac{n\pi y}{b} \sinh(\gamma_{mn} z)$$

where, because of equation (23),

$$\gamma_{mn} = \pi \left(\frac{m^2}{a^2} + \frac{n^2}{b^2} \right)^{1/2} \quad (24)$$

Now by the theory of Fourier series we can write

$$f(x, y) = \sum_{m=1}^{\infty} \sum_{n=1}^{\infty} f_{mn} \sin \frac{m\pi x}{a} \sin \frac{n\pi y}{b}$$

where

$$f_{mn} = \frac{4}{ab} \int_0^a \int_0^b f(x, y) \sin \frac{m\pi x}{a} \sin \frac{n\pi y}{b} dx dy \quad (25)$$

Thus to satisfy (ii) we take

$$A_{mn} = f_{mn} \operatorname{cosech}(\gamma_{mn} c)$$

to obtain the solution

$$\psi(x, y, z) = \sum_{m=1}^{\infty} \sum_{n=1}^{\infty} f_{mn} \sin \frac{m\pi x}{a} \sin \frac{n\pi y}{b} \sinh(\gamma_{mn} z) \operatorname{cosech}(\gamma_{mn} c)$$

where f_{mn} and γ_{mn} are given by equations (25) and (24), respectively.

¹ G. N. Watson, "A Treatise on the Theory of Bessel Functions" 2d. ed. (Cambridge, London, 1944), p. 576.

PROBLEMS

1. If ψ is a harmonic function which is zero on the cone $\theta = \alpha$ and takes the value $\sum_{n=0}^{\infty} x_n r^n$ on the cone $\theta = \beta$, show that when $\alpha < \theta < \beta$,

$$\psi = \sum_{n=0}^{\infty} x_n \left\{ \frac{Q_n(\cos \alpha) P_n(\cos \theta) - P_n(\cos \alpha) Q_n(\cos \theta)}{Q_n(\cos \alpha) P_n(\cos \beta) - P_n(\cos \alpha) Q_n(\cos \beta)} \right\} r^n$$

2. A small magnet of moment m lies at the center of a spherical hollow of radius a in medium of uniform permeability μ . Show that the magnetic field in this medium is the same as that produced by a magnet of moment $3m/(1 - 2\mu)$ lying at the center of the hollow. Determine the field in the hollow.

3. A grounded nearly spherical conductor whose surface has the equation

$$r = a \left(1 + \sum_{n=2}^{\infty} \epsilon_n P_n(\cos \theta) \right)$$

is placed in a uniform electric field E which is parallel to the axis of symmetry of the conductor. Show that if the squares and products of the ϵ 's can be neglected, the potential is given by

$$V = Ea \left\{ \left(1 + \frac{9}{5} \epsilon_2 \right) \left(\frac{a}{r} \right)^2 - \frac{r}{a} \right\} P_1 - 3 \sum_{n=2}^{\infty} \left\{ \frac{n}{2n-1} \epsilon_{n-1} + \frac{n+1}{2n+3} \epsilon_{n-1} \right\} \times \left(\frac{a}{r} \right)^{n+1} P_n \quad \epsilon_1 = 0.$$

4. Heat flows in a semi-infinite rectangular plate, the end $x = 0$ being kept at temperature θ_0 and the long edges $y = 0$ and $y = a$ at zero temperature. Prove that the temperature at a point (x, y) is

$$\frac{4\theta_0}{\pi} \sum_{m=0}^{\infty} \frac{1}{2m+1} \sin \frac{(2m+1)\pi y}{a} e^{-(2m+1)\pi x/a}$$

Handwritten note: $\theta_x = \theta_{yy}$

5. V is a function of r and θ satisfying the equation

$$\frac{\partial^2 V}{\partial r^2} + \frac{1}{r} \frac{\partial V}{\partial r} - \frac{1}{r^2} \frac{\partial^2 V}{\partial \theta^2} = 0$$

within the region of the plane bounded by $r = a$, $r = b$, $\theta = 0$, $\theta = \frac{1}{2}\pi$. Its value along the boundary $r = a$ is $\theta(\frac{1}{2}\pi - \theta)$, and its value along the other boundaries is zero. Prove that

$$V = \frac{2}{\pi} \sum_{n=1}^{\infty} \frac{(r/b)^{4n-2} - (b/r)^{4n-2} \sin(4n-2)\theta}{(a/b)^{4n-2} - (b/a)^{4n-2} (2n-1)^3}$$

Problems with Axial Symmetry

The determination of a potential function ψ for a system which has axial symmetry can often be considerably simplified by making use of a fact that it is sometimes a simple matter to write down the form of ψ

for points on the axis of symmetry. It is best in such cases to use spherical polar coordinates r, θ, ϕ and to take the axis of symmetry to be the polar axis $\theta = 0$. Suppose that we wish to determine the potential function $\psi(r, \theta, \phi)$ corresponding to a given distribution of sources (such as masses, charges, etc.) and that we have been able to calculate its value $\psi(z, 0, 0)$ at a point on the axis of symmetry. If we expand $\psi(z, 0, 0)$ in the Laurent series

$$\psi(z, 0, 0) = \sum_{n=0}^{\infty} \left(A_n z^n + \frac{B_n}{z^{n+1}} \right) \quad (1)$$

then it is readily shown that the required potential function is

$$\psi(r, \theta, \phi) = \sum_{n=0}^{\infty} \left(A_n r^n + \frac{B_n}{r^{n+1}} \right) P_n(\cos \theta) \quad (2)$$

for

- (i) $\nabla^2 \psi = 0$;
- (ii) $\psi(r, \theta, \phi)$ takes the value (1) on the axis of symmetry, since there $P_n(\cos \theta) = 1, r = z$;
- (iii) $\psi(r, \theta, \phi)$ is symmetrical about Oz as required.

The simplest example of the use of this method is the determination of the potential due to a uniform circular wire of radius a charged with electricity of line density e . At a point on the axis of the wire it is readily seen that

$$\psi(z, 0, 0) = \frac{2\pi e a}{\sqrt{a^2 - z^2}}$$

so that
$$\psi(z, 0, 0) = \begin{cases} 2\pi e \sum_{n=0}^{\infty} \frac{\left(\frac{1}{2}\right)_n}{n!} \left(-\frac{z^2}{a^2}\right)^n & z < a \\ 2\pi e \sum_{n=0}^{\infty} \frac{\left(\frac{1}{2}\right)_n}{n!} (-1)^n \left(\frac{a}{z}\right)^{2n+1} & z > a \end{cases}$$

where we have used the notation $(a)_n = a(a+1) \cdots (a+n-1)$.

Hence at a general point we have

$$\psi(r, \theta) = \begin{cases} 2\pi e \sum_{n=0}^{\infty} \frac{\left(\frac{1}{2}\right)_n}{n!} (-1)^n \frac{r^{2n}}{a^{2n}} P_{2n}(\cos \theta) & r \leq a \\ 2\pi e \sum_{n=0}^{\infty} \frac{\left(\frac{1}{2}\right)_n}{n!} (-1)^n \frac{a^{2n+1}}{r^{2n+1}} P_{2n}(\cos \theta) & r \geq a \end{cases}$$

The solution of a direct problem of this kind presents little difficulty. Where the method is most useful is in the combination with that of Sec. 5, as in the following example:

Example 7. A uniform circular wire of radius a charged with electricity of line density e surrounds grounded concentric spherical conductor of radius c . Determine the electrical charge density at any point on the conductor.

By the last result and the method of Sec. 5 we see that we take for the forms of the potential function

$$\psi_1 = 2\pi e \sum_{n=0}^{\infty} \left\{ (-1)^n \frac{\left(\frac{1}{2}\right)_n}{n!} \left(\frac{r}{a}\right)^{2n} \cdot A_n \left(\frac{r}{a}\right)^{2n} + B_n \left(\frac{c}{r}\right)^{2n+1} \right\} P_{2n}(\cos \theta) \quad c < r < a$$

and

$$\psi_2 = 2\pi e \sum_{n=0}^{\infty} \left\{ (-1)^n \frac{\left(\frac{1}{2}\right)_n}{n!} \left(\frac{a}{r}\right)^{2n+1} \cdot C_n \left(\frac{a}{r}\right)^{2n+1} \right\} P_{2n}(\cos \theta) \quad r < a$$

The boundary conditions

$$(i) \quad \psi_1 = 0 \quad \text{on } r = c$$

$$(ii) \quad \psi_1 = \psi_2, \quad \frac{\partial \psi_1}{\partial r} = \frac{\partial \psi_2}{\partial r} \quad \text{on } r = a$$

yield the equations

$$\begin{aligned} (-1)^n \frac{\left(\frac{1}{2}\right)_n}{n!} \left(\frac{c}{a}\right)^{2n} \cdot A_n \left(\frac{c}{a}\right)^{2n} + B_n &= 0 \\ A_n + B_n \left(\frac{c}{a}\right)^{2n+1} &= C_n \\ 2nA_n - (2n+1)B_n \left(\frac{c}{a}\right)^{2n-1} &= -(2n+1)C_n \end{aligned}$$

from which it follows that

$$A_n = 0, \quad B_n = -(-1)^n \frac{\left(\frac{1}{2}\right)_n}{n!} \left(\frac{c}{a}\right)^{2n}$$

Hence when $c < r < a$,

$$\psi_1 = 2\pi e \sum_{n=0}^{\infty} (-1)^n \frac{\left(\frac{1}{2}\right)_n}{n!} \left\{ \frac{r^{2n}}{a^{2n}} - \frac{c^{4n+1}}{a^{2n}r^{2n+1}} \right\} P_{2n}(\cos \theta)$$

The surface density on the spherical conductor is given by the formula

$$\sigma = -\frac{1}{4\pi} \left(\frac{\partial \psi_1}{\partial r} \right)_{r=c}$$

$$\text{so that} \quad \sigma = -\frac{e}{2c} \sum_{n=0}^{\infty} (-1)^n \frac{\left(\frac{1}{2}\right)_n}{n!} (4n+1) \frac{c^{2n}}{a^{2n}} P_{2n}(\cos \theta)$$

PROBLEMS

1. Prove that the potential of a circular disk of radius a carrying a charge of surface density σ at a point $(z, 0, 0)$ on its axis ($\theta = 0$) is

$$2\pi\sigma\{(z^2 + a^2)^{\frac{1}{2}} - z\}$$

Deduce its value at a general point in space.

2. A grounded conducting sphere of radius a has its center on the axis of a charged circular ring, any radius vector \mathbf{c} from this center to the ring making an angle α with the axis. Show that the force pulling the sphere into the ring is

$$-\frac{Q^2}{c^2} \sum_{n=0}^{\infty} (n+1) P_{n+1}(\cos \alpha) P_n(\cos \theta) \left(\frac{a}{c}\right)^{2n-1}$$

3. A grounded conducting sphere of radius a is placed with its center at a point on the axis of a circular coil of radius b at a distance c from the center of the coil; the coil carries a charge e uniformly distributed. Prove that if a is small, the force of attraction between the sphere and the coil is

$$\frac{e^2 ac}{f^4} \left[1 - \frac{a^2}{f^2} \left(\frac{3c^2}{f^2} - 1 \right) \right] = O\left(\frac{a^3}{f^3}\right)$$

where $f^2 = b^2 + c^2$.

4. A dielectric sphere is surrounded by a thin circular wire of large radius b carrying a charge E . Prove that the potential within the sphere is

$$\frac{E}{b} \sum_{n=0}^{\infty} (-1)^n \frac{4n+1}{1+2n(1-\kappa)} \frac{\Gamma(n+\frac{1}{2})}{n!\Gamma(\frac{1}{2})} \left(\frac{r}{b}\right)^{2n} P_{2n}(\cos \theta)$$

7. Kelvin's Inversion Theorem

It is a well-known result in the elementary theory of electrostatics that the solution of certain problems may be derived from that of simpler problems by means of a transformation of three-dimensional space known as inversion in a sphere. The points P, Π with position vectors $\mathbf{r}, \boldsymbol{\rho}$, respectively, are said to be inverse in a sphere S of center

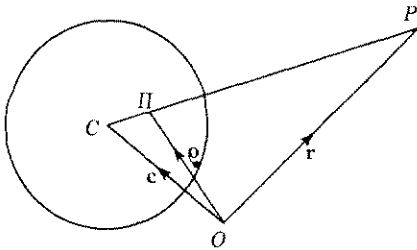

Figure 22

with position vector \mathbf{c} and radius a if the points P, Π, C are collinear and if a is the mean proportional between the distances $CP, C\Pi$. We must therefore have

$$\lambda \mathbf{c} + \mu \mathbf{r} + \nu \boldsymbol{\rho} = \mathbf{0}$$

$$\lambda + \mu + \nu = 1$$

and

$$a^2 = r\rho$$

This transformation has the property that it carries planes or spheres into planes or spheres and carries a sphere S' into itself if and only if S' is orthogonal to S .

We now consider the effect of such a transformation on a harmonic function. If we write $\boldsymbol{\rho} = (\xi, \eta, \zeta)$, $\mathbf{r} = (x, y, z)$, so that

$$\xi = \frac{a^2 x}{r^2}, \quad \eta = \frac{a^2 y}{r^2}, \quad \zeta = \frac{a^2 z}{r^2} \tag{1}$$

then by the well-known rule¹ for the transformation of the Laplacian operator it follows that

$$\nabla^2 \psi = \frac{r^6}{a^6} \left[\frac{\partial}{\partial x} \left(\frac{a^2}{r^2} \frac{\partial \psi}{\partial x} \right) + \frac{\partial}{\partial y} \left(\frac{a^2}{r^2} \frac{\partial \psi}{\partial y} \right) + \frac{\partial}{\partial z} \left(\frac{a^2}{r^2} \frac{\partial \psi}{\partial z} \right) \right] \tag{2}$$

¹ P. M. Morse and H. Feshbach, "Methods of Theoretical Physics" (McGraw-Hill, New York, 1953), pt. 1, p. 115.

Now as a result of direct differentiations it is readily shown that

$$\frac{\partial}{\partial x} \left(\frac{a^2}{r^2} \frac{\partial \psi}{\partial x} \right) = \frac{a}{r} \frac{\partial^2}{\partial x^2} \left(\frac{a}{r} \psi \right) = \frac{a \psi}{r} \frac{\partial^2}{\partial x^2} \left(\frac{a}{r} \right)$$

so that since $1/r$ is a harmonic function, the right-hand side of equation (2) reduces to

$$\frac{r^5}{a^5} \left(\frac{\partial^2}{\partial x^2} + \frac{\partial^2}{\partial y^2} + \frac{\partial^2}{\partial z^2} \right) \left(\frac{a}{r} \psi \right)$$

Hence we have *Kelvin's inversion theorem* that if $\psi(\xi, \eta, \zeta)$ is a harmonic function of ξ, η, ζ in a domain R , then

$$\frac{a}{r} \psi \left(\frac{a^2 x}{r^2}, \frac{a^2 y}{r^2}, \frac{a^2 z}{r^2} \right) = \frac{a}{r} \psi \left(\frac{a^2 \mathbf{r}}{r^2} \right) \quad (3)$$

is a harmonic function of x, y, z in the domain R' into which R is carried by the transformation (1).

By the principle of superposition of solutions of a linear partial differential equation it follows from equation (3) that the functions

$$\frac{1}{r} \int_0^a \lambda \psi_0 \left(\frac{\lambda^2 \mathbf{r}}{r^2} \right) d\lambda, \quad \frac{a}{r} \int_0^1 f(\lambda) \psi_0 \left(\frac{\lambda a^2 \mathbf{r}}{r^2} \right) d\lambda \quad (4)$$

are also solutions of Laplace's equation for any function $f(\lambda)$ such that the second of integrals (4) exists.

Kelvin's inversion method has been adopted by Weiss¹ to yield solutions of potential problems which are neat and readily adaptable to numerical computation. For instance, suppose that $\psi_0(\mathbf{r})$ denotes the potential of an electric field having no singularities within $r = a$ and that a grounded conducting sphere S of radius a is then introduced into the field with its center at the origin. To describe the disturbed field we must find a function ψ satisfying

- (i) $\psi(\mathbf{r}) \sim \psi_0(\mathbf{r})$ for large values of r
- (ii) $\psi = 0$ on $r = a$
- (iii) $\nabla^2 \psi = 0$ for $r > a$

By the above argument it is readily shown that the required function is given by the equation

$$\psi(\mathbf{r}) = \psi_0(\mathbf{r}) - \frac{a}{r} \psi_0 \left(\frac{a^2}{r^2} \mathbf{r} \right) \quad (5)$$

The charge induced on the conducting sphere is

$$\begin{aligned} Q &= -\frac{1}{4\pi} \int_S \left(\frac{\partial \psi}{\partial r} \right)_{r=a} dS \\ &= -\frac{1}{4\pi} \int_S \left(\frac{\partial \psi_0}{\partial r} \right)_{r=a} dS - a \psi_0(\mathbf{0}) \end{aligned}$$

¹ P. Weiss, *Proc. Cambridge Phil. Soc.*, **40**, 259 (1944); *Phil. Mag.*, (7) **38**, 200 (1947).

where $\psi_0(\mathbf{0})$ denotes the value of $\psi_0(\mathbf{r})$ at the origin. Since $\psi_0(\mathbf{r})$ is regular and harmonic within the sphere S , it follows from Gauss' theorem that the first term on the right-hand side of this equation vanishes, and we have

$$Q = -a\psi_0(\mathbf{0}) \quad (6)$$

If the conducting sphere is not grounded but insulated, the solution is

$$\psi(\mathbf{r}) = \psi_0(\mathbf{r}) - \frac{a}{r} \psi_0\left(\frac{a^2\mathbf{r}}{r^2}\right) - \frac{a}{r} \psi_0(\mathbf{0}) \quad (7)$$

In the corresponding hydrodynamical problem we have to determine a function ψ satisfying the conditions

(i) $\psi(\mathbf{r}) \sim \psi_0(\mathbf{r})$ for large values of r

(ii) $\frac{\partial\psi}{\partial r} = 0$ on $r = a$

(iii) $\nabla^2\psi = 0$ for $r > a$

These conditions are satisfied by the function

$$\psi(\mathbf{r}) = \psi_0(\mathbf{r}) + \frac{a}{r} \psi_0\left(\frac{a^2\mathbf{r}}{r^2}\right) - \frac{2}{ar} \int_0^a \lambda \psi_0\left(\frac{\lambda^2\mathbf{r}}{r^2}\right) d\lambda \quad (8)$$

Condition (iii) follows from the fact that if ψ_0 satisfies Laplace's equation, then so do the functions (3) and (4). To verify that condition (i) is satisfied we expand $\psi_0(\mathbf{r})$ into a Taylor series near the origin. We then find that as $r \rightarrow \infty$,

$$\psi(\mathbf{r}) \sim \psi_0(\mathbf{r}) + \psi_0(\mathbf{0}) \left\{ \frac{a}{r} - \frac{2}{ar} \int_0^a \lambda d\lambda \right\} + O(r^{-2})$$

showing that $\psi(r) \sim \psi_0(r)$ as $r \rightarrow \infty$. To prove that condition (ii) is satisfied we note that

$$\begin{aligned} \left(\frac{\partial\psi}{\partial r}\right)_{r=a} &= \left(\frac{\partial\psi_0}{\partial r}\right)_{r=a} - \left[\frac{a}{r^2} \psi_0\left(\frac{a^2\mathbf{r}}{r^2}\right) + \frac{a^3}{r^4} (\mathbf{r} \cdot \text{grad } \psi_0)\right]_{r=a} \\ &\quad + \frac{2}{a} \int_0^a \left[\frac{\lambda}{r^2} \psi_0\left(\frac{\lambda^2\mathbf{r}}{r^2}\right) + \frac{\lambda^3}{r^4} (\mathbf{r} \cdot \text{grad } \psi_0)\right]_{r=a} d\lambda \\ &= \left(\frac{\partial\psi_0}{\partial r}\right)_{r=a} - \frac{1}{a} \psi_0(\mathbf{r}) - \frac{1}{a} (\mathbf{r} \cdot \text{grad } \psi_0) \\ &\quad + \frac{1}{a} \int_0^a \frac{d}{d\lambda} \left[\frac{\lambda^2}{a^2} \psi_0\left(\frac{\lambda^2\mathbf{r}}{a^2}\right)\right] d\lambda \\ &= \left(\frac{\partial\psi_0}{\partial r}\right)_{r=a} - \frac{1}{a} (\mathbf{r} \cdot \text{grad } \psi_0) \\ &= 0 \end{aligned}$$

The results obtained by means of Kelvin's inversion theorem may be given a quasi-physical interpretation through the language of the method of images well known in the elementary theory of electrostatics. The "image system" of the problem whose solution is given by equation (5) is the distribution of electric charge which leads to a potential

$$-\frac{a}{r} \psi_0 \left(\frac{a^2}{r^2} \mathbf{r} \right)$$

PROBLEMS

1. A grounded conducting sphere of radius a is placed at the origin in an electric field whose electrostatic potential in the undisturbed state is $V_n(x, y, z)$, a homogeneous function of degree n in x, y, z . Show that the electrostatic potential is now given by the equation

$$\psi = \left(1 - \frac{a^{2n+1}}{r^{2n+1}} \right) V_n(x, y, z)$$

Hence determine the electrostatic potential of the field surrounding a grounded conducting sphere placed in a uniform electric field of strength E .

2. A point charge q is placed at a point with position vector \mathbf{f} outside a grounded conducting sphere of radius a . Find the electrostatic potential of the field, and show that the image system consists of a charge $-qa/f$ situated at the inverse point $a^2\mathbf{f}/f^2$.
3. If the velocity potential of the undisturbed flow of a perfect fluid $V_n(x, y, z)$ is a homogeneous function of x, y, z of degree n , show that the velocity potential of the disturbed flow due to the insertion of a sphere of radius a at the origin is

$$\psi = \left(1 - \frac{n}{n+1} \frac{a^{2n+1}}{r^{2n+1}} \right) V_n(x, y, z)$$

Deduce the velocity potential corresponding to the flow of a perfect fluid round a sphere placed in a uniform stream.

4. A sphere of radius a is placed at the origin in the fluid flow produced by a point source of strength m situated at the point with position vector \mathbf{f} ($f > a$). Determine the velocity potential and show that the image system consists of a source ma/f at the point $\mathbf{f}' = a^2\mathbf{f}/f^2$ and a uniform sink of line density m/a extending from the origin to the point \mathbf{f}' .

8. The Theory of Green's Function for Laplace's Equation

We return now to the consideration of the interior Dirichlet problem formulated in Sec. 4. Suppose, in the first instance, that the values of ψ and $\partial\psi/\partial n$ are known at every point of the boundary S of a finite region V and that $\nabla^2\psi = 0$ within V . We can then determine ψ by a simple application of Green's theorem in the form (Lass, *loc. cit.*)

$$\int_{\Omega} (\psi \nabla^2 \psi' - \psi' \nabla^2 \psi) d\tau = \int_{\Sigma} \left(\psi \frac{\partial \psi'}{\partial n} - \psi' \frac{\partial \psi}{\partial n} \right) dS \quad (1)$$

where Σ denotes the boundary of the region Ω .

If we are interested in determining the solution $\psi(\mathbf{r})$ of our problem at a point P with position vector \mathbf{r} , then we surround P by a sphere C which has its center at P and has radius ϵ (cf. Fig. 23) and take Σ to be the region which is exterior to C and interior to S . Putting

$$\psi' = \frac{1}{|\mathbf{r}' - \mathbf{r}|}$$

and noting that

$$\nabla^2 \psi' = \nabla^2 \psi = 0$$

within Ω , we see that

$$\begin{aligned} & \int_C \left\{ \psi(\mathbf{r}') \frac{\partial}{\partial n} \frac{1}{|\mathbf{r}' - \mathbf{r}|} \right. \\ & \quad \left. - \frac{1}{|\mathbf{r}' - \mathbf{r}|} \frac{\partial \psi}{\partial n} \right\} dS' \\ & + \int_S \left\{ \psi(\mathbf{r}') \frac{\partial}{\partial n} \frac{1}{|\mathbf{r}' - \mathbf{r}|} \right. \\ & \quad \left. - \frac{1}{|\mathbf{r}' - \mathbf{r}|} \frac{\partial \psi}{\partial n} \right\} dS' = 0 \quad (2) \end{aligned}$$

where the normals \mathbf{n} are in the directions shown in Fig. 23. Now, on the surface of the sphere C ,

$$\frac{1}{|\mathbf{r}' - \mathbf{r}|} = \frac{1}{\epsilon}, \quad \frac{\partial}{\partial n} \frac{1}{|\mathbf{r}' - \mathbf{r}|} = \frac{1}{\epsilon^2};$$

$$dS' = \epsilon^2 \sin \theta \, d\theta \, d\phi$$

and
$$\psi(\mathbf{r}') = \psi(\mathbf{r}) + \epsilon \left\{ \sin \theta \cos \phi \frac{\partial \psi}{\partial x} + \sin \theta \sin \phi \frac{\partial \psi}{\partial y} + \cos \theta \frac{\partial \psi}{\partial z} \right\}$$

$$\frac{\partial \psi}{\partial n} = \left(\frac{\partial \psi}{\partial n} \right)_P + O(\epsilon)$$

so that
$$\int_C \psi(\mathbf{r}') \frac{\partial}{\partial n} \frac{1}{|\mathbf{r}' - \mathbf{r}|} dS' = 4\pi \psi(\mathbf{r}) + O(\epsilon)$$

and
$$\int_C \frac{1}{|\mathbf{r}' - \mathbf{r}|} \frac{\partial \psi}{\partial n} dS' = O(\epsilon)$$

Substituting these results into equation (2) and letting ϵ tend to zero, we find that

$$\psi(\mathbf{r}) = \frac{1}{4\pi} \int_S \left\{ \frac{1}{|\mathbf{r}' - \mathbf{r}|} \frac{\partial \psi(\mathbf{r}')}{\partial n} - \psi(\mathbf{r}') \frac{\partial}{\partial n} \frac{1}{|\mathbf{r}' - \mathbf{r}|} \right\} dS' \quad (3)$$

so that the value of ψ at an interior point of the region V can be determined in terms of the values of ψ and $\partial\psi/\partial n$ on the boundary S .

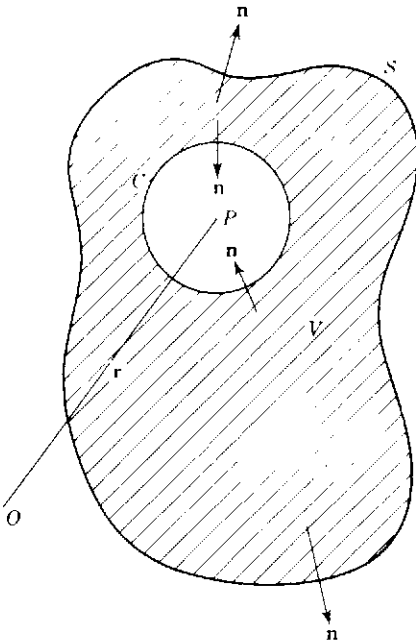

Figure 23

A similar result holds in the case of the exterior Dirichlet problem. In this case we take the region Ω occurring in equation (1) to be the region bounded by S , a small sphere C surrounding P , and Σ' a sphere with center the origin and large radius R (cf. Fig. 24). Taking the directions of the normals to be as indicated in Fig. 24 and proceeding as above, we find, in this instance, that

$$4\pi\psi(\mathbf{r}) + O(\epsilon) = \int_S \left\{ \frac{1}{|\mathbf{r}' - \mathbf{r}|} \frac{\partial\psi(\mathbf{r}')}{\partial n} - \psi(\mathbf{r}') \frac{\partial}{\partial n} \frac{1}{|\mathbf{r}' - \mathbf{r}|} \right\} dS' \\ - \int_{\Sigma'} \left\{ \frac{1}{R} \frac{\partial\psi}{\partial n} - \frac{\psi}{R^2} \right\} dS' = 0$$

Letting $\epsilon \rightarrow 0$ and $R \rightarrow \infty$, we see that the solution (3) is valid in the case of the exterior Dirichlet problem provided that $R\psi$ and $R^2 \partial\psi/\partial n$ remain finite as $R \rightarrow \infty$. This explains the remark made in sec. 4.

Equation (3) would seem at first sight to indicate that to obtain a solution of Dirichlet's problem we need to know not only the value of the function ψ but also the value of $\partial\psi/\partial n$. That this is not the case so can be shown by the introduction of the concept of a Green's function. We define a Green's function $G(\mathbf{r}, \mathbf{r}')$ by the relation

$$G(\mathbf{r}, \mathbf{r}') = H(\mathbf{r}, \mathbf{r}') + \frac{1}{|\mathbf{r}' - \mathbf{r}|} \quad (4)$$

where the function $H(\mathbf{r}, \mathbf{r}')$ satisfies the relations

$$\left(\frac{\partial^2}{\partial x'^2} + \frac{\partial^2}{\partial y'^2} + \frac{\partial^2}{\partial z'^2} \right) H(\mathbf{r}, \mathbf{r}') = 0 \quad (5)$$

$$H(\mathbf{r}, \mathbf{r}') + \frac{1}{|\mathbf{r}' - \mathbf{r}|} = 0 \quad \text{on } S \quad (6)$$

Then since, just as in the derivation of equation (3), we can show that

$$\psi(\mathbf{r}) = -\frac{1}{4\pi} \int_S \left\{ G(\mathbf{r}, \mathbf{r}') \frac{\partial\psi(\mathbf{r}')}{\partial n} - \psi(\mathbf{r}') \frac{\partial G(\mathbf{r}, \mathbf{r}')}{\partial n} \right\} dS' \quad (7)$$

it follows that if we have found a function $G(\mathbf{r}, \mathbf{r}')$ satisfying equations (5), and (6), then the solution of the Dirichlet problem is given by the relation

$$\psi(\mathbf{r}) = -\frac{1}{4\pi} \int_S \psi(\mathbf{r}') \frac{\partial G(\mathbf{r}, \mathbf{r}')}{\partial n} dS' \quad (8)$$

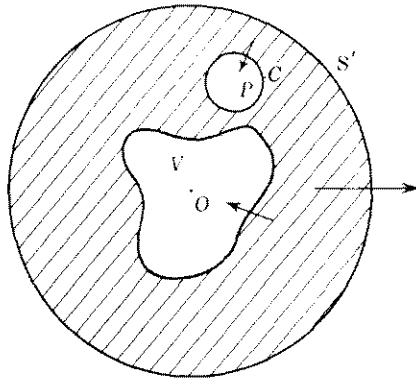

Figure 24

The solution of the Dirichlet problem is thus reduced to the determination of the Green's function $G(\mathbf{r}, \mathbf{r}')$.

It is readily shown (Prob. 1 below) that the Green's function $G(\mathbf{r}, \mathbf{r}')$ has the property of symmetry

$$G(\mathbf{r}_1, \mathbf{r}_2) = G(\mathbf{r}_2, \mathbf{r}_1) \quad (9)$$

i.e., if P_1 and P_2 are two points within a finite region bounded by a surface S , then the value at P_2 of the Green's function for the point P_1 and the surface S is equal to the value at P_1 of the Green's function for the point P_2 and the surface S .

The physical interpretation of the Green's function is obvious. If S is a grounded electrical conductor and if a unit charge is situated at the point with radius vector \mathbf{r} , then

$$G(\mathbf{r}, \mathbf{r}') = \frac{1}{|\mathbf{r} - \mathbf{r}'|} + H(\mathbf{r}, \mathbf{r}')$$

is the value at the point \mathbf{r}' of the potential due to the charge at \mathbf{r} and the induced charge on S . The first term on the right of this equation is the potential of the unit charge, and the second is the potential of the induced charge. By the definition of $H(\mathbf{r}, \mathbf{r}')$ the total potential $G(\mathbf{r}, \mathbf{r}')$ vanishes on S .

We shall conclude this section by deriving the Green's function appropriate to two important cases of Dirichlet's problem.

(a) *Dirichlet's Problem for a Semi-infinite Space.* If we take the semi-infinite space to be $x \geq 0$, then we have to determine a function ψ such that $\nabla^2 \psi = 0$ in $x \geq 0$, $\psi = f(y, z)$ on $x = 0$, and $\psi \rightarrow 0$ as $r \rightarrow \infty$. The corresponding conditions on the Green's function $G(\mathbf{r}, \mathbf{r}')$ are that equations (4) and (5) should be satisfied and that G should vanish on the plane $x = 0$.

Suppose that Π , with position vector $\boldsymbol{\rho}$, is the image in the plane $x = 0$ of the point P with position vector \mathbf{r} (cf. Fig. 25). If we take

$$H(\mathbf{r}, \mathbf{r}') = -\frac{1}{|\boldsymbol{\rho} - \mathbf{r}'|} \quad (10)$$

then it is obvious that equation (5) is satisfied. Since $PQ = \Pi Q$ whenever Q lies on $x = 0$, it follows that equation (6) is also satisfied.

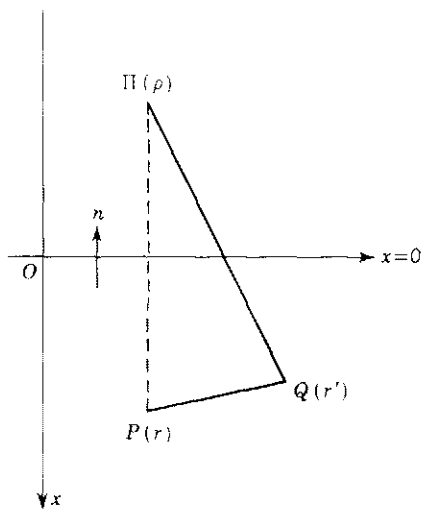

Figure 25

The required Green's function is therefore given by the equation

$$G(\mathbf{r}, \mathbf{r}') = \frac{1}{|\mathbf{r} - \mathbf{r}'|} - \frac{1}{|\boldsymbol{\rho} - \mathbf{r}'|} \quad (11)$$

where, if $\mathbf{r} = (x, y, z)$, $\boldsymbol{\rho} = (-x, y, z)$.

The solution of the Dirichlet problem follows immediately from equation (8). Since

$$\frac{\partial G(\mathbf{r}, \mathbf{r}')}{\partial n} = -\frac{\partial}{\partial x'} \left[\frac{1}{\sqrt{(x - x')^2 + (y - y')^2 + (z - z')^2}} - \frac{1}{\sqrt{(x + x')^2 + (y - y')^2 + (z - z')^2}} \right]$$

it follows that on the plane $x' = 0$

$$\frac{\partial G(\mathbf{r}, \mathbf{r}')}{\partial n} = -\frac{2x}{[x^2 + (y - y')^2 + (z - z')^2]^{3/2}}$$

Substituting this result and $\psi(\mathbf{r}') = f(y', z')$ into equation (8), we find that the solution of this Dirichlet problem is given by the formula

$$\psi(x, y, z) = \frac{x}{2\pi} \int_{-x}^x \int_{-x}^x \frac{f(y', z') dy' dz'}{[x^2 + (y - y')^2 + (z - z')^2]^{3/2}} \quad (12)$$

(b) *Dirichlet's Problem for a Sphere.* We shall consider the interior Dirichlet problem for a sphere, i.e., the determination of a function $\psi(r, \theta, \phi)$ satisfying the conditions

$$\nabla^2 \psi = 0 \quad r < a \quad (13)$$

$$\psi = f(\theta, \phi) \quad \text{on } r = a \quad (14)$$

The corresponding conditions on the Green's function $G(\mathbf{r}, \mathbf{r}')$ are that equations (4) and (5) should be satisfied and that G should vanish on the surface of the sphere $r = a$.

Suppose that Π , with position vector $\boldsymbol{\rho}$, is the inverse point with respect to the sphere $r = a$ of the point P with position vector \mathbf{r} (cf. Fig. 26). Then if we take

$$H(\mathbf{r}, \mathbf{r}') = -\frac{a}{r|\boldsymbol{\rho} - \mathbf{r}'|} = -\frac{a}{r \left| \frac{a^2}{r^2} \mathbf{r} - \mathbf{r}' \right|} \quad (15)$$

it is obvious that equation (5) is satisfied, and it is a well-known proposition of elementary geometry that if Q lies on the surface of the sphere, $PQ = (r/a)\Pi Q$, so that equation (6) is also satisfied. The Green's function appropriate to this problem is therefore given by the equation

$$G(\mathbf{r}, \mathbf{r}') = \frac{1}{|\mathbf{r} - \mathbf{r}'|} - \frac{a/r}{\left| \frac{a^2}{r^2} \mathbf{r} - \mathbf{r}' \right|} \quad (16)$$

Now
$$\frac{\partial G}{\partial r'} = \frac{1}{R^3} \left(R \frac{\partial R}{\partial r'} - \frac{r^2}{a^2} R' \frac{\partial R'}{\partial r'} \right)$$

where $R^2 = r^2 + r'^2 - 2rr' \cos \Theta$, $R'^2 = \frac{a^4}{r^2} + r'^2 - \frac{2a^2}{r} r' \cos \Theta$ (17)

and $\cos \Theta = \cos \theta \cos \theta' + \sin \theta \sin \theta' \cos(\phi - \phi')$ (18)

Thus
$$\frac{\partial G}{\partial r'} = -\frac{r'(a^2 - r^2)}{a^2 R^3}$$

and when $r' = a$,

$$\frac{\partial G}{\partial n} = \frac{\partial G}{\partial r'} = -\frac{a^2 - r^2}{a(r^2 + a^2 - 2ar \cos \theta)^{3/2}} \quad (19)$$

Hence if $\psi = f(\theta, \phi)$ on $r = a$, it follows from equations (8) and (19)

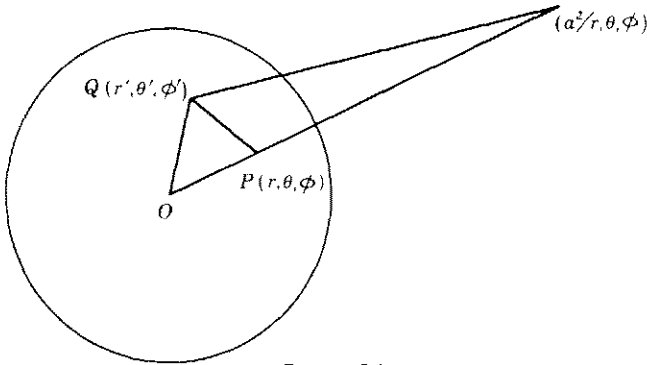

Figure 26

that the solution of the interior Dirichlet problem for a sphere is given by the equation

$$\psi(r, \theta, \phi) = \frac{a(a^2 - r^2)}{4\pi} \int_0^{2\pi} d\phi' \int_0^\pi \frac{f(\theta', \phi') \sin \theta' d\theta'}{(a^2 + r^2 - 2ar \cos \Theta)^{3/2}} \quad (20)$$

where $\cos \Theta$ is defined by equation (18).

Making use of the result of Prob. 4 of Sec. 4, we see that the solution of the corresponding exterior Dirichlet problem is

$$\psi(r, \theta, \phi) = \frac{a(r^2 - a^2)}{4\pi} \int_0^{2\pi} d\phi' \int_0^\pi \frac{f(\theta', \phi') \sin \theta' d\theta'}{(a^2 + r^2 - 2ar \cos \Theta)^{3/2}} \quad (21)$$

The integral on the right-hand side of the solution (20) of the interior Dirichlet problem is called *Poisson's integral*. It is interesting to note that Poisson's solution of this problem can also be obtained by means of the method of separation of variables outlined in Sec. 5. The function

$$\psi(r, \theta, \phi) = \sum_{n=0}^{\infty} \left(\frac{r}{a}\right)^n \left\{ \sum_{m=0}^{\infty} (A_{mn} \cos m\phi + B_{mn} \sin m\phi) P_n^m(\cos \theta) \right\} \quad (22)$$

is a solution of Laplace's equation which is finite at the origin. If this function is to provide a solution of our interior Dirichlet problem, then the constants A_{mn} , B_{mn} must be chosen so that

$$f(\theta, \phi) = \sum_{n=0}^{\infty} \sum_{m=0}^n (A_{mn} \cos m\phi - B_{mn} \sin m\phi) P_n^m(\cos \theta)$$

It is known from the theory of Legendre functions that we must then take

$$A_{0n} = \frac{2n+1}{4\pi} \int_{-\pi}^{\pi} \int_0^{\pi} f(\theta', \phi') P_n(\cos \theta') \sin \theta' d\theta' d\phi'$$

$$A_{mn} = \frac{(2n-1)(n-m)!}{2\pi(n+m)!} \int_{-\pi}^{\pi} \int_0^{\pi} f(\theta', \phi') P_n^m(\cos \theta') \sin \theta' \cos(m\phi') d\theta' d\phi'$$

$$B_{mn} = \frac{(2n+1)(n-m)!}{2\pi(n+m)!} \int_{-\pi}^{\pi} \int_0^{\pi} f(\theta', \phi') P_n^m(\cos \theta') \sin \theta' \sin(m\phi') d\theta' d\phi'$$

Substituting these expressions into equation (22) and interchanging the orders of summation and integration, we find that

$$\psi(r, \theta, \phi) = \frac{1}{4\pi} \int_{-\pi}^{\pi} \int_0^{\pi} f(\theta', \phi') g \sin \theta' d\theta' d\phi' \quad (23)$$

where

$$g = \sum_{n=0}^{\infty} (2n+1) \left(\frac{r}{a}\right)^n \left\{ P_n(\cos \theta) P_n(\cos \theta') \right. \\ \left. + 2 \sum_{m=1}^n \left(\frac{(n-m)!}{(n+m)!}\right) P_n^m(\cos \theta) P_n^m(\cos \theta') \cos m(\phi - \phi') \right\}$$

From the well-known relations

$$\frac{1-h^2}{(1-2h \cos \Theta + h^2)^{3/2}} = \sum_{n=0}^{\infty} (2n+1) h^n P_n(\cos \Theta)$$

$$P(\cos \Theta) = P_n(\cos \theta) P_n(\cos \theta') + 2 \sum_{m=1}^n \frac{(n-m)!}{(n+m)!} P_n^m(\cos \theta) \\ \times P_n^m(\cos \theta') \cos m(\phi - \phi')$$

where Θ is defined by equation (18), we see that

$$g = \frac{a(a^2 - r^2)}{(a^2 - 2ar \cos \Theta + r^2)^{3/2}} \quad (24)$$

Substituting from equation (24) into equation (23), we obtain Poisson's solution (21).

PROBLEMS

1. Suppose that P_1 and P_2 are two points with position vectors \mathbf{r}_1 and \mathbf{r}_2 , respectively, which lie in the interior of a finite region V bounded by a surface S . By applying Green's theorem in the form (1) to the region bounded by S and two spheres of small radii surrounding P_1 and P_2 and taking $\psi(\mathbf{r}') = G(\mathbf{r}_1, \mathbf{r}')$, $\psi'(\mathbf{r}') = G(\mathbf{r}_2, \mathbf{r}')$, prove that

$$G(\mathbf{r}_1, \mathbf{r}_2) = G(\mathbf{r}_2, \mathbf{r}_1)$$

2. If the function $\psi(x, y, z)$ is harmonic in the half space $x \geq 0$, and if on $x = 0$, $\psi = 1$ inside a closed curve C and $\psi = 0$ outside C , prove that $2\pi\psi(x, y, z)$ is equal to the solid angle subtended by C at the point with coordinates (x, y, z) .
3. If $\psi(x, y, z)$ is such that $\nabla^2\psi = 0$ for $x \geq 0$, $\psi = f(y)$ on $x = 0$, and $\psi \rightarrow 0$ as $r \rightarrow \infty$, prove that

$$\psi(x, y, z) = \frac{x}{\pi} \int_{-\infty}^{\infty} \frac{f(y') dy'}{x^2 + (y - y')^2}$$

4. The function $\psi(\mathbf{r})$ is harmonic within a sphere S and is continuous on the boundary. Prove that the value of ψ at the center of the sphere is equal to the arithmetic mean of its values on the surface of the sphere.
5. Use Green's theorem to show that, in a usual notation, if at all points of space

$$\nabla^2\phi = -4\pi\rho$$

where ρ is a function of position, and if ϕ and $r \text{ grad } \phi$ tend to zero at infinity, then

$$\phi = \int \frac{\rho dV}{r}$$

9. The Relation of Dirichlet's Problem to the Calculus of Variations

The interior Dirichlet problem is closely related to a problem in the calculus of variations. It is a well-known result in the calculus of variations¹ that the function $\psi(x, y, z)$, which makes the volume integral

$$\int_V F(x, y, z, \psi, \psi_x, \psi_y, \psi_z) d\tau \quad (1)$$

an extremum with respect to twice-differentiable functions which assume prescribed values at all points of the boundary surface S of V , must satisfy the Euler-Lagrange differential equation

$$\frac{\partial F}{\partial \psi} = \frac{\partial}{\partial x} \left(\frac{\partial F}{\partial \psi_x} \right) + \frac{\partial}{\partial y} \left(\frac{\partial F}{\partial \psi_y} \right) + \frac{\partial}{\partial z} \left(\frac{\partial F}{\partial \psi_z} \right) \quad (2)$$

It follows from this result that the function, among all the functions which have continuous second derivatives in V and on S and take on the prescribed values f on S , which makes the integral

$$I(\psi) = \int_V (\text{grad } \psi)^2 d\tau \quad (3)$$

¹ R. Weinstock, "Calculus of Variations" (McGraw-Hill, New York, 1952) pp. 132-135.

an extremum is the solution of the Dirichlet problem

$$\nabla^2 \psi = 0 \text{ within } V, \quad \psi = f \text{ on } S \quad (4)$$

The Dirichlet variational problem, that of minimizing the integral (3) subject to the conditions stated, and the interior Dirichlet problem are therefore equivalent problems. If a solution exists, then they have the same solution.

Since I is always positive, the integrals $I(\psi)$ formed for admissible functions ψ are a set of positive numbers which has a lower bound, from which Riemann deduced the existence of a function making the integral a minimum.¹ It was pointed out by Weierstrass that Riemann's argument was unsound, and he gave an example for which no solution existed, but Hilbert showed later that provided certain limiting conditions on S and on f are satisfied, Dirichlet's variational problem always possesses a solution. The value of the method lies in the fact that in certain cases "direct methods," i.e., methods which do not reduce the variational problem to one in differential equations, may produce a solution of the variational problem more easily than the classical methods could produce a solution of the interior Dirichlet problem. The variational method is also of great value in providing approximate solutions, especially in certain physical problems in which the minimum value of I is the object of most interest; e.g., in electrostatic problems, I is closely related to the capacity of the system.

10. "Mixed" Boundary Value Problems

In the problems of Dirichlet, Neumann, and Churchill the function ψ or its normal derivative $\partial\psi/\partial n$ or a linear combination of them is prescribed over the entire surface S bounding the region V in which $\nabla^2\psi = 0$. In "mixed" boundary value problems conditions of different types are satisfied at various regions of S . A typical problem of this kind is illustrated in Fig. 27. In this problem we have to determine a function ψ which satisfies

$$\begin{aligned} \text{(i)} \quad & \nabla^2 \psi = 0 && \text{within } V \\ \text{(ii)} \quad & \psi = f && \text{on } S_1 \\ \text{(iii)} \quad & \frac{\partial \psi}{\partial n} = g && \text{on } S_2 \end{aligned}$$

where $S_1 \cup S_2 = S$, the boundary of V , and the functions f and g are prescribed.

As an example of a boundary value problem of this type consider the classical problem of an electrified disk.² If, in polar coordinates

¹ This is known as Dirichlet's principle.

² G. Green, "Mathematical Papers" (Cambridge, London, 1871), p. 172.

(ρ, ϕ, z) , $\psi(\rho, \phi, z)$ is the potential due to a perfectly conducting uniform thin circular disk of unit radius which is kept at a prescribed potential, then the boundary value problem to be solved is

$$\frac{\partial^2 \psi}{\partial \rho^2} + \frac{1}{\rho} \frac{\partial \psi}{\partial \rho} + \frac{\partial^2 \psi}{\partial z^2} + \frac{1}{\rho^2} \frac{\partial^2 \psi}{\partial \phi^2} = 0 \quad (1)$$

$$\psi = g(\rho, \phi) \quad \text{on } z = 0, 0 < \rho < 1 \quad (2)$$

$$\frac{\partial \psi}{\partial z} = 0 \quad \text{on } z = 0, \rho > 1 \quad (3)$$

In equation (2) the function $g(\rho)$ is prescribed. This equation expresses the fact that the potential is prescribed on the surface of the disk, while the equation (3) is equivalent to assuming that there is no surface density of charge outside the disk. The problem is to determine ψ or, more usually, to find the surface of the disk. It is also assumed

that $\psi \rightarrow 0$ as $\sqrt{r^2 + z^2} \rightarrow \infty$.

Suppose that

$$g(\rho, \phi) = G(\rho) \cos n(\phi - \epsilon) \quad (4)$$

Then we may write $\psi = \Psi(\rho, z) \cos n(\phi - \epsilon)$, where

$$\frac{\partial^2 \Psi}{\partial \rho^2} + \frac{1}{\rho} \frac{\partial \Psi}{\partial \rho} - \frac{n^2}{\rho^2} \Psi + \frac{\partial^2 \Psi}{\partial z^2} = 0 \quad (5)$$

and

$$\Psi = G(\rho) \quad \text{on } z = 0, 0 < \rho < 1 \quad (6)$$

$$\frac{\partial \Psi}{\partial z} = 0 \quad \text{on } z = 0, \rho > 1 \quad (7)$$

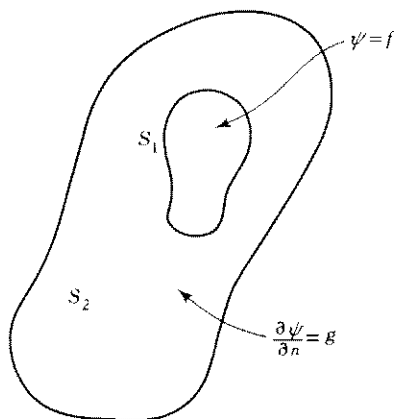

Figure 27

The form (4) is more general than it appears, since it is possible to derive a solution for functions of type $g(\rho, \phi)$ by a Fourier superposition of functions of type (4).

To derive a solution of equation (5) we note that

$$e^{-|z|} J_n(\rho t)$$

is a solution of the equation. By the superposition principle it follows that

$$\Psi(\rho, z) = \int_0^\infty f(t) e^{-|z|} J_n(\rho t) dt \quad (8)$$

is also a solution for any arbitrary $f(t)$ such that the integral on the right exists. Substituting from equation (8) into equations (6) and (7)

we see that the function $f(t)$ is determined by the pair of dual integral equations

$$\int_0^\infty f(t)J_n(\rho t) dt = G(\rho) \quad 0 < \rho < 1 \quad (9)$$

$$\int_0^\infty tf(t)J_n(\rho t) dt = 0 \quad \rho > 1 \quad (10)$$

Using the fact that

$$\left(\frac{\partial \psi}{\partial z}\right)_{z=0} - \left(\frac{\partial \psi}{\partial z}\right)_{z=0} = 4\pi\sigma = 0$$

we see that the total surface density σ on the two faces of the disk is $s(\rho) \cos n(\phi - \epsilon)$, where

$$s(\rho) = \frac{1}{2\pi} \int_0^\infty tf(t)J_n(\rho t) dt \quad (11)$$

A general solution of the dual integral equations (9) and (10) has been given by Titchmarsh.¹ It is found that

$$f(t) = \sqrt{\frac{2}{\pi}} \left[t^{\frac{1}{2}} J_{n-\frac{1}{2}}(t) \int_0^1 \frac{y^{n+1} G(y) dy}{\sqrt{1-y^2}} + \int_0^1 \frac{u^{n+1} du}{\sqrt{1-u^2}} \int_0^1 G(yu)(ty)^{\frac{1}{2}} J_{n-\frac{1}{2}}(ty) dy \right] \quad (12)$$

Substituting from equation (12) into equation (11), we then get the expression for $s(\rho)$.

Solutions of the dual integral equations (9) and (10) in various special cases had been given prior to Titchmarsh's analysis by Weber [$n = 0$, $G(\rho)$ constant], Gallop [$n = 0$, $G(\rho) = J_0(c\rho)$], Basset [$n = 1$, $G(\rho) = J_1(c\rho)$], MacDonald [n arbitrary, $G(\rho) = J_n(c\rho)$], and King [n integral, $G(\rho)$ arbitrary].

In all the cases considered the analysis was difficult and long, but the surprising thing was that the final results were simple. This suggested to Copson² that we might give a simpler derivation of the solution by starting with a more suitable form of potential function. Copson took, instead of the form (8), the form

$$\psi = \int_0^1 \int_0^{2\pi} \frac{\sigma(\rho', \phi') \rho' d\phi' d\rho'}{r} \quad (13)$$

where r is the distance of a general point (ρ, ϕ, z) from a point $(\rho', \phi', 0)$ on the disk. To give the correct boundary conditions on $z = 0$ we

¹ F. C. Titchmarsh, "Introduction to the Theory of Fourier Integrals" (Oxford, New York, 1937), p. 334. The form of solution given here is due to I. W. Busbridge, *Proc. London Math. Soc.*, **44**, 115 (1938).

² E. T. Copson, *Proc. Edinburgh Math. Soc.*, (iii) **8**, 14 (1947).

must have $\sigma(\rho', \phi') = s(\rho') \cos n(\phi' - \epsilon)$, where $s(\rho')$ is chosen so that

$$\int_0^1 s(\rho') \rho' d\rho' \int_0^{2\pi} \frac{\cos n(\phi' - \epsilon) d\phi'}{\sqrt{\rho'^2 + \rho'^2} \cdot 2\rho\rho' \cos(\phi' - \phi)} = G(\rho) \cos n(\phi - \epsilon) \quad (14)$$

when $0 < \rho < 1$.

Now it is readily shown (cf. Prob. 1 below) that the inner integral has the value

$$\frac{4 \cos n(\phi - \epsilon)}{(\rho\rho')^n} \int_0^{\min(\rho, \rho')} \frac{t^{2n} dt}{\sqrt{(\rho'^2 - t^2)(\rho^2 - t^2)}}$$

so that equation (14) becomes

$$\frac{4}{\rho^n} \left[\int_0^\rho s(\rho') (\rho')^{1-n} du \int_0^{\rho'} \frac{t^{2n} dt}{\sqrt{(\rho'^2 - t^2)(\rho^2 - t^2)}} + \int_\rho^1 s(\rho') (\rho')^{1-n} d\rho' \int_0^\rho \frac{t^{2n} dt}{\sqrt{(\rho'^2 - t^2)(\rho^2 - t^2)}} \right] = G(\rho)$$

Inverting the order of integration, we find that

$$\frac{1}{4} \rho^n G(\rho) = \int_0^\rho \frac{t^{2n} dt}{\sqrt{\rho^2 - t^2}} \int_t^1 \frac{s(\rho') \rho'^{1-n} d\rho'}{\sqrt{\rho'^2 - t^2}} \quad 0 < \rho < 1 \quad (15)$$

To solve equation (15) we let

$$S(\rho) = \int_\rho^1 \frac{s(\rho') \rho'^{1-n} d\rho'}{\sqrt{\rho'^2 - \rho^2}} \quad 0 < \rho < 1 \quad (16)$$

and obtain

$$\frac{1}{4} \rho^n G(\rho) = \int_0^\rho \frac{t^{2n} S(t) dt}{\sqrt{\rho^2 - t^2}} \quad 0 < \rho < 1 \quad (17)$$

If $G(\rho)$, $G'(\rho)$ are continuous, it follows by a trivial transformation of the well-known solution of Abel's integral equation¹ (cf. Prob. 2 below) that

$$S(\rho) = \frac{1}{2\pi\rho^{2n}} \frac{d}{d\rho} \int_0^\rho \frac{t^{n+1} G(t) dt}{\sqrt{\rho^2 - t^2}} \quad (18)$$

It only remains to derive the expression for $s(\rho)$ from this expression for $S(\rho)$. If $S(\rho)$ and its first derivative are continuous in any closed interval $[\eta, 1]$ for any positive value of $\eta < 1$, then, by an application of the solution of Abel's integral equation (cf. Prob. 3 below), we have

$$s(\rho) = -\frac{2}{\pi} \rho^{n-1} \frac{d}{d\rho} \int_\rho^1 \frac{t S(t) dt}{\sqrt{t^2 - \rho^2}} \quad 0 < \rho < 1 \quad (19)$$

which solves the problem.

¹ M. Bocher, "An Introduction to the Study of Integral Equations" (Cambridge, London, 1929), p. 8.

Hence we have:

Copson's Theorem. *If the potential on the surface of the circular disk $z = 0$, $0 < \rho < 1$ is $G(\rho) \cos n(\phi - \epsilon)$, where ϵ is a constant, n is zero or a positive integer, and $G(\rho)$ is continuously differentiable in $0 < \rho < 1$, then if $S(\rho)$, defined by (18), is continuously differentiable in $[\eta, 1]$ for any positive $\eta < 1$, the surface density of electric charge on the surface of the disk is $s(\rho) \cos n(\phi - \epsilon)$, where $s(\rho)$ is defined by equation (19).*

Example 8. *Find the surface density of charge on a disk raised to unit potential with no external field.*

Here $\tau = 0$, and $G(\rho) = 1$.

(a) *Dual Integral Equation Method.* From equation (12) we find that

$$f(t) = \frac{2 \sin t}{\pi t}$$

so that, by equation (11),

$$s(\rho) = \frac{1}{\pi^2} \int_0^\infty \sin t J_0(\rho t) dt$$

From the known value of this integral¹ we see that

$$s(\rho) = \frac{1}{\pi^2 \sqrt{1 - \rho^2}}$$

(b) *Copson's Method.* From equation (18) we have

$$S(\rho) = -\frac{1}{2\pi} \frac{d}{d\rho} \int_0^\rho \frac{t dt}{\sqrt{\rho^2 - t^2}} = \frac{1}{2\pi}$$

so that, from equation (19), we obtain the solution

$$\hat{s}(\rho) = -\frac{1}{\pi^2 \rho} \frac{d}{d\rho} \int_\rho^1 \frac{t dt}{\sqrt{t^2 - \rho^2}} = \frac{1}{\pi^2 \sqrt{1 - \rho^2}}$$

Mixed boundary value problems occur in the theory of elasticity in connection with "punching" and "crack" problems. For a discussion of these problems the reader is referred to I. N. Sneddon, "Fourier Transforms" (McGraw-Hill, New York, 1951), Secs. 47, 48, 52, 54, 55, where the dual integral equation approach is used, and to N. I. Muskhelishvili, "Singular Integral Equations" (Noordhoff, Groningen, 1953), Chap. 13, where an approach rather similar to Copson's method is used.

PROBLEMS

1. If n is zero or a positive integer and if both a and b are positive, prove that

$$\int_0^{2\pi} \frac{e^{in\phi} d\phi}{\sqrt{a^2 - b^2 - 2ab \cos \phi}} = \frac{4}{(ab)^n} \int_0^{\min(a,b)} \frac{t^{2n} dt}{\sqrt{(a^2 - t^2)(b^2 - t^2)}}$$

where both square roots are taken to be positive.

¹ Watson, "A Treatise on the Theory of Bessel Functions," p. 405.

2. If $f(x)$ and $f'(x)$ are continuous in the closed interval $[0, a]$, show that the solution¹ of the integral equation

$$f(x) = \int_0^x \frac{g(t) dt}{\sqrt{x^2 - t^2}} \quad 0 < x < a$$

is

$$g(x) = \frac{2}{\pi} \frac{d}{dx} \int_0^x \frac{tf(t) dt}{\sqrt{x^2 - t^2}}$$

3. If $f(x)$ and $f'(x)$ are continuous in $c < x < a$, prove that the solution¹ of the integral equation

$$f(x) = \int_x^a \frac{g(t) dt}{\sqrt{t^2 - x^2}} \quad c < x < a$$

is

$$g(x) = -\frac{2}{\pi} \frac{d}{dx} \int_x^a \frac{tf(t) dt}{\sqrt{t^2 - x^2}}$$

4. A disk of unit radius is grounded in a uniform external field of strength E parallel to its surface. Prove that the surface density of electric charge is given by the equation

$$\sigma(\rho) = \frac{2E\rho \cos \phi}{\pi^2 \sqrt{1 - \rho^2}}$$

5. Show that in Gallop's case $n = 0$, $G(\rho) = J_0(c\rho)$ the problem of the electrified disk has a solution of the form

$$\sigma(\rho) = \frac{c}{2\pi} J_0(c\rho) + \frac{1}{\pi^2} \int_1^\infty \frac{t \cos(ct)}{(t^2 - \rho^2)^{3/2}} dt$$

11. The Two-dimensional Laplace Equation

In some problems of potential theory the physical conditions are identical in all planes parallel to a given plane, say the plane $z = 0$. In that case the potential function ψ does not depend on z , so that $\partial\psi/\partial z$ and $\partial^2\psi/\partial z^2$ vanish identically, and Laplace's equation reduces to the form

$$\frac{\partial^2\psi}{\partial x^2} + \frac{\partial^2\psi}{\partial y^2} = 0 \quad (1)$$

If we introduce the operator

$$\nabla_1^2 = \frac{\partial^2}{\partial x^2} + \frac{\partial^2}{\partial y^2} \quad (2)$$

¹ In the solution of Probs. 2 and 3 use is made of the fact that the solution of Abel's integral equation

$$f(x) = \int_a^x \frac{u(\xi) d\xi}{(x - \xi)^\lambda} \quad 0 < \lambda < 1$$

is

$$u(x) = \frac{\sin(\pi\lambda)}{\pi} \frac{d}{dx} \int_a^x \frac{f(t) dt}{(x - t)^{1-\lambda}}$$

Cf. Bocher, *op. cit.*, p. 8.

we may write this equation simply as

$$\nabla_1^2 \psi = 0 \quad (3)$$

We shall refer to equation (3) as the *two-dimensional Laplace equation*.

The theory of the two-dimensional Laplace equation is of particular interest because of its connection with the theory of functions of a complex variable. We shall give a brief account of this relationship in the next section. In the remainder of this section we shall indicate how methods similar to those employed in the case of the three-dimensional equation yield information about the solutions of equation (3).

It is a well-known result of elementary calculus¹ that if $P(x, y)$ and $Q(x, y)$ are functions defined inside and on the boundary C of the closed area K , then

$$\int_K \left(\frac{\partial Q}{\partial x} - \frac{\partial P}{\partial y} \right) dS = \int_C (P dx + Q dy) \quad (4)$$

If, in this result, we substitute

$$P = -\frac{\partial \psi}{\partial y}, \quad Q = \frac{\partial \psi}{\partial x}$$

and make use of the fact that

$$\frac{\partial \psi}{\partial x} dy - \frac{\partial \psi}{\partial y} dx = \frac{\partial \psi}{\partial n} ds$$

where $\partial \psi / \partial n$ denotes the derivative of ψ in the direction of the outward normal to C , we find that

$$\int_K (\nabla_1^2 \psi) dS = \int_C \frac{\partial \psi}{\partial n} ds \quad (5)$$

Hence if the function $\psi(x, y)$ is harmonic within a region K and is continuous with its first derivatives on the boundary C , then

$$\int_C \frac{\partial \psi}{\partial n} ds = 0 \quad (6)$$

This result is sometimes known as the *theorem of the vanishing flux*.

It is immediately obvious from equation (5) that the converse of this theorem is also true; i.e., if $\psi(x, y)$ is a function which is continuous together with its partial derivatives of the first and second orders throughout the interior of K and if

$$\int_{C'} \frac{\partial \psi}{\partial n} ds = 0$$

where C' is the boundary of any arbitrary region K' contained in K , then ψ is harmonic in K .

¹ R. P. Gillespie, "Integration" (Oliver & Boyd, Edinburgh, 1939), p. 54.

Similarly it follows from equation (5) that if $\nabla_1^2 \psi = -4\pi\rho$ throughout K , then

$$\int_C \frac{\partial \psi}{\partial n} ds = -4\pi \int_K \rho(x, y) dS \quad (7)$$

Laplace's equation in two dimensions when written in plane polar coordinates r, θ assumes the form

$$\nabla_1^2 \psi = \frac{1}{r} \frac{\partial}{\partial r} \left(r \frac{\partial \psi}{\partial r} \right) + \frac{1}{r^2} \frac{\partial^2 \psi}{\partial \theta^2} = 0$$

so that if ψ is a function of r alone,

$$\frac{d}{dr} \left(r \frac{d\psi}{dr} \right) = 0$$

from which it readily follows that

$$\psi = A \log r + B$$

where A and B are constants. If we write

$$\psi = 2q \log \frac{1}{r} \quad (8)$$

with q a constant, then $\nabla_1^2 \psi = 0$ except possibly at the origin, where ψ is not defined. This solution has the property that if C is any circle with center at the origin, the flux of ψ through that circle is $-4\pi q$. It therefore corresponds to a uniform line density q along the z axis which appears as a point singularity in the two-dimensional theory.

In a manner similar to that employed in the three-dimensional case (Sec. 2) we could construct potential functions of the type

$$\psi(r) = \int_C q(\mathbf{r}') \log \frac{1}{|\mathbf{r} - \mathbf{r}'|} ds' \quad (9)$$

where $\mathbf{r} = (x, y)$, etc. Because of this form of ψ a two-dimensional potential function is referred to as a logarithmic potential. It is readily shown that if C has a continuously turning tangent and if $q(x', y')$ is bounded and integrable, $\psi(x, y)$, defined by (9), is continuous for all finite points of the plane including passage through the curve C . If $q(x', y')$ is continuous on C , which itself has continuous curvature, then, in the notation of Fig. 28,

$$\left[\frac{\partial \psi_2}{\partial n} - \frac{\partial \psi_1}{\partial n} \right]_A = -2\pi q(A) \quad (10)$$

$$\left[\frac{\partial \psi_2}{\partial n} + \frac{\partial \psi_1}{\partial n} \right]_A = 2 \int_C q(\mathbf{r}') \left[\frac{\partial}{\partial n} \log \frac{1}{|\mathbf{r} - \mathbf{r}'|} \right]_A ds' \quad (11)$$

Similarly the potential of a doublet distribution on a line C is given by an expression of the form

$$\begin{aligned} \psi &= \int_C \mu(\mathbf{r}') \frac{\partial}{\partial n} \log \frac{1}{|\mathbf{r} - \mathbf{r}'|} ds' \\ &= \int_C \mu \frac{\cos(\mathbf{n}, \boldsymbol{\rho})}{\rho} ds' \quad \boldsymbol{\rho} = \mathbf{r} - \mathbf{r}' \end{aligned}$$

If the tangent to the curve C turns continuously and if μ is continuous on C , then

$$\psi_2 - \psi_1 = 2\pi\mu(A), \quad \psi_2 - \psi_1 = 2\psi(A) \tag{12}$$

We shall now make use of these results to show how the interior Dirichlet problem

$$\nabla^2 \psi = 0 \text{ within } V, \quad \psi = f \text{ on } C \tag{13}$$

may be reduced to a problem in the theory of integral equations. If we assume that

$$\psi(x, y) = \int_C \mu(s') \frac{\cos(\mathbf{n}, \boldsymbol{\rho})}{\rho} ds'$$

where the function μ is unknown, then it follows from equations (12) that

$$\psi_1 = \psi(A) - \pi\mu(A)$$

so that from equation (13)

$$f(s) = \int_C \mu(s') \left[\frac{\cos(\mathbf{n}, \boldsymbol{\rho})}{\rho} \right]_A ds' - \pi\mu(s)$$

If we write

$$\frac{f(s)}{\pi} = g(s), \quad \frac{1}{\pi} \left[\frac{\cos(\mathbf{n}, \boldsymbol{\rho})}{\rho} \right]_A = K(s, s')$$

then the problem reduces to that of solving the nonhomogeneous integral equation of the second kind

$$\mu(s) + g(s) = \int_C \mu(s') K(s, s') ds'$$

for the unknown function μ .

For a full discussion of the applications of the theory of integral equations to Dirichlet's problem the reader is referred to Chap. 7 of Muskhelishvili's "Singular Integral Equations" cited above.

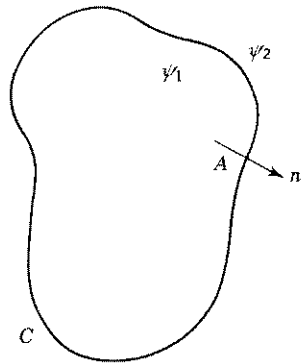

Figure 28

PROBLEMS

1. Prove that if ψ is continuous within and on the circumference of a circle and is harmonic in the interior, then the value of ψ at the center is equal to the mean value on the boundary.

2. Prove that if ψ is harmonic inside a region S and is continuous on the boundary C , then ψ takes on its largest and its smallest value on C . Furthermore that if ψ is not a constant, then it cannot have an absolute maximum or minimum inside S .
3. Show that if a_n and b_n are constants,

$$\psi(r, \theta) = \frac{1}{2}a_0 + \sum_{n=1}^{\infty} \left(\frac{r}{a}\right)^n (a_n \cos n\theta + b_n \sin n\theta)$$

is a solution of $\nabla_1^2 \psi = 0$ in the interior of the sphere $r = a$.

If $\psi = f(\theta)$ when $r = a$, determine the constants and show that

$$\psi(r, \theta) = \frac{a^2 - r^2}{2\pi} \int_0^{2\pi} \frac{f(\theta') d\theta'}{a^2 - 2ar \cos(\theta' - \theta) + r^2}$$

4. If $\nabla_1^2 \psi = 0$ for $x \geq 0$ and $\psi = f(y)$ on $x = 0$, show by using the method of Fourier transforms that

$$\psi(x, y) = \frac{1}{\sqrt{2\pi}} \int_{-\infty}^{\infty} F(\xi) e^{-|\xi|x - i\xi y} d\xi$$

where $F(\xi)$ is the Fourier transform of $f(y)$.

Deduce that

$$\psi(x, y) = \frac{x}{\pi} \int_{-x}^{\infty} \frac{f(y') dy'}{x^2 - (y - y')^2}$$

5. Reduce the solution of the exterior Dirichlet problem to that of an integral equation.
6. By taking

$$\psi(\mathbf{r}) = \int_C g(s') \log \frac{1}{|\mathbf{r} - \mathbf{r}'|} ds'$$

show that the solution of the interior Neumann problem

$$\nabla^2 \psi = 0 \text{ inside } S, \quad \frac{\partial \psi}{\partial n} = f \text{ on } C$$

reduces to that of the integral equation

$$g(s) + \int_C K(s', s) g(s') ds' = g(s)$$

$$\text{where } g(s) = \frac{f(s)}{\pi}, \quad K(s', s) = \frac{1}{\pi} \left[\frac{\partial}{\partial n} \log \frac{1}{|\mathbf{r} - \mathbf{r}'|} \right]_A$$

12. Relation of the Logarithmic Potential to the Theory of Functions

There is a close connection between the theory of two-dimensional harmonic functions and the theory of analytic functions of a complex variable. The class of analytic functions of a complex variable $z = x + iy$ consists of the complex functions of z which possess a

derivative at each point. It can be shown¹ that if ϕ and ψ are the real and imaginary parts of an analytic function of the complex variable $x + iy$, then ϕ and ψ must satisfy the Cauchy-Riemann equations

$$\frac{\partial\phi}{\partial x} = \frac{\partial\psi}{\partial y}, \quad \frac{\partial\phi}{\partial y} = -\frac{\partial\psi}{\partial x} \quad (1)$$

Now it can be proved that the derivative of an analytic function is itself analytic, so that the functions ϕ and ψ will have continuous partial derivatives of all orders and, in particular, Schwartz's theorem

$$\frac{\partial^2\phi}{\partial x \partial y} = \frac{\partial^2\phi}{\partial y \partial x}, \quad \frac{\partial^2\psi}{\partial x \partial y} = \frac{\partial^2\psi}{\partial y \partial x} \quad (2)$$

will hold. Combining the results (1) and (2), we then find that

$$\nabla_1^2\phi = \nabla_1^2\psi = 0 \quad (3)$$

i.e., the real and imaginary parts of an analytic function are harmonic functions. The functions ϕ , ψ so defined are called *conjugate functions*.

The converse result is also true: *If the harmonic functions ϕ and ψ satisfy the Cauchy-Riemann equations, then $\phi + i\psi$ is an analytic function of $z = x + iy$.*

If either $\phi(x, y)$ or $\psi(x, y)$ is given, it is possible to determine the analytic function $w = \phi + i\psi$, for, by equations (1),

$$\frac{dw}{dz} = \frac{\partial\phi}{\partial x} + i\frac{\partial\psi}{\partial x} = \phi_1(x, y) + i\phi_2(x, y)$$

where $\phi_1 = \partial\phi/\partial x$, $\phi_2 = \partial\phi/\partial y$. Putting $y = 0$, we have the identity

$$\frac{dw}{dz} = \phi_1(z, 0) + i\phi_2(z, 0) \quad (4)$$

from which w may be derived by a simple integration. If ψ is given, then, in a similar notation,

$$\frac{dw}{dz} = \psi_2(z, 0) + i\psi_1(z, 0) \quad (5)$$

Example 9. Prove that the function

$$\phi = x - \frac{x}{x^2 + y^2}$$

is a harmonic function, and find the corresponding analytic function $\phi + i\psi$.

For this function

$$\frac{\partial\phi}{\partial x} = 1 - \frac{x^2 - y^2}{(x^2 + y^2)^2}, \quad \frac{\partial\phi}{\partial y} = -\frac{2xy}{(x^2 + y^2)^2}$$

and a further pair of differentiations shows that $\nabla_1^2\phi = 0$. Putting $y = 0$, $x = z$ in

¹ See, for instance, L. V. Ahlfors, "Complex Analysis" (McGraw-Hill, New York, 1953), pp. 38-40.

these equations, we find that $\phi_1(z,0) = 1 - z^{-2}$, $\phi_2(z,0) = 0$, so that

$$\frac{dw}{dz} = 1 - \frac{1}{z^2}$$

from which it follows that

$$w = z + \frac{1}{z}$$

The conjugate function ψ is therefore given by the equation

$$\psi = y - \frac{y}{x^2 + y^2}$$

In the notation of vector analysis the Cauchy-Riemann equations (1) can be written in the form

$$\text{grad } \phi = (\text{grad } \psi) \times \mathbf{k} \quad (6)$$

where $\mathbf{k} = (0,0,1)$ is the unit vector in the z direction, from which we conclude that the sets of curves $\phi = \text{constant}$ and $\psi = \text{constant}$ intersect orthogonally. Also if \mathbf{s} is a unit vector in any direction and \mathbf{n} is a unit vector perpendicular to \mathbf{s} measured anticlockwise from \mathbf{s} (cf. Fig. 29), we get the general results

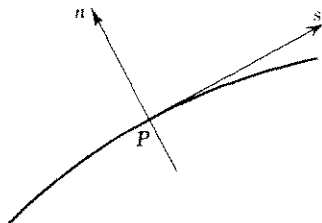

Figure 29

$$\frac{\partial \phi}{\partial s} = \frac{\partial \psi}{\partial n}, \quad \frac{\partial \phi}{\partial n} = -\frac{\partial \psi}{\partial s} \quad (7)$$

We consider now the application of these results to the motion of an incompressible fluid in two dimensions. If (u,v) denote the components of velocity at a point (x,y) in the fluid, then if the fluid is incompressible,

$$\frac{\partial u}{\partial x} + \frac{\partial v}{\partial y} = 0 \quad (8)$$

and

$$\frac{\partial v}{\partial x} - \frac{\partial u}{\partial y} = \zeta \quad (9)$$

where ζ denotes the vorticity. If, therefore, a fluid is incompressible, it follows from equation (8) that there exists a function ψ such that

$$u = -\frac{\partial \psi}{\partial y}, \quad v = \frac{\partial \psi}{\partial x} \quad (10)$$

and, from equation (9),

$$\zeta = \nabla_1^2 \psi \quad (11)$$

If, in addition, the motion is irrotational, then

$$\nabla_1^2 \psi = 0 \quad (12)$$

On the other hand if the fluid is incompressible,

$$\frac{\partial v}{\partial x} - \frac{\partial u}{\partial y} = 0$$

so that there exists a function ϕ such that

$$u = -\frac{\partial \phi}{\partial x}, \quad v = -\frac{\partial \phi}{\partial y} \quad (13)$$

and

$$\frac{\partial u}{\partial x} + \frac{\partial v}{\partial y} = -\nabla_1^2 \phi$$

If, in addition, the fluid is incompressible, then

$$\nabla_1^2 \phi = 0 \quad (14)$$

Hence for the irrotational motion of an incompressible fluid both ψ and ϕ exist and satisfy Laplace's equation. The function ψ is called the *stream function* and ϕ the *velocity potential*. From the equations (10) and (11) we have immediately that

$$\frac{\partial \phi}{\partial x} = \frac{\partial \psi}{\partial y}, \quad \frac{\partial \phi}{\partial y} = -\frac{\partial \psi}{\partial x}$$

so that the Cauchy-Riemann conditions are satisfied and

$$w = \phi + i\psi \quad (15)$$

is an analytic function of the complex variable $z = x + iy$. The function w is called the *complex potential* of the motion. Since

$$\frac{dw}{dz} = \frac{\partial \phi}{\partial x} + i \frac{\partial \psi}{\partial x}$$

it follows that

$$\frac{dw}{dz} = -u + iv \quad (16)$$

showing that

$$\left| \frac{dw}{dz} \right| = \sqrt{u^2 + v^2} = q \quad (17)$$

is the magnitude of the resultant velocity at a point in the fluid.

The stream function ψ is constant along a streamline.

If the motion is steady, the pressure p at a point in the fluid may be derived from Bernoulli's theorem which states that along a streamline

$$\frac{p}{\rho} + \frac{1}{2}q^2 + V$$

is a constant whose value depends on the particular streamline chosen; V denotes the potential energy in the field.

It is sometimes convenient to use relations of the kind

$$z = f(w)$$

instead of $w = f(z)$. It is readily shown that

$$\frac{1}{q} = \left| \frac{dz}{dw} \right| \quad (18)$$

Example 10. Show that the relation

$$w = U \left(z + \frac{a^2}{z} \right)$$

gives the motion of a fluid round a cylinder of radius a with its origin fixed at the origin in a stream whose velocity in the direction Ox is U .

Separating the complex function

$$\phi + i\psi = -U \left(x + iy + \frac{a^2(x - iy)}{x^2 + y^2} \right)$$

into its real and imaginary parts we find that

$$\phi = -Ux \left(1 + \frac{a^2}{x^2 + y^2} \right), \quad \psi = -Uy \left(1 - \frac{a^2}{x^2 + y^2} \right)$$

The components of velocity are therefore given by the equations

$$u = U \left(1 - \frac{a^2(y^2 - x^2)}{(x^2 + y^2)^2} \right), \quad v = -2U \frac{a^2xy}{(x^2 + y^2)^2}$$

It follows therefore that $\psi = 0$ on the circle with equation $x^2 + y^2 = a^2$ and that at a great distance from the origin $u = U$, $v = 0$. The given complex potential therefore satisfies the stated conditions.

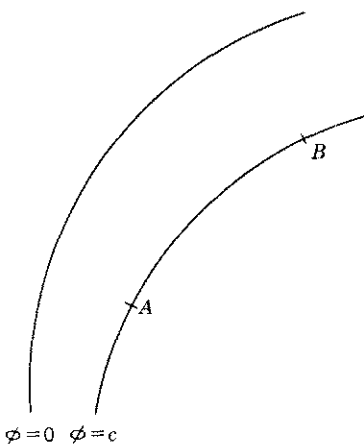

Figure 30

Two-dimensional problems in electrostatics can be tackled in a similar way. In this case ϕ denotes the electrostatic potential, so that the lines in the xy plane with equations $\phi = \text{constants}$ are the equipotential surfaces. The lines $\psi = \text{constant}$ cut these lines orthogonally, and so they must correspond to the lines of force. A potential function ϕ derived in this way could solve the problem of the distribution of electric force in a condenser formed by two conductors, one of which has equation $\phi = 0$, and the other of which has equation $\phi = c$. The charge

distribution in such a problem can be calculated easily. If σ is the charge density at a point, then

$$\sigma = -\frac{1}{4\pi} \frac{\partial \phi}{\partial n} = \frac{1}{4\pi} \frac{\partial \psi}{\partial s}$$

by the second of equations (7). Hence the total charge between A and B per unit length perpendicular to the xy plane is

$$q = \int_A^B \sigma ds = \frac{1}{4\pi} (\psi_B - \psi_A) \quad (19)$$

a result which is of great use in the calculation of capacities.

For instance, if the normal sections of two infinite conducting cylinders are given by the closed curves $\phi = c_1$ and $\phi = c_2$, where $\phi + i\psi = f(x + iy)$, then the capacity per unit length of the cylinders is

$$\frac{1}{4\pi(c_1 - c_2)} \oint d\psi \quad (20)$$

where the integral is taken round the curve $\phi = c_1$ in the positive sense.

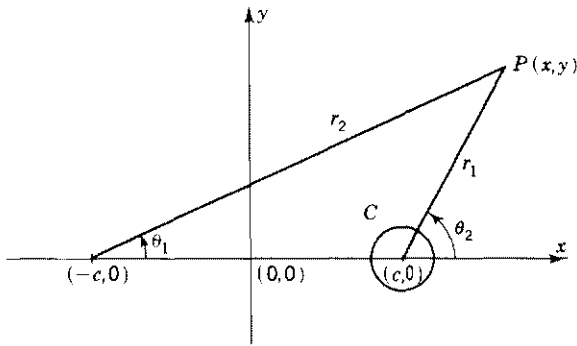

Figure 31

Example 11. An infinite conducting cylinder C of small radius a is placed parallel to an infinite plane conducting sheet and at a distance c from it. Show that the equation

$$\phi + i\psi = \log \frac{z - c}{z + c}$$

(c real) gives approximately the equipotentials and lines of force if the plate is grounded and the cylinder is at potential $-\log(2c/a)$.

Show that the capacity of this system per unit length is $[2 \log(2c/a)]^{-1}$

If

$$\phi + i\psi = \log \frac{z - c}{z + c}$$

then writing $z - c = r_1 e^{i\theta_1}$, $z + c = r_2 e^{i\theta_2}$, we see that

$$\phi = \log \frac{r_1}{r_2}, \quad \psi = i(\theta_1 - \theta_2)$$

Now on the plane $x = 0$, $r_1 = r_2$, so that $\phi = 0$ while on the cylinder if $a \ll c$, $r_2 \approx 2c$, and $r_1 = a$, so that

$$\phi = -\log \frac{2c}{a}$$

As we go round C in the positive sense, θ_1 changes by an amount 2π , while the total change in θ_2 is zero. We therefore have

$$\oint d\psi = 2\pi$$

Substituting these results in equation (20), we get the answer stated for the capacity of the system.

The main advantage of the method of conjugate functions is that the theory of conformal representation can sometimes be employed to reduce one problem to a simpler one whose solution is known. To show how this may be effected we consider the transformation

$$\zeta = f(z) \quad (21)$$

in which the function $f(z)$ is an analytic function of z , which maps the z plane on to the ζ plane.¹ Since $d\zeta = f'(z) dz$, it follows that any small element of area ΔA in the z plane in the neighborhood of the point $z = a$ becomes an element of area $|f'(a)|^2 \Delta A$ in the neighborhood of the point $\zeta = f(a)$ turned through an angle $\arg f'(a)$. It can also be shown that if two curves C_1, C_2 in the z plane intersect at an angle α , then the images Γ_1, Γ_2 of these curves in the ζ plane intersect at the same angle, the sense of rotation as well as the magnitude of α being preserved. For this reason the transformation (21) is said to be a *conformal transformation*.

The importance of conformal transformations in potential theory arises from the fact that if $\xi + i\eta = f(x + iy)$ is a conformal mapping which takes a function $\phi(x, y)$ into a function $\Phi(\xi, \eta)$, then

$$\left(\frac{\partial^2 \Phi}{\partial \xi^2} + \frac{\partial^2 \Phi}{\partial \eta^2} \right) = \left| \frac{dz}{d\zeta} \right|^2 \left(\frac{\partial^2 \phi}{\partial x^2} + \frac{\partial^2 \phi}{\partial y^2} \right) \quad (22)$$

so that if $dz/d\zeta$ is not infinite, and if

$$\frac{\partial^2 \phi}{\partial x^2} + \frac{\partial^2 \phi}{\partial y^2} = 0$$

it follows that

$$\frac{\partial^2 \Phi}{\partial \xi^2} + \frac{\partial^2 \Phi}{\partial \eta^2} = 0$$

so that the function $\Phi(\xi, \eta)$ is harmonic in the $\xi\eta$ plane. Furthermore any curve in the xy plane along which the function $\phi(x, y)$ is constant is mapped into a curve in the $\xi\eta$ plane along which the function $\Phi(\xi, \eta)$ is constant.

If there is a charge q at the point c in the z plane, then the complex potential is

$$w = -2q \log(z - c)$$

¹ *Ibid.*, pp. 69-81.

In the transformed problem the complex potential

$$\begin{aligned} W &= -2q \log \frac{dz}{d\zeta} (\zeta - \gamma) \\ &= -2q \log (\zeta - \gamma) - \Omega \end{aligned}$$

where Ω is analytic at the point $\zeta = \gamma = f(c)$. In the transformed problem there is an equal charge q at the point $\zeta = \gamma$ into which the point $z = c$ is transformed.

In any two-dimensional electrostatic problem the potential function for prescribed boundaries and distribution of charges in the z plane is equivalent to the potential function for the transformed boundaries and

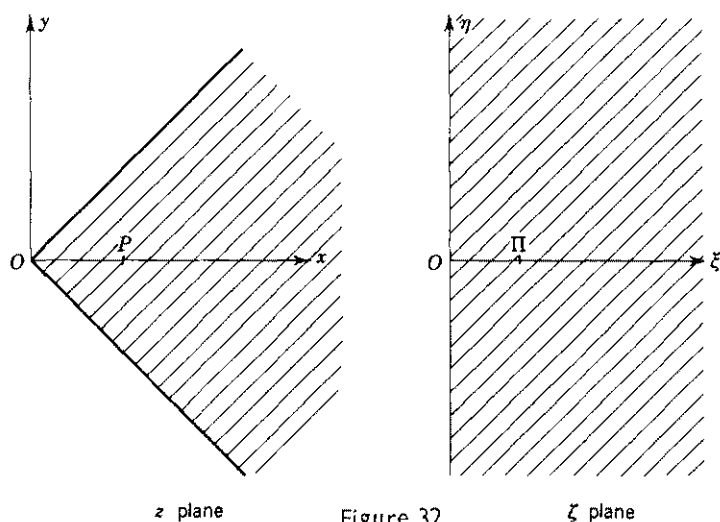

Figure 32

charges in the ζ plane. If the solution of the problem in the ζ plane is known, then by transforming back to the z plane we can derive the solution of the original problem. We shall illustrate the procedure by means of an example.

Example 12. *Midway between the grounded conducting planes $\theta = \pm\pi/(2n)$ there is placed at a distance a from the origin a point charge q . Show that the lines of force have polar equations*

$$r^{2n} - a^{2n} = 2ka^n r^n \sin(n\theta)$$

where k is a parameter.

If we make the transformation

$$\zeta = z^n = r^n e^{in\theta}$$

then the boundaries $\theta = \pm\pi/(2n)$ go into the imaginary axis $\xi = 0$ in the ζ plane, and the point $P(a,0)$ goes into the point $\Pi(a^n,0)$. Now the solution corresponding to a point charge q opposite a grounded conducting plane $\xi = 0$ is readily seen to be

$$W(\zeta) = 2q \log \frac{\zeta + a^n}{\zeta - a^n}$$

Transforming to the original variables, we therefore have the complex potential

$$w(z) = 2q \log \frac{z^n - a^n}{z^n + a^n}$$

If we write $z = re^{i\theta}$, then

$$\frac{z^n + a^n}{z^n - a^n} = \frac{r^{2n} - a^{2n} - 2ia^n r^n \sin(n\theta)}{r^{2n} - a^{2n} - 2a^n r^n \cos(n\theta)} = Re^{i\phi}$$

where

$$\tan \phi = \frac{2a^n r^n \sin(n\theta)}{r^{2n} - a^{2n}}$$

Thus $\psi = -2q\phi$, so that the lines of force $\psi = \text{constant}$ have equations of the form

$$r^{2n} - a^{2n} = 2ka^n r^n \sin(n\theta)$$

where k is a parameter.

For a complete account of the theory of conformal mappings the reader is referred to "Conformal Representation," by Z. Nehari (McGraw-Hill, New York, 1952). In the application of the theory to the solution of particular problems it will be found useful to consult H. Kober's "Dictionary of Conformal Representations" (Dover, New York, 1952).

PROBLEMS

1. Prove that the function

$$\phi = \sin x \cosh y + 2 \cos x \sinh y + x^2 - y^2 + 4xy$$

is a harmonic function, and find the corresponding analytic function $\phi - i\psi$.

2. If the two-dimensional motion of a fluid consists of outward radial flow from a point such that the rate of emission per volume per unit time is $2\pi m$, we say that the point is a simple source of strength m . Show that the complex potential of such a source at a point (a, b) is given by

$$w = -m \log(z - \gamma)$$

where $\gamma = a + ib$.

3. Show that the relation

$$w = -m \log \frac{z^2 - a^2}{z^2 + a^2}$$

gives the motion in the quadrant of a circle due to equal sources and sinks at the ends of its bounding radii.

- 4.¹ Suppose that the irrotational two-dimensional flow of incompressible inviscid fluid in the z plane is described by a complex potential $f(z)$. If there are no rigid boundaries and if the singularities of $f(z)$ are all at a distance greater than a from the origin, show that when a rigid circular cylinder $|z| = a$ is introduced into the field of flow, the complex potential becomes

$$w = f(z) - f\left(\frac{a^2}{z}\right)$$

¹ This is Milne-Thomson's circle theorem. See L. M. Milne-Thomson, *Proc. Cambridge Phil. Soc.*, 36 (1940).

5. Prove *Blasius' theorem* that if, in a steady two-dimensional irrotational motion given by the complex potential $w = f(z)$, the hydrodynamical pressures on the contour of a fixed cylinder are represented by a force (X, Y) and a couple N about the origin, then

$$X - iY = \frac{1}{2}i\rho \int_C \left(\frac{dw}{dz}\right)^2 dz$$

and

$$N = -\frac{1}{2}\rho R \int_C z \left(\frac{dw}{dz}\right)^2 dz$$

where the integrations are round any contour which surrounds the cylinder.

6. Show that the transformation

$$z = ai(kw + 1 - e^{kw})$$

determines the potential and stream functions for a conductor at potential $\phi = 0$, of which the boundary is given by the freedom equations

$$x = a(\theta - \sin \theta), \quad y = a(1 - \cos \theta)$$

Show that at points where y is large and negative the field is uniform and of strength $(ak)^{-1}$.

7. The motion of a sheet of liquid in the infinite strip of the z plane between the lines $y = 0$ and $y = a$ is due to a unit source and a unit sink at the points $(0, a/3)$ and $(0, 2a/3)$, respectively. Prove that the motion of the liquid can be determined by the transformation

$$w = \log \frac{2(\cosh \pi z/a) - 1}{2(\cosh \pi z/a) + 1}$$

and find the pressure at any point on the x axis.

13. Green's Function for the Two-dimensional Equation

The theory of the Green's function for the two-dimensional Laplace equation may be developed along lines similar to those of Sec. 8. If we put

$$P = -\psi \frac{\partial \psi'}{\partial y}, \quad Q = \psi \frac{\partial \psi'}{\partial x}$$

in equation (4) of Sec. 11, we find that

$$\int_K \psi \nabla_1^2 \psi' ds + \int_K \left(\frac{\partial \psi}{\partial x} \frac{\partial \psi'}{\partial x} + \frac{\partial \psi}{\partial y} \frac{\partial \psi'}{\partial y} \right) dS = \int_C \psi \frac{\partial \psi'}{\partial n} dS \quad (1)$$

If we interchange ψ and ψ' and subtract the two equations, we find that

$$\int_K (\psi \nabla_1^2 \psi' - \psi' \nabla_1^2 \psi) dS = \int_C \left(\psi \frac{\partial \psi'}{\partial n} - \psi' \frac{\partial \psi}{\partial n} \right) dS \quad (2)$$

Suppose that P with coordinates (x, y) is a point in the interior of the region S in which the function ψ is assumed to be harmonic. Draw a

circle Γ with center P and small radius ϵ (cf. Fig. 33), and apply the result (2) to the region K bounded by the curves C and Γ with

$$\psi' = \log \frac{1}{|\mathbf{r} - \mathbf{r}'|}$$

Since both ψ and ψ' are harmonic, it follows that if s is measured in the directions shown in Fig. 33,

$$\left(\int_{\Gamma} + \int_C \right) \left\{ \psi(x', y') \frac{\partial}{\partial n} \log \frac{1}{|\mathbf{r} - \mathbf{r}'|} - \log \frac{1}{|\mathbf{r} - \mathbf{r}'|} \frac{\partial \psi}{\partial n} \right\} ds' = 0 \quad (3)$$

Proceeding as in the three-dimensional case, we can show that

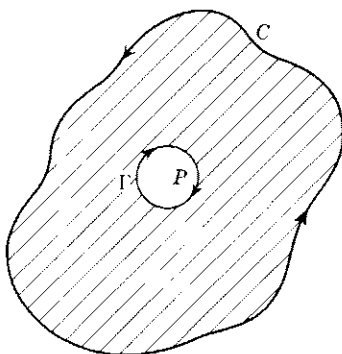

Figure 33

$$\int_{\Gamma} \psi \frac{\partial}{\partial n} \log \frac{1}{|\mathbf{r} - \mathbf{r}'|} ds' = 2\pi\psi(x, y) + O(\epsilon)$$

and that

$$\left| \int_{\Gamma} \log \frac{1}{|\mathbf{r} - \mathbf{r}'|} \frac{\partial \psi}{\partial n} ds' \right| \leq -2\pi M \epsilon \log \epsilon$$

where M is an upper bound of $\partial\psi/\partial r$.

Inserting these results into equation (3), we find that

$$\psi(x, y) = \frac{1}{2\pi} \int_C \left\{ \log \frac{1}{|\mathbf{r} - \mathbf{r}'|} \frac{\partial \psi(x', y')}{\partial n} - \psi(x', y') \frac{\partial}{\partial n} \log \frac{1}{|\mathbf{r} - \mathbf{r}'|} \right\} ds' \quad (4)$$

analogous to equation (3) of Sec. 8.

If we now introduce a Green's function $G(x, y; x', y')$, defined by the equations

$$G(x, y; x', y') = w(x, y; x', y') + \log \frac{1}{|\mathbf{r} - \mathbf{r}'|} \quad (5)$$

where the function $w(x, y; x', y')$ satisfies the relations

$$\left(\frac{\partial^2}{\partial x'^2} + \frac{\partial^2}{\partial y'^2} \right) w(x, y; x', y') = 0 \quad (6)$$

$$w(x, y; x', y') = \log |\mathbf{r} - \mathbf{r}'| \text{ on } C \quad (7)$$

then just as in the three-dimensional case the solution of the Dirichlet problem

$$\nabla_1^2 \psi = 0 \text{ within } S, \quad \psi = f(x, y) \text{ on } C \quad (8)$$

is given by the expression

$$\psi(x, y) = -\frac{1}{2\pi} \int_C \psi(x', y') \frac{\partial G(x, y; x', y')}{\partial n} ds' \quad (9)$$

where \mathbf{n} is the outward-drawn normal to the boundary curve C .

We consider two special cases:

(a) *Dirichlet's Problem for a Half Plane.* Suppose that we wish to solve the boundary value problem $\nabla_1^2 \psi = 0$ for $x \geq 0$, $\psi = f(y)$ on $x = 0$, and $\psi \rightarrow 0$ as $x \rightarrow \infty$. If P is the point (x, y) ($x > 0$), Π is $(-x, y)$, and Q is (x', y') , then

$$G(x, y; x', y') = \log \frac{Q\Pi}{QP}$$

(cf. Fig. 25) satisfies both equation (6) and equation (7), since $\Pi Q = PQ$ on $x = 0$. The required Green's function is therefore

$$G(x, y; x', y') = \frac{1}{2} \log \frac{(x + x')^2 + (y - y')^2}{(x - x')^2 + (y - y')^2} \quad (10)$$

Now on C

$$\frac{\partial G}{\partial n} = - \left(\frac{\partial G}{\partial x'} \right)_{x'=0} = - \frac{2x}{x^2 + (y - y')^2}$$

so that substituting in equation (9), we find that

$$\psi(x, y) = \frac{\pi}{x} \int_{-\infty}^{\infty} \frac{f(y') dy'}{x^2 + (y - y')^2} \quad (11)$$

This is in agreement with what we found in Prob. 3 of Sec. 8 and Prob. 4 of Sec. 11.

(b) *Dirichlet's Problem for a Circle.* In this instance we wish to find a solution of the boundary value problem

$$\nabla_1^2 \psi = 0, \quad r < a, \quad \psi = f(\theta) \text{ on } r = a$$

We take P to be the point (r, θ) , Q to be (r', θ') , and Π to be the inverse point to P and therefore to have coordinates $(a^2/r, \theta)$ (cf. Fig. 26). We see that

$$G(r, \theta; r', \theta') = \log \frac{r \cdot \Pi Q}{a \cdot PQ}$$

is harmonic within the circle except at the point Q , where it has the right kind of singularity. Further, G vanishes on the circle $r = a$. We therefore have

$$G(r, \theta; r', \theta') = \frac{1}{2} \log \frac{a^2 + r^2 r'^2 / a^2 - 2rr' \cos(\theta' - \theta)}{r'^2 + r^2 - 2rr' \cos(\theta' - \theta)}$$

Now on C

$$\frac{\partial G}{\partial n} = \left(\frac{\partial G}{\partial r'} \right)_{r'=a} = \frac{-(a^2 - r^2)}{a(a^2 - 2ar \cos(\theta' - \theta) + r^2)}$$

so that

$$\psi(r, \theta) = \frac{a^2 - r^2}{2\pi} \int_0^{2\pi} \frac{f(\theta') d\theta'}{a^2 - 2ar \cos(\theta' - \theta) + r^2} \quad (12)$$

in agreement with what we found previously in Prob. 3 of Sec. 11.

Equation (12) is known as Poisson's integral solution of the two-dimensional problem.

We shall conclude this section with a theorem about the two-dimensional Dirichlet problem which has no counterpart in three-dimensional space. It concerns the relation between conformal mapping and Green's function. Suppose that the function

$$w = f(z)$$

maps the region S in the xy plane on the unit circle in the uv plane in such a way that $f(a) = 0$. Then the function f must be of the form

$$f(z) = (z - a)e^{g(z)}$$

where g is regular and $f(z) = 1$ on C . Hence

$$\log f(z) = \log(z - a) + g(z)$$

vanishes on C , is harmonic in S , and has a singularity like $\log r$, so that

$$\log |f(z)| = -G(x, y; u, v)$$

On the other hand, $\log |f(z)|$ is determined by $G(x, y; u, v)$, and therefore so is $\operatorname{Rg} g(z)$, and hence $g(z)$ is determined within a constant. The problem of the conformal mapping of a region S in the xy plane on the unit circle in the uv plane is equivalent to that of finding the Green's function of S , i.e., to solving an arbitrary Dirichlet problem for the region S .

PROBLEMS

1. Use Poisson's integral formula to show that if the function ψ is harmonic in a circle S and continuous on the closure of S , the value of ψ at the center of S is equal to the arithmetic mean of its value on the circumference of S .
2. If the function $\psi(x, y)$ is harmonic within a circle of radius a with center the origin, prove that

$$\psi(x, y) + \psi(0, 0) = R \frac{1}{\pi i a} \int_C \frac{x \, dx}{x - z}$$

where C denotes the circle $|z| = a$ in the complex x plane.

Deduce that every harmonic function $\psi(x, y)$ is analytic in x and y .

3. If the function $\psi(x, y)$ is harmonic in the interior of a region S and if A is an interior point of S at which the value of ψ is equal to the least upper bound of its values in S and on its boundary, prove that ψ is a constant.
4. Prove that if $\psi_i(x, y)$ ($i = 1, 2, \dots$) is a sequence of functions each of which is harmonic in the interior of a finite region S and continuous in S and on its boundary and if this sequence converges uniformly on the boundary of S , then it also converges uniformly in the interior of S to a limit function which is harmonic in the interior of S .†
5. Prove that if a series of nonnegative functions $\psi_i(x, y)$, harmonic in the interior of S , converges at some interior point of S , then this series converges to a harmonic function at every point of S .

† This is known as Harnack's first theorem.

Show also that the convergence is uniform in every closed bounded region of S .†

6. Prove that if a nonconstant function $\psi(x, y)$ is harmonic in the whole plane, it cannot be bounded from above or from below (*Liouville's theorem*).

MISCELLANEOUS PROBLEMS

1. Prove that if V_n is a homogeneous function of x, y, z of degree n and $r^2 = x^2 + y^2 + z^2$,

$$\nabla^2(r^m V_n) = m(m + 2n + 1)r^{m-2}V_n + r^m \nabla^2 V_n$$

Deduce Kelvin's theorem that if V_n is a harmonic function, so also is $r^{-2n-1}V_n$.

2. Prove that if V_n is a homogeneous function of x, y, z of degree n which satisfies Laplace's equation, then

$$\frac{\partial^{p+q+s} V_n}{\partial x^p \partial y^q \partial z^s}$$

is a homogeneous function of degree $n - p - q - s$ satisfying Laplace's equation.

3. Prove that if $V_n(x, y, z)$ is a homogeneous rational integral function of degree n , the function

$$\left\{ 1 - \frac{r^2}{2(2n-1)} \nabla^2 + \frac{r^4}{2 \cdot 4(2n-1)(2n-3)} \nabla^4 - \dots \right\} V_n(x, y, z)$$

where
$$\nabla^{2s} = \frac{\partial^{2s}}{\partial x^{2s}} + \frac{\partial^{2s}}{\partial y^{2s}} + \frac{\partial^{2s}}{\partial z^{2s}}$$

is a harmonic function.

4. A number of point charges e_k are placed in positions having rectangular coordinates (ξ_k, η_k, ζ_k) . Show that inside any sphere around O in which there are no charges the electrostatic potential is given by

$$\phi(x, y, z) = \sum_{n=0}^{\infty} r^n S_n$$

where

$$S_n = \sum_k \frac{e_k}{\rho_k^{n+1}} P_n(\mu_k)$$

$$r = (x^2 + y^2 + z^2)^{\frac{1}{2}}, \quad \rho_k = (\xi_k^2 + \eta_k^2 + \zeta_k^2)^{\frac{1}{2}}, \quad \mu_k = \frac{\xi_k x + \eta_k y + \zeta_k z}{\rho_k r}$$

Show that if ϕ is a symmetrical function of x^2, y^2 , and z^2 , then $S_n = 0$ for $n = 1, 2$, and 3 .

Find expressions for the potential near O , correct to terms in r^4 , for: (a) six equal charges e at the six points $(\pm a, 0, 0)$; $(0, \pm a, 0)$; $(0, 0, \pm a)$; (b) eight equal charges $-e$ at the eight points $(\pm b, \pm b, \pm b)$.

Show that to the order considered the electric intensities are the same if $8a^5 = 81\sqrt{3}b^5$. [$P_2 = \frac{1}{2}(3\mu^2 - 1)$ and $P_4 = \frac{1}{8}(35\mu^4 - 30\mu^2 + 3)$ may be assumed.]

5. A mass m is at a point whose displacement from the origin is \mathbf{a} . Show that its potential at a sufficiently great distance r from the origin is

$$\left\{ 1 - (\mathbf{a} \cdot \nabla) + \frac{1}{2!} (\mathbf{a} \cdot \nabla)^2 - \frac{1}{3!} (\mathbf{a} \cdot \nabla)^3 + \dots \right\} \frac{\gamma m}{r}$$

where ∇ is the vector operator with components $\partial/\partial x, \partial/\partial y, \partial/\partial z$.

† This is known as Harnack's second theorem.

Eight masses m are placed at the points $\pm 1, \pm 1, \pm 1$. Show that at large distances from the origin the potential is

$$V = \frac{8\gamma m}{r} - \frac{14\gamma ml^4}{r^9} \{5(x^4 + y^4 + z^4) - 3r^4\} + \text{smaller terms}$$

Deduce, or otherwise prove, that near the origin

$$V = \frac{8\gamma m}{\sqrt{3}l} - \frac{14\gamma m}{3^{3/2}l^5} \{5(x^4 + y^4 + z^4) - 3r^4\} + \text{smaller terms}$$

6. Show that the gravitational potential produced by a given distribution of matter at a distant point P is given approximately by

$$V = \frac{\gamma m}{R} + \frac{\gamma(A + B + C - 3I)}{2R^3}$$

where m is its mass, A , B , and C are its principal moments of inertia at its mass center G , I is the moment of inertia about GP , and R is the distance GP .

Relative to polar coordinates with G as pole, the surfaces of equal density are $r = a + \epsilon(a)S_2(\theta, \phi)$ where $\epsilon(a)$ is a small quantity whose square is negligible and S_2 is a surface harmonic of second order; the boundary of the matter is the surface of equal density given by $a = b$. Show that the second term in the expression for V reduces to

$$\frac{\gamma}{R^3} \int_0^b \rho(a) \frac{d}{da} (a^4 \epsilon) da \iint S_2 P_2(\cos \theta') \sin \theta d\theta d\phi$$

where θ' is the angle between r and R .

7. If the electrostatic potential of a system is given by

$$A(x^2 + y^2 + z^2)^{-3/2} z \tan^{-1} \frac{y}{x}$$

show that the lines of force lie on the surfaces

$$x^2 + y^2 + z^2 = B(x^2 + y^2)^{2/3}$$

8. The density at any point of a thin spherical shell of total mass M varies inversely as the distance of the point from a point C inside the shell at a distance c from its center O . Denoting OP by r and the angle POC by θ , prove that the potential at an external point P is

$$\frac{M}{r} \sum_{n=0}^{\infty} \left(\frac{c}{r}\right)^n \frac{P_n(\cos \theta)}{2n+1}$$

Prove that this result can be written in the form

$$\frac{M}{2\sqrt{c}} \int_0^c \frac{dx}{x^2(x^2 - 2xr \cos \theta - r^2)^{1/2}}$$

and express the potential at a point inside the shell in a similar form.

9. A small magnet is placed at the center of a spherical shell of iron of radii a and b and permeability μ . Show that the field of force outside the shell is reduced by the presence of the iron in the ratio

$$\left\{ 1 + \frac{2(\mu - 1)^2}{\mu} \left(1 - \frac{a^3}{b^3} \right) \right\}^{-1}$$

10. A nearly spherical grounded conductor has an equation

$$r = a \left[1 + \epsilon P_n(\cos \theta) \right]$$

where ϵ is small. Show that if a point charge is placed at $\theta = 0$, $r = c > a$, the total induced charge is

$$-\frac{ea}{c} \left[1 + \epsilon \left(\frac{a}{c} \right)^n \right]$$

11. A grounded nearly spherical conductor whose surface has the equation

$$r = a \left(1 + \sum_{n=2}^{\infty} \epsilon_n P_n(\cos \theta) \right)$$

is placed in a uniform electric field E which is parallel to the axis of symmetry of the conductor. Show that if the squares and products of the ϵ 's can be neglected, the potential is given by

$$Ea \left[\left(1 + \frac{2}{3} \epsilon_2 \right) \left(\frac{a}{r} \right)^2 - \frac{r}{a} \right] P_1(\cos \theta) + 3 \sum_{n=2}^{\infty} \left(\frac{n}{2n-1} \epsilon_{n-1} - \frac{n+1}{2n+3} \epsilon_{n+1} \right) \left(\frac{a}{r} \right)^{n+1} P_n(\cos \theta) \right], \quad r_1 = 0$$

12. A spherical conductor of internal radius b which is uncharged and insulated surrounds a spherical conductor of radius a , the distance between their centers being c , which is small. The charge on the inner conductor is E . Show that the surface density at a point P on the inner conductor is

$$\frac{E}{4\pi} \left(\frac{1}{a^2} - \frac{3c \cos \theta}{b^3 - a^3} \right)$$

where θ is the angle that the radius through P makes with the line of centers and terms in c^2 are neglected.

13. A point charge e is placed at a point Q distant c from the center O of two hollow concentric uninsulated spheres of radii a, b ($b > c > a$). Show that the charge induced in the inner sphere is

$$-\frac{ea}{c} \frac{b-a}{b-a}$$

If a thin plane conducting disk bounded by two concentric circles of radii a, b is placed between the spheres touching them along great circles in a plane perpendicular to OQ , show that if $a \ll c$, the charge induced on the inner sphere is approximately

$$-\frac{3ea^2}{c^2} \left(1 - \frac{c^3}{b^3} \right)$$

14. A grounded conducting sphere of radius a is placed with its center at the origin of coordinates in a field whose potential is

$$\phi = \sum_{n=1}^{\infty} A_n r^n P_n(\cos \theta)$$

Determine the charge distribution induced on the sphere, and show that the total induced charge is zero.

Prove also that there is a force acting on the sphere in the direction $\theta = 0$ of amount

$$\sum_{n=1}^{\infty} (n-1)A_n A_{n-1} a^{2n-1}$$

Deduce the force on the sphere if the initial field has intensity components

$$E_x = -E\left(1 - \frac{2x}{a}\right), \quad E_y = \frac{Ey}{a}, \quad E_z = \frac{Ez}{a}$$

at the point (x, y, z) referred to rectangular Cartesian axes, E being a constant.

15. That portion of a sphere of radius a lying between $\theta = \alpha$ and $\theta = \pi - \alpha$ is uniformly electrified with a surface density σ . Show that the potential at an external point is

$$4\pi a \sigma \left\{ \frac{a}{r} \cos \alpha + \sum_{l=1}^{\infty} \frac{1}{4l+1} [P_{2l+1}(\cos \alpha) - P_{2l+1}(\cos \pi)] \left(\frac{a}{r}\right)^{2l+1} P_{2l}(\cos \theta) \right\}$$

16. $V(r, \theta, \phi)$ is the potential of an electrostatic field in free space due to a given charge distribution. If there are no charges within $r < a$ and if the volume $r < a$ is then filled with a homogeneous dielectric of dielectric constant κ prove that the potential functions inside and outside the sphere become

$$V_0 = \frac{2}{\kappa - 1} V(r, \theta, \phi) - \frac{\kappa - 1}{(\kappa + 1)^2} \int_0^1 t^{-n} V(rt, \theta, \phi) dt \quad r < a$$

$$V_1 = V(r, \theta, \phi) - \frac{\kappa - 1}{\kappa + 1} \cdot \frac{a}{r} V(u, \theta, \phi) + \frac{\kappa - 1}{(\kappa + 1)^2} \cdot \frac{a}{r} \int_0^1 t^{-n} V(ut, \theta, \phi) dt \quad r > a$$

where $n = \kappa/(\kappa + 1)$ and $u = a^2/r$.

17. A sphere of dielectric consists of a spherical core and $n - 1$ concentric layers, the radii of the boundaries being a_1, a_2, \dots, a_n . The dielectric constants in the n regions are k_1, k_2, \dots, k_n , where each is constant throughout the corresponding region. Write down the equations which determine the potential at any point when the sphere is placed in a uniform field of electric force.

Deduce that when a sphere of radius a in which the dielectric constant $k(r)$ is a differentiable function of the distance r from the center is placed in a uniform field, the potential at any point may be expressed in the form

$$\{rA(r) + r^{-2}B(r)\} \cos \theta$$

where θ is the angle between the radius through the point and the direction of the field and $A(r), B(r)$ satisfy the differential equations

$$\frac{dA}{dr} - \frac{1}{r^3} \frac{dB}{dr} = 0, \quad \frac{d(kA)}{dr} - \frac{2}{r^3} \frac{d(kB)}{dr} = 0$$

together with certain boundary conditions which should be stated.

18. A solid sphere of radius a is composed of magnetizable material for which the permeability at the center is 4 and at the surface is unity. When the sphere is placed in a uniform field H in the direction $\theta = 0$, the scalar potential inside the sphere is of the form $(Ar + Br^2) \cos \theta$, where A and B are constants. Find the permeability at distance $r (< a)$.

Show that at a point on the diameter of symmetry the magnetic induction is of magnitude $12aH/5(a-r)$.

19. Show that the potential at external points due to a layer of attracting matter distributed over the surface of radius a with surface density S_n is

$$\frac{4\pi a^n r^2}{(2n+1)r^{n+1}} S_n$$

where S_n is a surface spherical harmonic of degree n .

Show that a distribution of matter of surface density kz^2 over the hollow sphere $r = a$ produces a potential

$$\frac{4\pi}{3} \cdot \frac{ka^4}{r} - \frac{4\pi}{15} \cdot \frac{ka^6(2z^2 - x^2 - y^2)}{r^5}$$

in the surrounding space.

20. A uniform hollow conducting sphere of radius a and conductivity σ and small thickness t has two spherical terminals of radius r and infinite conductivity with their centers at opposite ends of a diameter of the sphere. The terminals are maintained at a constant potential difference V . Show that the current which passes is

$$\frac{2\pi\sigma tV}{\log(4a^2/r^2 - 1)}$$

21. Current flows through a medium of uniform conductivity σ between two nearly concentric spheres of radii b , a ($b > a$) whose centers are a small distance ϵa apart. The potential difference between the electrodes is V_0 . Prove that the current density at the outer electrode is

$$\frac{\sigma V_0 a}{(b-a)b} \left\{ 1 + \frac{3ab^2\epsilon \cos \theta}{b^3 - a^3} \right\}$$

where θ is the angle between the line of centers and the radius vector to the point where the current density is specified.

22. A uniform infinite metal sheet of conductivity σ_1 contains a spherical inclusion of radius a and conductivity σ_2 . The current enters the medium by two small electrodes of radius δ , whose centers are on a diameter of the sphere at equal distances $b > a$ from the center of the sphere and on opposite sides of it. Show that the equivalent resistance is

$$\frac{1}{2\pi\sigma_1} \left\{ \frac{1}{\delta} - \frac{1}{b} - \frac{2}{b} \sum_{n=0}^{\infty} (2n+1) \left(\frac{a}{b}\right)^{4n+3} A_n \right\} + 0(\delta)$$

where

$$A_n = \frac{\sigma_1 - \sigma_2}{2(n+1)\sigma_1 + (2n+1)\sigma_2}$$

23. A nonconducting plane lamina bounded by two concentric circles of radii a_1 and a_2 ($a_1 > a_2$) is charged with electricity to a uniform surface density σ electrostatic units and made to rotate in its own plane with constant angular velocity ω about its center. A soft iron sphere of radius b ($b < a_1$) and permeability μ is placed with its center at the center of the lamina. Find the magnetic intensity H at the center of the sphere, and show that at a great distance from the sphere the field of the sphere is the same as that of a dipole of moment

$$\frac{2\pi\sigma\omega b^3(a_2 - a_1)(\mu - 1)}{c(\mu + 2)}$$

24. A sphere of radius a is fixed in a perfect incompressible fluid which is flowing past it in such a manner that at a great distance from the sphere the velocity is constant. A colored particle of fluid is started upstream at a point which lies on the axis of the system, and its motion is observed. If, while the particle is upstream, its distance changes from z_1 to z_2 (measured from center) in time T , show that the maximum value of the velocity of slip on the sphere is

$$\frac{3}{2T} \left[(z_1 - z_2) - \frac{a}{6} \log \frac{(z_1^3 - a^3)(z_2 - a)^3}{(z_2^3 - a^3)(z_1 - a)^3} - \frac{a}{\sqrt{3}} \tan^{-1} \frac{\sqrt{3a}(z_1 - z_2)}{2(z_1 z_2 - a^2) + a(z_1 - z_2)} \right]$$

25. A uniform solid sphere of radius a and mass M is surrounded by perfect incompressible fluid of uniform density ρ ; the fluid is enclosed by a spherical shell of radius b concentric with the solid sphere. The system is set into motion by an impulse applied to the shell, the initial velocity of which is V . Prove that the initial velocity U of the solid sphere is given by

$$\left(M + \frac{2\pi\rho a^3(2a^3 + b^3)}{3(b^3 - a^3)} \right) U = \frac{2\pi\rho a^3 b^3}{b^3 - a^3} V$$

26. A sphere of radius a moves with velocity U in a liquid of which the only boundary is an infinite rigid plane. If the liquid is at rest at a great distance from the sphere, show that its kinetic energy when the sphere is moving normal to the boundary is

$$\pi a^3 U^2 \left(\frac{1}{3} + \frac{a^3}{8d^3} \right)$$

where d is the distance of the center of the sphere from the plane and terms of order a^4/d^4 are neglected.

27. A plane annulus of matter is bounded by concentric circles of radii a and b ($b > a$) and is of constant surface density σ . Show that its gravitational potential at a point on its axis at a distance z from its center is

$$2\pi\sigma \left[(b^2 + z^2)^{1/2} - (a^2 + z^2)^{1/2} \right]$$

Obtain an expression for the potential at a point distant r ($< a$) from the center. Show that the direction of the attraction at a point in the plane of the disk distant r ($< a$) from the center is in the plane of the disk, and obtain an expression for its magnitude in the form of an infinite series.

28. The potential near the origin of a distribution of matter on a circular plate is given by the series

$$\sum_{n=0}^{\infty} A_n r^n P_n(\cos \theta)$$

Show that the surface density at a point of the plate is

$$-\frac{1}{2\pi} \left(A_1 + \frac{1 \cdot 3}{2} A_3 r^2 + \frac{1 \cdot 3 \cdot 5}{2 \cdot 4} A_5 r^4 + \dots \right)$$

29. Show that if $r = a^2 + x^2 - 2ax \cos \theta$,

$$\frac{a^2 + x^2}{\{a^2 + x^2 - 2ax \cos \theta\}^{3/2}} = 2x \frac{\partial}{\partial x} \left(\frac{1}{r} \right) = \frac{1}{r}$$

and hence expand the expression in ascending powers of $1/x$.

A line charge of density k/x^2 is set along the x axis extending from $x = f$ to $x = \infty$. A grounded conducting sphere of radius a ($f > a$) is placed with its center at the origin. Show that the surface density at any point (r, θ) on the sphere is

$$-\frac{k}{4\pi a} \sum_{r=0}^{\infty} \frac{2r}{r^{2r+1}} \frac{1}{2} \frac{a^r}{f^{r+2}} P_r(\cos \theta)$$

30. A sphere of soft iron of radius a and of uniform permeability μ is placed with its center at a point on the axis distant b from the center of a circular coil of radius c carrying a current I . If $a^2 < b^2 - c^2$, show that the field at the center of the coil is

$$2\pi I \left\{ \frac{1}{c} + (\mu - 1) \sum_{n=1}^{\infty} \frac{(n-1)A_n}{(n+n-1)(n-1)!} (-1)^{n+1} \frac{a^{2n-1}}{b^{n-1}} \right\}$$

where
$$A_n = \frac{\partial^n}{\partial b^n} \left\{ \frac{b}{b^2 - c^2} \right\}$$

31. The functions $\psi_i(\mathbf{r})$ and $\psi_e(\mathbf{r})$ are determined by the conditions:
- $\psi_e(\mathbf{r})$ is harmonic and regular outside the sphere S , $r < a$, and $\psi_e(\mathbf{r}) \sim \psi_0(\mathbf{r})$ as $r \rightarrow \infty$, where $\psi_0(\mathbf{r})$ is harmonic;
 - $\psi_i(\mathbf{r})$ is harmonic and regular inside S ;
 - $\psi_e(\mathbf{r}) = \psi_i(\mathbf{r})$, and $\mu_1(\partial\psi_e/\partial r) = \mu_2(\partial\psi_i/\partial r)$ on S , where μ_1 and μ_2 are positive constants.

Prove that

$$\psi_e(\mathbf{r}) = \psi_0(\mathbf{r}) + (1 - 2k) \frac{a}{r} \psi_0 \left(\frac{a^2 \mathbf{r}}{r^2} \right) - \frac{k(1 - 2k)a}{r} \int_0^1 \psi_0 \left(\frac{\lambda a^2 \mathbf{r}}{r^2} \right) \lambda^{-(1-k)} d\lambda$$

$$\psi_i(\mathbf{r}) = 2k\psi_0(\mathbf{r}) + k(1 - 2k) \int_0^1 \psi_0(\lambda \mathbf{r}) \lambda^{-(1-k)} d\lambda$$

where $k = \mu_2/(\mu_1 + \mu_2)$ so that $0 < k \leq 1$.

32. A magnetic sphere of radius a and permeability μ is placed at the origin in a vacuum in which the undisturbed magnetic field has potential $V_n(x, y, z)$, a homogeneous function of degree n in x , y , and z . Show that the potential of the disturbed field is given by

$$\psi = \begin{cases} \frac{2n+1}{n+n\mu-1} V_n(x, y, z) & r < a \\ \left[1 - \frac{n(\mu-1)a^{2n+1}}{(n+n\mu-1)r^{2n+1}} \right] V_n(x, y, z) & r > a \end{cases}$$

33. A magnetic dipole of moment m is situated in a vacuum at a point with position vector \mathbf{f} outside a sphere of radius a and permeability μ . Show that the magnetic potential in the interior of the sphere is

$$\frac{2}{\mu-1} \frac{\mathbf{m} \cdot (\mathbf{r} - \mathbf{f})}{|\mathbf{r} - \mathbf{f}|^3} + \frac{\mu-1}{(\mu-1)^2} \int_0^1 \frac{\mathbf{m} \cdot (\lambda \mathbf{r} - \mathbf{f})}{|\lambda \mathbf{r} - \mathbf{f}|^3} \lambda^{-\mu/(\mu+1)} d\lambda$$

and determine the potential at an external point.

34. The irrotational steady flow of a perfect fluid is symmetrical about the x axis. If $\bar{\omega} = (y^2 - z^2)\mathbf{i}$, show that the components of fluid velocity in the directions of x and $\bar{\omega}$, respectively, can be expressed in the form

$$-\frac{1}{\bar{\omega}} \frac{\partial \psi}{\partial \bar{\omega}}, \quad \frac{1}{\bar{\omega}} \frac{\partial \psi}{\partial x}$$

where the function ψ (called *Stokes' stream function*) satisfies the partial differential equation

$$\frac{\partial}{\partial x} \left(\frac{1}{\bar{\omega}} \frac{\partial \psi}{\partial x} \right) - \frac{\partial}{\partial \bar{\omega}} \left(\frac{1}{\bar{\omega}} \frac{\partial \psi}{\partial \bar{\omega}} \right) = 0$$

Show that the stream function

$$\psi = \frac{U}{2r} (r^3 - a^3) \sin^2 \theta$$

where (r, θ) are spherical polar coordinates, determines an irrotational flow outside a rigid spherical boundary $r = a$, the velocity at a large distance being uniform and of magnitude U , and that

$$\psi = \frac{3Ur^2}{4a^2} (a^2 - r^2) \sin^2 \theta$$

determines a flow inside the same boundary. Find the vorticity in the interior flow.

Show by considering the continuity of velocity and pressure at $r = a$ that the two flows can coexist in the same liquid without a rigid boundary at $r = a$.

35. Prove that the equation satisfied by the stream function in cylindrical coordinates $(x, \bar{\omega})$, with the x axis as axis of symmetry, is transformed by the conformal transformation

$$z = x + i\bar{\omega} = f(\zeta), \quad \zeta = \xi + i\eta$$

into

$$\frac{\partial}{\partial \xi} \left(\frac{1}{\bar{\omega}} \frac{\partial \psi}{\partial \xi} \right) + \frac{\partial}{\partial \eta} \left(\frac{1}{\bar{\omega}} \frac{\partial \psi}{\partial \eta} \right) = 0$$

Show that

$$\psi = - \frac{\frac{1}{2} U b^2 (\cosh \xi \pm \sinh^2 \xi \log \tanh \frac{1}{2} \xi) \sin^2 \eta}{\frac{a}{c} + \frac{b^2}{c^2} \log \frac{a \mp b - c}{a + b \mp c}}$$

where

$$x + i\bar{\omega} = c \cosh (\xi - i\eta)$$

satisfies all the conditions required of a stream function which describes the flow when a prolate spheroid of semi-axes $a = c \cosh \xi_0$, $b = \sinh \xi_0$ moves with constant velocity U in the direction of its axis of symmetry through unbounded liquid otherwise at rest.

36. If a conducting medium has the form of a circular sheet of radius b and small thickness t , and if the electrodes are coplanar circles of small radii a with their centers at the ends of a diameter, prove that the resistance between the electrodes is approximately

$$\frac{2}{\pi \sigma t} \log \frac{2b}{a}$$

37. Two sources each of strength m exist at the points $z = \pm c$ (c real), together with a sink $-2m$ at $z = 0$. Determine the complex potential of the fluid motion on the assumption that it is two-dimensional, and prove that the streamlines are the curves

$$(x^2 + y^2)^2 = c^2(x^2 - y^2 - \lambda xy)$$

where λ is a real parameter.

Show also that the fluid speed at any point P is $2mc^2/r_1 r_2 r_3$, where r_1, r_2 , and r_3 are the distances of P from the sources and the sink.

38. Four equal circular perfectly conducting electrodes of small radius are placed with their centers at the corners of a square of side a in an infinite sheet of metal of thickness t and uniform conductivity σ . One pair of opposite corners is at one potential, and the other pair at a different potential; show that the resistance between the pairs is

$$\frac{1}{2\pi\sigma t} \log_2 \frac{a}{a\sqrt{2}}$$

Show that the streamline that touches a side at the middle point leaves the electrode at an angle $\tan^{-1} \frac{1}{2}$ with the side.

39. A line source is in the presence of an infinite plane on which is fixed a semi-circular cylindrical boss of radius a , the line source being parallel to the axis of the boss. If the source is at a distance c ($> a$) from the plane and the axis of the boss, find the velocity potential of the fluid motion. Show that the radius to the point on the boss at which the pressure is a minimum makes an angle θ with the radius to the source, where

$$\tan \theta = \frac{c^2 - a^2}{c^2 + a^2}$$

40. A long circular cylinder of radius a is fixed with its axis parallel to, and at a distance c from, an infinite plane wall. The space outside the cylinder is filled with liquid, and there is a circulation κ about the cylinder. Prove that the resultant of fluid pressure on the cylinder is a force toward the wall of magnitude

$$\frac{\kappa^2 \rho}{4\pi \sqrt{c^2 - a^2}}$$

41. A cylinder whose normal section is the ellipse $x^2/a^2 + y^2/b^2 = 1$ moves in an infinite fluid at infinity. Find the appropriate ψ functions when: (a) the cylinder is rotating about its axis with a constant angular velocity ω ; (b) it is moving with a constant velocity of translation perpendicular to its axis; (c) the cylinder rotates with constant angular velocity about a line parallel to the axis and passing through the point (x_0, y_0) .

If at any moment the axis of rotation is transferred from the axis of the cylinder to the parallel line through (x_0, y_0) without altering the angular velocity, show that the increase of the kinetic energy of the fluid is

$$\frac{1}{2}\pi\rho\omega^2(a^2x_0^2 + b^2y_0^2)$$

per unit length of axis.

42. A uniform stream of incompressible perfect liquid is disturbed by an infinite strip placed broadside on to the stream; the stream is in the direction Oy , and the strip occupies the region $y = 0$, $|x| \leq a$. By using the transformation $\zeta^2 = z^2 - a^2$, or otherwise, find the w function for the disturbed motion.

Prove (a) that the velocity at a point on the axis Oy is

$$V \left(\frac{y^2}{y^2 + a^2} \right)^{\frac{1}{2}}$$

where V is the velocity of the undisturbed stream, and (b) that the equation of a streamline is

$$\frac{x^2}{\lambda^2} = 1 + \frac{y^2}{\lambda^2 + y^2}$$

where λ is a constant.

43. Show that the transformation $z = \zeta^2 - \frac{1}{4}$ maps the part of the z plane to the right of the parabola $x = -y^2$ on the part of the ζ plane to the right of the line $\xi = \frac{1}{2}$.

Hence, or otherwise, show that the complex potential

$$w = (\zeta - \frac{1}{2})^2 - \frac{1}{4} \sqrt{z + \frac{1}{4}} - \frac{1}{2}$$

is compatible with the parabola as boundary and represents a flow which is uniformly in the $-x$ direction, as $x \rightarrow -\infty$, in the presence of the parabolic obstacle.

44. Show that the transformation $w = \sin(\pi z/2a)$, where $z = x + iy$, $w = u + iv$, transforms the region S in the z plane, defined by $-a < x < a$, $y > 0$, into the upper half of the w plane. State which portions of the u axis correspond to each of the three lines bounding S .

Show also that the transformation $w = \log\{(z-1)/(z+1)\}$ transforms the upper half of the z plane into the infinite strip $0 < v < \pi$ of the w plane.

Deduce, or show otherwise, that the imaginary part of

$$\frac{V_0}{\pi} \log \left[\frac{\sin(\pi z/2a) - 1}{\sin(\pi z/2a) + 1} \right]$$

satisfies Laplace's equation in the region S and is equal to zero on the infinite boundaries and to V_0 on the finite boundary of S .

45. Show that the conformal representations $t = e^{\pi z/b}$ and $t = \cosh \pi z/b$ can be used to map an infinite strip of width b in the z plane and a semi-infinite strip of the same width in the z plane, respectively, onto the upper half of a t plane.

Find the velocity potential in a semi-infinite strip bounded by $x = 0$, $y = 0$, $y = b$ due to the existence of a source at the origin from which a volume πm of liquid flows into the region per unit time.

46. Two semi-infinite conducting plates $y = 0$, $x < 0$ and $y = a$, $x < 0$ are at potentials 0 and V_0 respectively. Show that the electrostatic field in their neighborhood is given by the complex potential function w , whose real part is the electrostatic potential V , where

$$\frac{2\pi z}{a} - 1 = \frac{2\pi iw}{V_0} = \exp \frac{2\pi iw}{V_0} \quad z = x + iy$$

Prove that the line of force passing between the extreme edges of the plates has the form of a cycloid.

47. Show that the domain outside the circle $|Z| = a$ in the Z plane is transformed into the domain outside a circular arc of equal radius in the z plane by the conformal relation

$$\frac{z}{z - ae^{2iz}} = \left(\frac{Z - ia e^{i\alpha}}{Z - ia e^{-i\alpha}} \right)^2$$

where the circular arc subtends an angle 4α at its center. Show also that z/Z tends to $\sin \alpha$ at infinity.

A cylinder whose section is the above circular arc is placed in a stream of fluid in which the velocity at a great distance from the cylinder is V . This velocity is perpendicular to the generators and makes a positive angle β with the radius from the center to the middle point of the arc. If in addition there

is a circulation k round the cylinder in the positive sense, show that the complex potential ω can be derived from

$$\omega = V \sin \gamma \left(Z e^{-i\beta} + \frac{a^2}{Z e^{-i\beta}} \right) - \frac{ik}{2\pi} \log Z$$

by eliminating Z between this equation and the above relation.

Prove that the velocity at the upper edge is finite when, and only when, $k = 2\pi a V [\sin \beta - \sin (2\alpha - \beta)]$.

48. In the conformal transformation

$$\left(\frac{\zeta - a}{\zeta + a} \right)^{\frac{1}{2}} = \left(\frac{z - c}{z + c} \right)^{\frac{1}{2}}$$

a and c are real and positive, and ζ, z are connected with r_1, r_2, θ by the relations

$$\frac{\zeta - a}{\zeta + a} = \left(\frac{r_1}{r_2} \right)^{\frac{1}{2}} e^{i\frac{1}{2}\theta}, \quad \frac{z - c}{z + c} = \frac{r_1}{r_2} e^{i\theta}$$

where r_1, r_2 are the distances of the point z from the points $-c$ and $-\pi < \theta \leq \pi$. Show that the transformation transforms the region outside the figure formed by two minor arcs ($\theta = \pm \frac{3}{4}\pi$) of orthogonal circles through the points $z = \pm c$, which are symmetrical to the line joining these points, into the region outside the circle $|\zeta| = a$.

Hence show that if a conducting cylinder whose normal section is formed by these arcs is freely charged with electricity, the density at any point of the arc is proportional to

$$r_1^{-1} r_2^{-1} (r_1^2 + r_2^2)^{-1}$$

49. Prove that the transformation

$$\frac{d\zeta}{dz} = A \prod_{r=1}^n (z - z_r)^{-\alpha_r/\pi}, \quad \sum_{r=1}^n \alpha_r = 2\pi$$

where z_r are real numbers such that $z_r < z_{r+1}$, maps conformally the interior of a polygon of n sides with exterior angles α_r , in the ζ plane ($\zeta = \xi + i\eta$) onto the upper half of the z plane. What emendations are necessary if a vertex of the polygon corresponds to the point at infinity on the real axis in the z plane?

Find the transformation which maps conformally the interior of the semi-infinite strip bounded by $\xi = 0, \eta = \alpha, \eta = -\alpha$ onto the upper half of the z plane.

50. In the plane of two-dimensional motion, liquid flows from a vessel whose sides are defined by

$$y - c + mx = 0, \quad y + c - mx = 0 \quad x \leq 0$$

where $m = \tan(\pi/2n)$. If the internal angle of the vessel is π/n , obtain an equation giving implicitly the complex potential of the liquid motion.

51. Fluid is introduced to the half space $z \leq 0$ through a circular aperture $r \leq a$ of the rigid plane $z = 0$. State the conditions to be satisfied by the velocity potential in these circumstances, and show that it may be expressed in the form

$$\frac{2\gamma}{\pi} \int_0^\infty \frac{\sin(\xi a)}{\xi} e^{-\xi z} J_0(\xi r) d\xi$$

where γ is a constant. Hence determine the components of the velocity at any point in the fluid.

52. Two axially symmetrical functions $\psi_1(\rho, z)$, $\psi_2(\rho, z)$ satisfy the conditions

- (i) $\nabla^2 \psi_1 = 0, z < 0; \quad \nabla^2 \psi_2 = 0, z > 0$
 (ii) $\psi_1 = \psi_2 \quad \text{and} \quad \frac{\partial \psi_1}{\partial z} = \frac{\partial \psi_2}{\partial z} \quad \text{for } z = 0, \rho < 1$
 (iii) $\psi_1 \rightarrow 0 \quad \text{as } \rho^2 + z^2 \rightarrow \infty$
 (iv) $\frac{\partial \psi_1}{\partial z} = 0 \quad \text{for } z = 0, \rho > 1$
 (v) $\frac{\partial \psi_2}{\partial z} \rightarrow V \quad \text{as } z \rightarrow \infty$

Show that

$$\psi_1 = \int_0^\infty \xi A(\xi) e^{\xi z} J_0(\xi \rho) d\xi, \quad \psi_2 = \kappa + Uz + \int_0^\infty \xi B(\xi) e^{-\xi z} J_0(\xi \rho) d\xi$$

where κ is a constant and

$$\begin{aligned} \int_0^\infty \xi [A(\xi) - B(\xi)] J_0(\xi \rho) d\xi &= \kappa \quad \rho < 1 \\ \int_0^\infty \xi^2 [A(\xi) + B(\xi)] J_0(\xi \rho) d\xi &= U \quad \rho < 1 \\ \int_0^\infty \xi^2 A(\xi) J_0(\xi \rho) d\xi &= 0 \quad \rho > 1 \end{aligned}$$

Verify that these conditions are satisfied by choosing

$$A(\xi) = \frac{\kappa \sin \xi}{\pi \xi^2} + \frac{U J_1(\xi)}{2 \xi^2}, \quad B(\xi) = -\frac{\kappa \sin \xi}{\pi \xi^2} + \frac{U J_1(\xi)}{2 \xi^2}$$

and that

$$\left[\frac{\partial \psi_1}{\partial z} \right]_{\rho=0} = \left[\frac{\partial \psi_2}{\partial z} \right]_{\rho=0} = \frac{1}{2} U + \frac{Uz}{2\sqrt{z^2+1}} + \frac{\kappa}{\pi(z^2+1)}$$

Chapter 5

THE WAVE EQUATION

In this chapter we shall consider the wave equation

$$\nabla^2 \psi = \frac{1}{c^2} \frac{\partial^2 \psi}{\partial t^2}$$

which is a typical hyperbolic equation. This equation is sometimes written in the form

$$\square^2 \psi = 0$$

where \square^2 denotes the operator

$$\frac{\partial^2}{\partial x^2} + \frac{\partial^2}{\partial y^2} + \frac{\partial^2}{\partial z^2} - \frac{1}{c^2} \frac{\partial^2}{\partial t^2}$$

If we assume a solution of the wave equation of the form

$$\psi = \Psi(x, y, z) e^{\pm i k c t}$$

then the function Ψ must satisfy the equation

$$(\nabla^2 + k^2) \Psi = 0$$

which is called the *space form of the wave equation* or *Helmholtz's equation*.

1. The Occurrence of the Wave Equation in Physics

We shall begin this chapter by listing several kinds of situations in physics which can be discussed by means of the theory of the wave equation.

(a) *Transverse Vibrations of a String.* If a string of uniform linear density ρ is stretched to a uniform tension T , and if, in the equilibrium position, the string coincides with the x axis, then when the string is disturbed slightly from its equilibrium position, the transverse displacement $y(x, t)$ satisfies the one-dimensional wave equation

$$\frac{\partial^2 y}{\partial x^2} = \frac{1}{c^2} \frac{\partial^2 y}{\partial t^2} \quad (1)$$

where $c^2 = T/\rho$. At any point $x = a$ of the string which is fixed $y(a, t) = 0$ for all values of t .

(b) *Longitudinal Vibrations in a Bar.* If a uniform bar of elastic material of uniform cross section whose axis coincides with Ox is stressed in such a way that each point of a typical cross section of the bar takes the same displacement $\xi(x, t)$, then

$$\frac{\partial^2 \xi}{\partial x^2} = \frac{1}{c^2} \frac{\partial^2 \xi}{\partial t^2} \quad (2)$$

where $c^2 = E/\rho$, E being the Young's modulus and ρ the density of the material of the bar. The stress at any point in the bar is

$$\sigma = E \frac{\partial \xi}{\partial x} \quad (3)$$

For instance, suppose that the velocity of the end $x = 0$ of the bar $0 \leq x \leq a$ is prescribed to be $v(t)$, say, and that the other end $x = a$ is free from stress. Suppose further that at that time $t = 0$ the bar is at rest. Then the longitudinal displacement of sections of the bar are determined by the partial differential equation (2) and the boundary and initial conditions

$$(i) \quad \frac{\partial \xi}{\partial t} = v(t) \quad \text{for } x = 0$$

$$(ii) \quad \frac{\partial \xi}{\partial x} = 0 \quad \text{for } x = a$$

$$(iii) \quad \xi = \frac{\partial \xi}{\partial t} = 0 \quad \text{at } t = 0 \text{ for } 0 \leq x \leq a$$

(c) *Longitudinal Sound Waves.* If plane waves of sound are being propagated in a horn whose cross section for the section with abscissa x is $A(x)$ in such a way that every point of that section has the same longitudinal displacement $\xi(x, t)$, then ξ satisfies the partial differential equation

$$\frac{\partial}{\partial x} \left\{ \frac{1}{A} \frac{\partial}{\partial x} (A \xi) \right\} = \frac{1}{c^2} \frac{\partial^2 \xi}{\partial t^2} \quad (4)$$

which reduces to the one-dimensional wave equation (2) in the case in which the cross section is uniform. In equation (4)

$$c^2 = \left(\frac{dp}{d\rho} \right)_0 \quad (5)$$

where the suffix 0 denotes that we take the value of $dp/d\rho$ in the equilibrium state. The change in pressure in the gas from the equilibrium value p_0 is given by the formula

$$p - p_0 = -c^2 \rho_0 \frac{\partial \xi}{\partial x} \quad (6)$$

where ρ_0 is the density of the gas in the equilibrium state. For instance, if we are considering the motion of the gas when a sound wave passes along a tube which is free at each of the ends $x = 0$, $x = a$, then we must determine solutions of equation (4) which are such that

$$\frac{\partial \xi}{\partial x} = 0 \quad \text{at } x = 0 \text{ and at } x = a$$

(d) *Electric Signals in Cables.* We have already remarked (in Sec. 2 of Chap. 3) that if the resistance per unit length R , and the leakage parameter G are both zero, the voltage $V(x,t)$ and the current $z(x,t)$ both satisfy the one-dimensional wave equation, with wave velocity c defined by the equation

$$c^2 = \frac{1}{LC} \quad (7)$$

where L is the inductance and C the capacity per unit length.

(e) *Transverse Vibrations of a Membrane.* If a thin elastic membrane of uniform areal density σ is stretched to a uniform tension T , and if, in the equilibrium position, the membrane coincides with the xy plane, then the small transverse vibrations of the membrane are governed by the wave equation

$$\nabla_1^2 z = \frac{1}{c^2} \frac{\partial^2 z}{\partial t^2} \quad (8)$$

where $z(x,y,t)$ is the transverse displacement (assumed small) at time t of the point (x,y) of the membrane. The wave velocity c is defined by the equation

$$c^2 = \frac{T}{\sigma} \quad (9)$$

If the membrane is held fixed at its boundary Γ , then we must have $z = 0$ on Γ for all values of t .

(f) *Sound Waves in Space.* Suppose that because of the passage of a sound wave the gas at the point (x,y,z) at time t has velocity $\mathbf{v} = (u,v,w)$ and that the pressure and density there and then are p , ρ , respectively; then if p_0 , ρ_0 are the corresponding values in the equilibrium state, we may write

$$\rho = \rho_0(1 + s), \quad p = p_0 + c^2 \rho_0 s \quad (10)$$

where s is called the condensation of the gas and c^2 is given by equation (5). If we substitute these expressions in the equations of motion

$$\rho \frac{D\mathbf{v}}{Dt} = -\text{grad } p \quad (11)$$

where

$$\frac{D}{Dt} = \frac{\partial}{\partial t} + u \frac{\partial}{\partial x} + v \frac{\partial}{\partial y} + w \frac{\partial}{\partial z}$$

and restrict ourselves to small oscillations of the gas, we find that

$$\rho_0 \frac{\partial \mathbf{v}}{\partial t} = -c^2 \rho_0 \text{grad } s \quad (12)$$

Similarly, the continuity equation

$$\frac{D\rho}{Dt} + \rho \text{div } \mathbf{v} = 0$$

is equivalent, in this approximation, to the equation

$$\rho_0 \frac{\partial s}{\partial t} + \rho_0 \text{div } \mathbf{v} = 0 \quad (13)$$

If the motion of the gas is irrotational, then there exists a scalar function ϕ with the property that

$$\mathbf{v} = -\text{grad } \phi \quad (14)$$

Substituting from equation (14) into equation (12), we find that for small oscillations

$$\text{grad} \left(\frac{\partial \phi}{\partial t} - c^2 s \right) = 0 \quad (15)$$

Similarly, equation (13) is equivalent to

$$\frac{\partial s}{\partial t} = \nabla^2 \phi \quad (16)$$

Eliminating s between equations (15) and (16), we find that ϕ satisfies the wave equation

$$\nabla^2 \phi = \frac{1}{c^2} \frac{\partial^2 \phi}{\partial t^2} \quad (17)$$

(g) *Electromagnetic Waves.* If we write

$$\mathbf{H} = \text{curl } \mathbf{A}, \quad \mathbf{E} = -\frac{1}{c} \frac{\partial \mathbf{A}}{\partial t} - \text{grad } \phi$$

then Maxwell's equations

$$\text{div } \mathbf{E} = 4\pi\rho, \quad \text{div } \mathbf{H} = 0$$

$$\text{curl } \mathbf{E} = -\frac{1}{c} \frac{\partial \mathbf{H}}{\partial t}, \quad \text{curl } \mathbf{H} = \frac{4\pi \mathbf{i}}{c} + \frac{1}{c} \frac{\partial \mathbf{E}}{\partial t}$$

are satisfied identically provided that \mathbf{A} and ϕ satisfy the equations

$$\nabla^2 \mathbf{A} = \frac{1}{c^2} \frac{\partial^2 \mathbf{A}}{\partial t^2} - \frac{4\pi}{c} \mathbf{i}, \quad \nabla^2 \phi = \frac{1}{c^2} \frac{\partial^2 \phi}{\partial t^2} - 4\pi\rho$$

Therefore in the absence of charges or currents ϕ and the components of \mathbf{A} satisfy the wave equation.

(h) *Elastic Waves in Solids.* If (u, v, w) denote the components of the displacement vector \mathbf{v} at the point (x, y, z) , then the components of the stress tensor are given by the equations

$$(\sigma_x, \sigma_y, \sigma_z) = \lambda \left(\frac{\partial u}{\partial x} + \frac{\partial v}{\partial y} + \frac{\partial w}{\partial z} \right) + 2\mu \left(\frac{\partial u}{\partial x}, \frac{\partial v}{\partial y}, \frac{\partial w}{\partial z} \right)$$

$$(\tau_{yz}, \tau_{zx}, \tau_{xy}) = \mu \left(\frac{\partial w}{\partial y} + \frac{\partial v}{\partial z}, \frac{\partial u}{\partial z} + \frac{\partial w}{\partial x}, \frac{\partial v}{\partial x} + \frac{\partial u}{\partial y} \right)$$

where λ and μ are Lamé's constants. The equations of motion are

$$\frac{\partial \sigma_x}{\partial x} + \frac{\partial \tau_{xy}}{\partial y} + \frac{\partial \tau_{xz}}{\partial z} + \rho X = \rho \frac{\partial^2 u}{\partial t^2}, \text{ etc.}$$

where $\mathbf{F} = (X, Y, Z)$ is the body force at (x, y, z) . If we write

$$\mathbf{F} = \text{grad } \Phi + \text{curl } \Psi$$

then it is easily shown that the displacement vector can be taken in the form

$$\mathbf{v} = \text{grad } \phi + \text{curl } \psi$$

provided that ϕ and ψ satisfy the equations

$$\frac{\partial^2 \phi}{\partial t^2} - c_1^2 \nabla^2 \phi = \Phi, \quad \frac{\partial^2 \psi}{\partial t^2} - c_2^2 \nabla^2 \psi = \Psi$$

where the wave velocities c_1, c_2 are given by

$$c_1^2 = \frac{\lambda + 2\mu}{\rho}, \quad c_2^2 = \frac{\mu}{\rho}$$

Hence, in the absence of body forces, ϕ and the components of ψ each satisfies a wave equation.

PROBLEMS

1. Prove that the total energy of a string which is fixed at the points $x = 0, x = l$ and is executing small transverse vibrations is

$$W = \frac{1}{2} T \int_0^l \left\{ \left(\frac{\partial y}{\partial x} \right)^2 + \frac{1}{c^2} \left(\frac{\partial y}{\partial t} \right)^2 \right\} dx$$

Show that if

$$y = f(x - ct) \quad 0 \leq x \leq l$$

then the energy of the wave is equally divided between potential energy and kinetic energy.

2. Show that

$$y = A(p)e^{ip(t \pm x/c)}$$

is a solution of the wave equation for arbitrary forms of the function A which depends only on p .

Interpret these solutions physically.

3. A string of length $l_1 + l_2$ is stretched to a tension ρc^2 between two points O and A . A point mass m is attached to the string at a point distant l_1 from O . Write down the conditions to be satisfied by the function describing the transverse displacement of such a string, and, making use of the result of the last problem, show that the periods of possible oscillations of the system are given by $\pi(l_1 + l_2)/c\zeta$, where ζ is any positive root of the equation

$$\cot \frac{2\zeta l_1}{l_1 + l_2} - \cot \frac{2\zeta l_2}{l_1 + l_2} = \frac{2m\zeta}{\rho(l_1 - l_2)}$$

4. A uniform stretched string of great length lies along the axis Ox from $x = -l$ to $x = +\infty$; the end at $x = -l$ is attached to a fixed point, and a particle of mass m is attached to the string at $x = 0$. A train of transverse waves in which the displacement is

$$y = a \cos \sigma \left(t + \frac{x}{c} \right)$$

travels along the string from $x = +\infty$ and is reflected. Show that stationary waves are set up in each part of the string and that in particular the displacement for $-l < x < 0$ is

$$z = 2a \frac{\cos \beta}{\sin \alpha} \sin \left(\frac{\sigma x}{c} + \alpha \right) \cos (\sigma t - \beta)$$

where $\alpha = \sigma l/c$ and

$$\tan \beta = \frac{\sigma m}{c\rho} - \cot \alpha$$

5. A uniform straight tube of length $2l$ and cross-sectional area A is closed at one end and open at the other end. A quantity of gas is imprisoned by a piston of mass M free to slide along the tube, and the piston is in equilibrium when at the middle of the tube. The density of the enclosed gas is then σ , while the density of the atmosphere is ρ . Show that the frequencies p of the oscillations of the piston about its position of equilibrium are given by

$$\frac{Mp}{A} = c\sigma \cot \frac{pl}{c} - c'\rho \tan \frac{pl}{c}$$

where c, c' are the velocities of propagation of sound in the enclosed gas and the atmosphere, respectively.

6. A particle P of mass m rests on a smooth horizontal table. It is attached to a point A by a uniform heavy string of mass Tl/c^2 and to a point B by a light inextensible string. The points A and B are on the table; in the equilibrium position $AP = l, BP = a$, and the tension of the strings is T . Prove that the normal frequencies p of the transverse vibrations of the heavy string are solutions of the equation

$$p \cot \frac{pl}{c} = -\frac{c}{a} + \frac{cm}{T} p^2$$

7. A uniform inelastic string of length l and line density ρ lies on a smooth horizontal plane. One end is attached to a fixed point A on the plane, and the other end is attached to a mass M which can slide freely along a horizontal line at a distance l from A and perpendicular to the mean position of the string. The string is subject to a tension ρc^2 . Show that if the system performs small vibrations with period $2\pi/p$, the equation to determine p is

$$\tan \frac{pl}{c} = \frac{\rho c}{\rho M}$$

Deduce that for large values of the integer n the values of p are approximately

$$\frac{c}{l} \left(n\pi - \frac{l\rho}{n\pi M} \right)$$

2. Elementary Solutions of the One-dimensional Wave Equation

We saw in Sec. 1 of Chap. 3 that a general solution of the wave equation

$$\frac{\partial^2 y}{\partial x^2} = \frac{1}{c^2} \frac{\partial^2 y}{\partial t^2} \quad (1)$$

is

$$y = f(x + ct) + g(x - ct) \quad (2)$$

where the functions f and g are arbitrary. In this section we shall show how this solution may be used to describe the motion of a string.

In the first instance we shall assume that the string is of infinite extent and that at time $t = 0$ the displacement and the velocity of the string are both prescribed so that

$$y = \eta(x), \quad \frac{\partial y}{\partial t} = v(x) \quad \text{at } t = 0 \quad (3)$$

Our problem then is to solve equation (1) subject to the initial conditions (3). Substituting from (2) into (3), we obtain the relations

$$\eta(x) = f(x) + g(x), \quad v(x) = cf'(x) - cg'(x) \quad (4)$$

Integrating the second of these relations, we have

$$f(x) - g(x) = \frac{1}{c} \int_b^x v(\xi) d\xi$$

where b is arbitrary. From this equation and the first of the equations (4) we obtain the formulas

$$f(x) = \frac{1}{2}\eta(x) + \frac{1}{2c} \int_b^x v(\xi) d\xi$$

$$g(x) = \frac{1}{2}\eta(x) - \frac{1}{2c} \int_b^x v(\xi) d\xi$$

Substituting these expressions in equation (2), we obtain the solution

$$y = \frac{1}{2} \{ \eta(x + ct) + \eta(x - ct) \} + \frac{1}{2c} \int_{x-ct}^{x+ct} v(\xi) d\xi \quad (5)$$

The solution (5) is known as *d'Alembert's solution* of the one-dimensional wave equation. If the string is released from rest, $v \equiv 0$, so that equation (5) becomes

$$y = \frac{1}{2} \{ \eta(x + ct) + \eta(x - ct) \} \quad (6)$$

showing that the subsequent displacement of the string is produced by two pulses of "shape" $y = \frac{1}{2}\eta(x)$, each moving with velocity c , one to

the right and the other to the left. Such a motion is illustrated by Fig. 34, in which the initial displacement is

$$\eta_1(x) = \begin{cases} 0 & x < -a \\ 1 & |x| \leq a \\ 0 & x > a \end{cases}$$

The motion may be represented by a series of graphs corresponding to various values of t as in this figure. Another method of representing

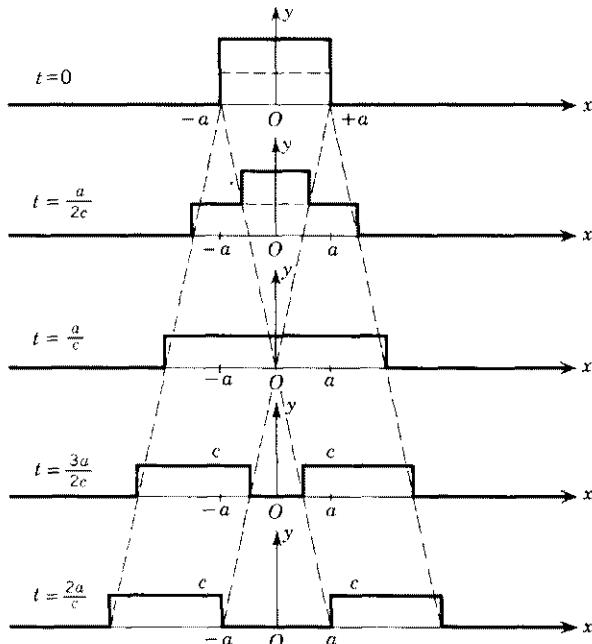

Figure 34

the motion graphically is to construct a surface from these profiles, as shown in Fig. 35.

We shall now consider the motion of a semi-infinite string $x \geq 0$ fixed at the point $x = 0$. The conditions (3) are now replaced by

$$y = \eta_1(x), \quad \frac{\partial y}{\partial t} = v(x) \quad x \geq 0 \text{ at } t = 0 \quad (7a)$$

$$y = 0, \quad \frac{\partial y}{\partial t} = 0 \quad t \geq 0 \text{ at } x = 0 \quad (7b)$$

The solution (5) is no longer applicable, since $\eta_1(x - ct)$ would not have a meaning if $t > x/c$. Suppose, however, we consider an infinite string subject to the *initial* conditions

$$y = Y(x), \quad \frac{\partial y}{\partial t} = V(x) \quad \text{at } t = 0$$

where
$$Y(x) = \begin{cases} \eta(x) & \text{if } x \geq 0 \\ -\eta(-x) & \text{if } x < 0 \end{cases}$$

and
$$V(x) = \begin{cases} v(x) & \text{if } x \geq 0 \\ -v(-x) & \text{if } x < 0 \end{cases}$$

Then its displacement is given by

$$y = \frac{1}{2} \{ Y(x + ct) - Y(x - ct) \} + \frac{1}{2c} \int_{x-ct}^{x+ct} V(\xi) d\xi \tag{8}$$

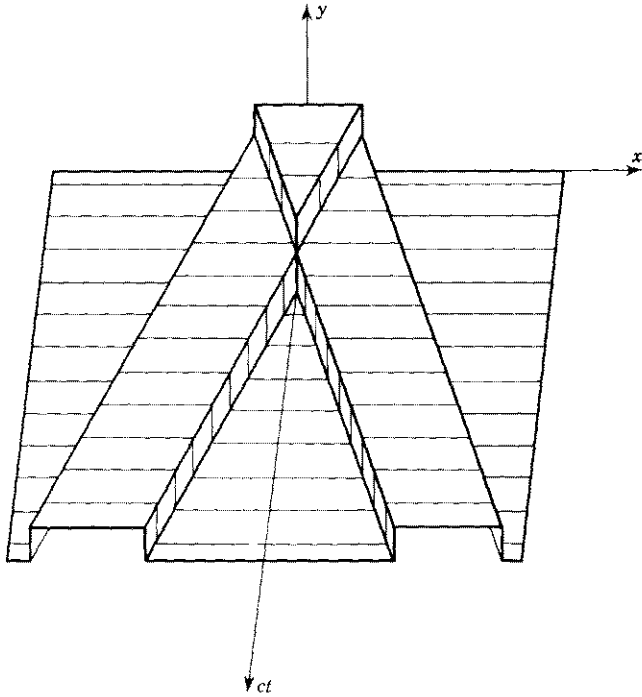

Figure 35

so that when $x = 0$

$$y = \frac{1}{2} \{ Y(ct) + Y(-ct) \} + \frac{1}{2c} \int_{-ct}^{ct} V(\xi) d\xi \tag{9}$$

and
$$\frac{\partial y}{\partial t} = \frac{1}{2} c \{ Y'(ct) - Y'(-ct) \} + \frac{1}{2} \{ V(ct) + V(-ct) \}$$

It is obvious from the definitions of Y and V that both these functions are identically zero for all values of t and that therefore the function (9) satisfies the condition (7b) as well as the differential equation (1). It is easily verified that it also satisfies the condition (7a). In particular,

if the string is released from rest so that v , and consequently V , is identically zero, we find that the appropriate solution is

$$y = \begin{cases} \frac{1}{2}[\eta(x - ct) + \eta(x + ct)] & x > ct \\ \frac{1}{2}[\eta(x - ct) - \eta(ct - x)] & x \leq ct \end{cases}$$

The graphical representation of such a solution is shown in Fig. 36. It may be obtained directly from the analytical form of the solution or, more easily, from the graphical solution for an infinite string subject to an initial displacement $Y(x)$.

A similar procedure is applicable in the case of a finite string of

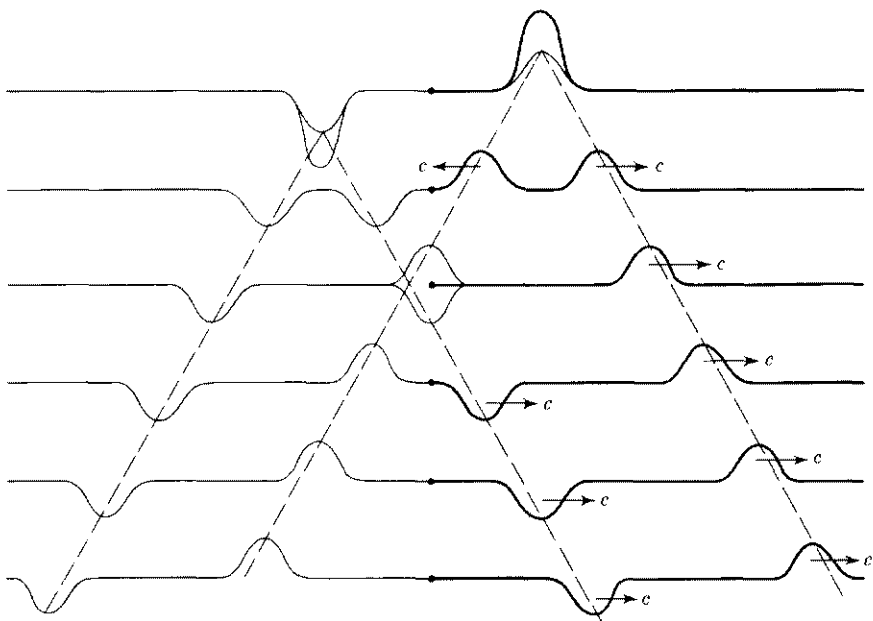

Figure 36

length l occupying the space $0 \leq x \leq l$. The initial conditions may then be written in the form

$$y = \eta(x), \quad \frac{\partial y}{\partial t} = v(x) \quad 0 \leq x \leq l \text{ at } t = 0$$

$$y = 0, \quad \frac{\partial y}{\partial t} = 0 \quad t \geq 0 \text{ at } x = 0 \text{ and } x = l$$

and by a method similar to the one above it is readily shown that the solution of the wave equation (1) satisfying these conditions is the

expression (8), where now the function $Y(x)$ is defined by the relations

$$Y(x) = \begin{cases} \eta(x) & \text{if } 0 \leq x \leq l \\ -\eta(-x) & \text{if } -l \leq x \leq 0 \end{cases}$$

$$Y(x + 2rl) = Y(x) \quad \text{if } -l \leq x \leq l \text{ and } r = \pm 1, \pm 2, \dots$$

In other words, $Y(x)$ is an odd periodic function of period $2l$. The relation between $\eta(x)$ and $Y(x)$ is shown graphically in Fig. 37. $V(x)$ is defined in terms of $v(x)$ in a precisely similar fashion.

It is well known from the theory of Fourier series¹ that such an odd

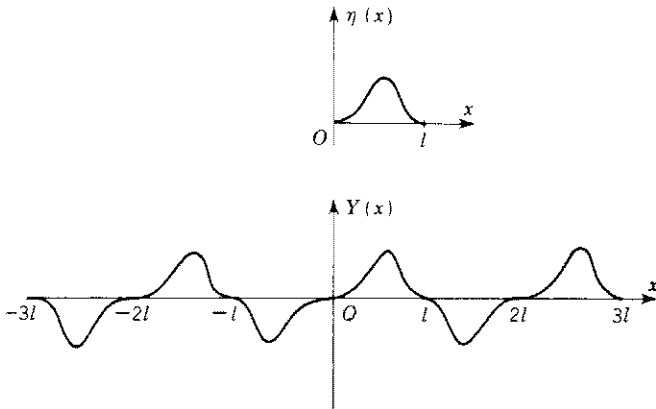

Figure 37

periodic function has a Fourier sine expansion of the form

$$Y(x) = \sum_{m=1}^{\infty} \eta_m \sin \frac{m\pi x}{l} \tag{10}$$

where the coefficients η_m are given by the formula

$$\eta_m = \frac{2}{l} \int_0^l \eta(\xi) \sin \left(\frac{m\pi \xi}{l} \right) d\xi \tag{11}$$

Similarly

$$V(x) = \sum_{m=1}^{\infty} v_m \sin \left(\frac{m\pi x}{l} \right) \tag{12}$$

where

$$v_m = \frac{2}{l} \int_0^l v(\xi) \sin \left(\frac{m\pi \xi}{l} \right) d\xi \tag{13}$$

Substituting the results

$$\frac{1}{2} \{ Y(x - ct) + Y(x + ct) \} = \sum_{m=1}^{\infty} \eta_m \sin \left(\frac{m\pi x}{l} \right) \cos \left(\frac{m\pi ct}{l} \right)$$

$$\frac{1}{2c} \int_{x-ct}^{x+ct} V(\xi) d\xi = \frac{l}{\pi c} \sum_{m=1}^{\infty} \frac{v_m}{m} \sin \left(\frac{m\pi x}{l} \right) \sin \left(\frac{m\pi ct}{l} \right)$$

¹ R. V. Churchill, "Fourier Series and Boundary Value Problems," (McGraw-Hill, New York, 1941), p. 75.

which follow from these expressions, into the solution (8), we find that the solution of the present problem is

$$y = \sum_{m=1}^{\infty} \eta_m \sin\left(\frac{m\pi x}{l}\right) \cos\left(\frac{m\pi ct}{l}\right) + \frac{l}{\pi c} \sum_{m=1}^{\infty} \frac{v_m}{m} \sin\left(\frac{m\pi x}{l}\right) \sin\left(\frac{m\pi ct}{l}\right) \quad (14)$$

where η_m and v_m are defined by equations (11) and (13), respectively.

Example 1. *The points of trisection of a string are pulled aside through a distance ϵ on opposite sides of the position of equilibrium, and the string is released from rest. Derive an expression for the displacement of the string at any subsequent time and show that the mid-point of the string always remains at rest.*

In this case we may take $l = 3a$ and

$$\eta(x) = \begin{cases} \frac{\epsilon x}{a} & 0 \leq x \leq a \\ \epsilon \frac{(3a - 2x)}{a} & a \leq x \leq 2a \\ \epsilon \frac{(x - 3a)}{a} & 2a \leq x \leq 3a \end{cases}$$

and $v(x) = 0$. Thus the Fourier coefficients are

$$\begin{aligned} \eta_m &= \frac{2\epsilon}{3a^2} \left(\int_0^a x \sin \frac{m\pi x}{3a} dx + \int_a^{2a} (3a - 2x) \sin \frac{m\pi x}{3a} dx + \int_{2a}^{3a} (x - 3a) \sin \frac{m\pi x}{3a} dx \right) \\ &= \frac{18\epsilon}{\pi^2 m^2} \{1 \cdots (-1)^m\} \sin\left(\frac{1}{3}m\pi\right) \end{aligned}$$

$$\text{and} \quad v_m = 0$$

so that the displacement is given by the expression

$$y = \frac{18\epsilon}{\pi^2} \sum_{m=1}^{\infty} \frac{1 \cdots (-1)^m}{m^2} \sin \frac{m\pi}{3} \sin \frac{m\pi x}{3a} \cos \frac{m\pi ct}{3a}$$

which is equivalent to

$$y = \frac{9\epsilon}{\pi^2} \sum_{n=1}^{\infty} \frac{1}{n^2} \sin \frac{2n\pi}{3} \sin \frac{2n\pi x}{3a} \cos \frac{2n\pi ct}{3a}$$

The displacement of the mid-point of the string is obtained by putting $x = 3a/2$ in this expression. Since $\sin(2n\pi/3a)$ would then equal $\sin n\pi$, and this is zero for all integral values of n , we see that the displacement of the mid-point of the string is always zero.

PROBLEMS

1. A uniform string of line density ρ is stretched to tension ρc^2 and executes a small transverse vibration in a plane through the undisturbed line of the string. The ends $x = 0, l$ of the string are fixed. The string is at rest, with the point $x = b$ drawn aside through a small distance ϵ and released at time $t = 0$. Show that at any subsequent time t the transverse displacement y is given by the Fourier expansion

$$y = \frac{2\epsilon l^2}{\pi^2 b(l-b)} \sum_{s=1}^{\infty} \frac{1}{s^2} \sin\left(\frac{s\pi b}{l}\right) \sin\left(\frac{s\pi x}{l}\right) \cos\left(\frac{s\pi ct}{l}\right)$$

2. If the string is released from rest in the position

$$y = \frac{4\epsilon}{l^2} x(l-x)$$

show that its motion is described by the equation

$$y = \frac{32\epsilon}{3} \sum_{n=0}^{\infty} \frac{1}{(2n+1)^3} \sin \frac{(2n-1)\pi x}{l} \cos \frac{(2n+1)\pi ct}{l}$$

3. If the string is released from rest in the position $y = f(x)$, show that the total energy of the string is

$$\frac{\pi^2 T}{4l} \sum_{s=1}^{\infty} s^2 k_s^2$$

where

$$k_s = \frac{2}{l} \int_0^l f(x) \sin \left(\frac{s\pi x}{l} \right) dx$$

The mid-point of a string is pulled aside through a small distance and then released. Show that in the subsequent motion the fundamental mode contributes $8/\pi^2$ of the total energy.

3. The Riemann-Volterra Solution of the One-dimensional Wave Equation

In Chap. 4 we saw that for Laplace's equation $\nabla_1^2 \psi = 0$ it is not possible to give independent prescribed values to both ψ and $\partial\psi/\partial n$ along a boundary curve, since if either ψ or $\partial\psi/\partial n$ is prescribed, that alone is sufficient to determine the potential function ψ uniquely. In the last section we saw that the corresponding situation for the one-dimensional wave equation

$$\frac{\partial^2 \psi}{\partial x^2} = \frac{\partial^2 \psi}{\partial y^2} \quad y = ct \tag{1}$$

is quite different; i.e., that ψ and $\partial\psi/\partial y$ can be prescribed independently along the line $y = 0$. We noted previously (Sec. 8 of Chap. 3) that if we are given the values of (x, y, z, p, q) along a strip C , then the equation

$$\frac{\partial^2 z}{\partial x \partial y} = f \left(x, y, \frac{\partial z}{\partial x}, \frac{\partial z}{\partial y} \right) \tag{2}$$

has an integral which takes on the given values of z, p, q along the curve Γ which is the projection of C on the xy plane, and a simple change of variable reduces equation (1) to the type (2). In this section we shall use the method of Riemann-Volterra outlined in Sec. 8 of Chap. 3 to determine the solution of the Cauchy problem

$$\frac{\partial^2 \psi}{\partial x^2} = \frac{\partial^2 \psi}{\partial y^2} \tag{3}$$

$$\psi = f(x, y), \quad \frac{\partial \psi}{\partial n} = g(x, y) \quad \text{on } C \tag{4}$$

where Γ is a curve with equation $u(x, y) = 0$.

Suppose that we wish to find the value $\psi(\xi, \eta)$ of the wave function ψ at a point P with coordinates (ξ, η) . Then it is readily shown that the characteristics of the equation (3) through the point P have equations

$$x + y = \xi + \eta \quad (5)$$

and

$$x - y = \xi - \eta \quad (6)$$

and we may assume that the second of these lines intersects the curve C in the point A and that the first intersects C in the point B (cf. Fig. 38). If we let

$$L = \frac{\partial^2}{\partial x^2} - \frac{\partial^2}{\partial y^2} \quad (7)$$

then, since this operator is self-adjoint, it follows from the generalized

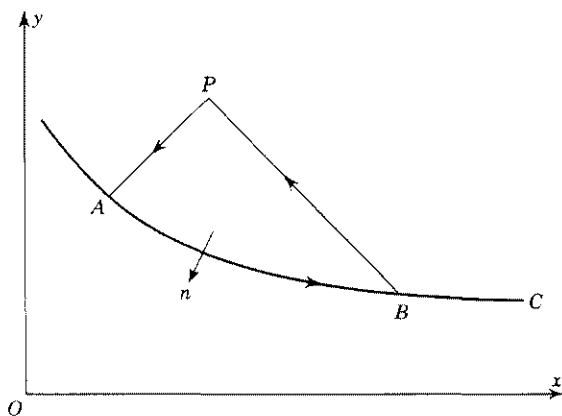

Figure 38

form of Green's theorem (Prob. 1 of Sec. 8 of Chap. 3) that

$$\iint_{\Sigma} (wL\psi - \psi Lw) dx dy = \int_{\Gamma} [U \cos(n, x) + V \cos(n, y)] ds \quad (8)$$

where

$$U = w \frac{\partial \psi}{\partial x} - \psi \frac{\partial w}{\partial x} \quad (9)$$

$$V = -w \frac{\partial \psi}{\partial y} + \psi \frac{\partial w}{\partial y} \quad (10)$$

C is the closed path $ABPA$, and Σ is the area enclosed by it. From the discussion of Sec. 8, Chap. 3 we see that the Green's function w must satisfy the conditions

(i) $Lw = 0$

(ii) $\frac{\partial w}{\partial n} = 0$ on AP and BP

(iii) $w = 1$ at the point P

These conditions are satisfied if we take $w \equiv 1$. Using this and the fact that $L\psi = 0$, we see that equation (8) reduces to

$$\left(\int_{PA} + \int_{AB} + \int_{BP} \right) \left[\frac{\partial \psi}{\partial x} \cos(n,x) - \frac{\partial \psi}{\partial y} \cos(n,y) \right] ds = 0 \quad (11)$$

On the characteristic PA , which has equation (6), we have

$$\cos(n,x) = \frac{-1}{\sqrt{2}}, \quad \cos(n,y) = \frac{1}{\sqrt{2}}, \quad ds = -\sqrt{2} dx = -\sqrt{2} dy$$

so that

$$\int_{PA} \left\{ \frac{\partial \psi}{\partial x} \cos(n,x) - \frac{\partial \psi}{\partial y} \cos(n,y) \right\} ds = \int_P^A \left(\frac{\partial \psi}{\partial x} dx + \frac{\partial \psi}{\partial y} dy \right) = \psi_A - \psi_P$$

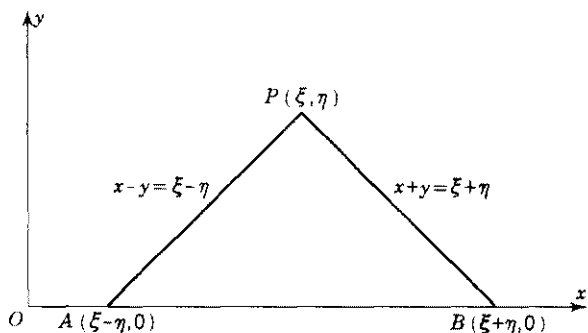

Figure 39

Similarly we have

$$\cos(n,x) = \frac{1}{\sqrt{2}}, \quad \cos(n,y) = \frac{1}{\sqrt{2}}, \quad ds = -\sqrt{2} dx = \sqrt{2} dy$$

along the characteristic PB , so that the value of the integral along the line BP is $\psi_B - \psi_P$. Substituting these values in the equation (11), we get

$$\psi_P = \frac{1}{2}(\psi_A + \psi_B) - \frac{1}{2} \int_{AB} \left(\frac{\partial \psi}{\partial x} \cos(x,n) - \frac{\partial \psi}{\partial y} \cos(y,n) \right) ds \quad (12)$$

as the solution of our Cauchy problem.

For instance, if we are given that

$$\psi = f(x), \quad \frac{\partial \psi}{\partial y} = g(x) \quad \text{on } y = 0 \quad (13)$$

then if P is the point (ξ, η) , it follows that A is $(\xi - \eta, 0)$ and B is $(\xi + \eta, 0)$ (cf. Fig. 39). We have

$$\psi_A = f(\xi - \eta), \quad \psi_B = f(\xi + \eta)$$

$$\int_{AB} \left(\frac{\partial \psi}{\partial x} \cos(x,n) - \frac{\partial \psi}{\partial y} \cos(y,n) \right) ds = - \int_{\xi-\eta}^{\xi+\eta} g(x) dx$$

If we substitute these expressions into equation (12), we obtain d'Alembert's solution (cf. equation (5) of Sec. 2).

It follows from the Riemann-Volterra solution (12) that if an initial disturbance, either a displacement or a velocity, is concentrated near the point (x_0, y_0) , it can influence only that infinite sector of the half plane $y > y_0$ formed by the two lines of gradient ± 1 passing through

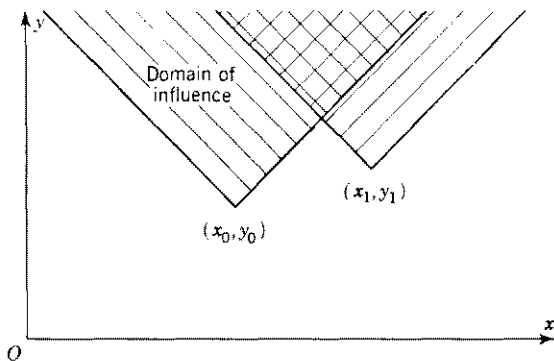

Figure 40

the point. This sector is called the initial domain of influence of (x_0, y_0) (cf. Fig. 40). In a similar way we can construct the domain of influence of another point (x_1, y_1) , and a simple diagram, e.g., Fig. 40, shows that all domains of influence intersect for $y > 0$. In a similar way we define

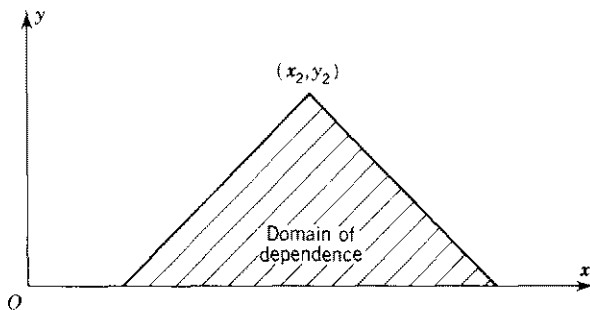

Figure 41

the domain of dependence of a point (x_2, y_2) as the set of all points with $y > 0$ whose domain of influence includes the point (x_2, y_2) (cf. Fig. 41). It is easily seen that the domain of dependence of a point is the triangle cut off from the upper half of the xy plane by the two downward-drawn lines through (x_2, y_2) of gradient ± 1 . These lines if produced upward would bound the domain of influence of the point (x_2, y_2) . Since we do not, in general, consider points with $y < 0$, i.e., events in the past,

it follows that it is possible to have nonintersecting domains of dependence. Consider two points (x, y) and (x', y') whose time coordinates are equal. If their domains of dependence do not intersect, then the displacements at the points will be incoherent: they will be caused by initial displacements and velocities which are completely independent of one another.

PROBLEMS

1. If

$$\psi = f(\nu), \quad \frac{\partial \psi}{\partial x} = g(\nu)$$

at a point which is moving with constant velocity βc ($\beta < 1$) starting at $x = 0$ at $y = 0$, show that this implies that

$$\frac{\partial \psi}{\partial y} = f'(\nu) - \beta g(\nu)$$

and show that

$$\psi(\xi, \eta) = \frac{1}{2}(1 + \beta)f\left(\frac{\xi - \eta}{1 - \beta}\right) + \frac{1}{2}(1 - \beta)f\left(\frac{\eta - \xi}{1 - \beta}\right) - \frac{1}{2}(1 - \beta^2) \int_a^b g(y) dy$$

where $b = (\xi + \eta)/(1 - \beta)$, $a = (\eta - \xi)/(1 - \beta)$.

2. Using the results of the last problem show that the wave function corresponding to a traveling source of sound of frequency p is

$$\psi(x, t) = \frac{c}{2p}(1 - \beta^2) \left[\sin\left\{\frac{p(t + x/c)}{1 - \beta}\right\} - \sin\left\{\frac{p(t - x/c)}{1 - \beta}\right\} \right]$$

Interpret the result physically.

3. A function ψ satisfies the nonhomogeneous wave equation

$$\frac{\partial^2 \psi}{\partial x^2} - \frac{\partial^2 \psi}{\partial y^2} = f(x, y) = 0$$

and the initial conditions

$$\psi = \frac{\partial \psi}{\partial y} = 0 \quad \text{when } y = 0$$

Show that

$$\psi(x, y) = \frac{1}{2} \iint_T f(u, v) du dv$$

where T is the triangle cut out from the upper half of the uv plane by the two characteristics through the point (x, y) .

4. If ψ is determined by the differential equation

$$a^2 \frac{\partial^2 \psi}{\partial x^2} - b^2 \psi = \frac{\partial^2 \psi}{\partial y^2}$$

where a and b are constants, and by the conditions

$$y = 0, \quad \psi = f(x), \quad \frac{\partial \psi}{\partial y} = g(x)$$

show by the Riemann-Volterra method¹ that

$$\begin{aligned} v(x, y) &= \frac{1}{2} \{ f(x-a, y) + f(x+a, y) \} \\ &- \frac{1}{2a} \int_x^{x+a} \int_y^{y+a} g(\xi) J_0 \left(\frac{b}{a} \sqrt{(\xi-x)^2 + a^2 y^2} \right) d\xi \\ &+ \frac{1}{2} b y \int_x^{x+a} \int_y^{y+a} f(\xi) \frac{J_0' \left[(b/a) \sqrt{(\xi-x)^2 + a^2 y^2} \right] d\xi}{\sqrt{(\xi-x)^2 + a^2 y^2}} \end{aligned}$$

4. Vibrating Membranes: Application of the Calculus of Variations

We saw in subdivision (e) of Sec. 1 that the transverse vibrations of a thin membrane S bounded by the curve Γ in the xy plane could be described by a function $z(x, y, t)$ satisfying the wave equation

$$\nabla_1^2 z = \frac{1}{c^2} \frac{\partial^2 z}{\partial t^2} \quad (1)$$

the boundary condition

$$z = 0 \quad \text{on } \Gamma \text{ for all } t \quad (2)$$

and the initial conditions

$$z = f(x, y), \quad \frac{\partial z}{\partial t} = g(x, y) \quad t = 0, \quad (x, y) \in S \quad (3)$$

The two main techniques for the direct solution of this boundary value problem are the theory of integral transforms and the method of separation of variables. The first of these methods is particularly useful when the membrane is of infinite extent, and the second is useful when the boundary curve Γ has a simple form.

We shall illustrate the use of the theory of integral transforms to problems of this kind by:

Example 2. *A thin membrane of great extent is released from rest in the position $z = f(x, y)$. Determine the displacement at any subsequent time.*

Here we have to solve equation (1) subject to the conditions

$$z = f(x, y), \quad \frac{\partial z}{\partial t} = 0 \quad (4)$$

at $t = 0$ for all (x, y) of the plane. To solve this initial value problem we multiply both sides of equation (1) by $\exp\{i(\xi x + \eta y)\}$ and integrate over the entire xy plane. Then using the results

$$\frac{1}{2\pi} \int_{-\infty}^{\infty} \int_{-\infty}^{\infty} \left(\frac{\partial^2 z}{\partial x^2}, \frac{\partial^2 z}{\partial y^2}, \frac{\partial^2 z}{\partial t^2} \right) e^{i(\xi x + \eta y)} dx dy = \left(-\xi^2, -\eta^2, \frac{d^2}{dt^2} \right) Z$$

where $Z(\xi, \eta; t) = \frac{1}{2\pi} \int_{-\infty}^{\infty} \int_{-\infty}^{\infty} z(x, y; t) e^{i(\xi x + \eta y)} dx dy$

¹ Cf. Prob. 4, Sec. 8, Chap. 3.

is the two-dimensional Fourier transform of $Z(x, y, t)$, we see that equation (1) is equivalent to

$$\frac{d^2 Z}{dt^2} - c^2(\xi^2 + \eta^2)Z = 0 \quad (5)$$

and the conditions (4) are equivalent to the pair

$$Z = F(\xi, \eta), \quad \frac{dZ}{dt} = 0 \quad t = 0 \quad (6)$$

Solving (5) subject to (6), we find that

$$Z = F(\xi, \eta) \cos [c(\xi^2 + \eta^2)^{1/2} t]$$

By a double application of Fourier's inversion theorem (see p. 128) we have therefore

$$z = \frac{1}{2\pi} \int_{-\infty}^{\infty} \int_{-\infty}^{\infty} F(\xi, \eta) \cos [c(\xi^2 + \eta^2)^{1/2} t] e^{-i(\xi x + \eta y)} d\xi d\eta \quad (7)$$

so that the problem is reduced to two double integrations, the evaluation of $F(\xi, \eta)$ and the evaluation of (7) (cf. Prob. 1 and 2 below).

The use of the method of separation of variables will be illustrated in two cases, when Γ is a rectangle and when it is a circle.

When Γ is the rectangle formed by the lines $x = 0$, $x = a$, $y = 0$, $y = b$, it is natural to assume solutions of equation (1) of the form

$$z = X(x)Y(y)e^{\pm ikt}$$

We then find, on substituting into equation (1), that

$$\frac{X''}{X} + \frac{Y''}{Y} + k^2 = 0$$

showing that the ordinary differential equations for X , Y are

$$X'' + k_1^2 X = 0, \quad Y'' + k_2^2 Y = 0$$

where

$$k_1^2 + k_2^2 = k^2 \quad (8)$$

We therefore get solutions of the form

$$z = A_{k_1 k_2} e^{\pm i(k_1 x + k_2 y + kt)} \quad (9)$$

Since z must vanish when $x = 0$, $x = a$, $y = 0$, $y = b$, we must take solutions of the form

$$z = \sum_{m, n} A_{mn} \sin\left(\frac{m\pi x}{a}\right) \sin\left(\frac{n\pi y}{b}\right) e^{\pm ik_{mn} ct}$$

where m , n are integers and

$$k_{mn}^2 = \pi^2 \left(\frac{m^2}{a^2} + \frac{n^2}{b^2} \right) \quad (10)$$

For instance, if

$$z = f(x, y), \quad \frac{\partial z}{\partial t} = 0 \quad \text{at } t = 0$$

then the appropriate solution is

$$z(x, y, t) = \sum_{m, n} A_{mn} \sin\left(\frac{m\pi x}{a}\right) \sin\left(\frac{n\pi y}{b}\right) \cos(k_{mn} ct) \quad (11)$$

where k_{mn} is given by equation (10) and the coefficients A_{mn} are chosen so that

$$f(x, y) = \sum_{m, n} A_{mn} \sin\left(\frac{m\pi x}{a}\right) \sin\left(\frac{n\pi y}{b}\right) \quad 0 \leq x \leq a, 0 \leq y \leq b$$

$$\text{i.e.,} \quad A_{mn} = \frac{4}{ab} \int_0^a \int_0^b f(x, y) \sin\left(\frac{m\pi x}{a}\right) \sin\left(\frac{n\pi y}{b}\right) dx dy \quad (12)$$

The complete solution is therefore given by equations (10), (11), and (12). The frequencies of possible oscillations are given by equation (10). These quantities are known as the *eigenvalues* of k . It is only when k takes one of that set of values that the problem has a solution of the form (9).

When the boundary curve Γ is a circle of radius a , it is best to transform to plane polar coordinates r, θ , in which case equation (1) assumes the form

$$\frac{\partial^2 z}{\partial r^2} + \frac{1}{r} \frac{\partial z}{\partial r} + \frac{1}{r^2} \frac{\partial^2 z}{\partial \theta^2} = \frac{1}{c^2} \frac{\partial^2 z}{\partial t^2} \quad (13)$$

and the curve Γ can be taken as $r = a$. If we assume a solution of this equation of the form

$$z = R(r)\Theta(\theta)e^{\pm ikt}$$

we find that the functions R, Θ must be such that

$$\frac{r^2}{R} \left[\frac{d^2 R}{dr^2} + \frac{1}{r} \frac{dR}{dr} + k^2 R \right] \div \frac{1}{\Theta} \frac{d^2 \Theta}{d\theta^2} = 0$$

showing that the ordinary differential equations for R, Θ are

$$\frac{d^2 \Theta}{d\theta^2} + m^2 \Theta = 0 \quad (14)$$

$$\text{and} \quad \frac{d^2 R}{dr^2} + \frac{1}{r} \frac{dR}{dr} + \left(k^2 - \frac{m^2}{r^2} \right) R = 0 \quad (15)$$

The solutions of (14) are of the form

$$\Theta = e^{\pm im\theta}$$

If the displacement $z(r, \theta, t)$ is to have the obvious physical property that $z(r, \theta + 2\pi, t) = z(r, \theta, t)$, then we must choose m to be an *integer*. Furthermore, since for physical reasons we are interested only in solutions which remain finite at $r = 0$, we must take the solution of (15) to be of the form

$$R = J_m(kr)$$

where $J_m(x)$ denotes the Bessel function of the first kind of order m and

argument x .† In this way we build up solutions of the equation (13) of the form

$$z = \sum_{m,k} A_{mk} J_m(kr) e^{\pm im\theta - ikct} \quad (16)$$

If z vanishes on the circle $r = a$, then the numbers k must be chosen so that

$$J_m(ka) = 0 \quad (17)$$

and we finally get solutions of the type

$$z = \sum_{m,n} A_{mn} J_m(k_{mn}r) \exp \{ \pm im\theta \pm ik_{mn}ct \} \quad (18)$$

where A_{mn} are constants and k_{m1}, k_{m2}, \dots are the positive roots of the transcendental equation (17). In the symmetrical case in which z is a function of r and t alone the corresponding solution is

$$z(r,t) = \sum_n A_n J_0(k_n r) e^{\pm ik_n t} \quad (19)$$

where k_1, k_2, \dots are the positive zeros of the function $J_0(ka)$.

For instance, if we are given that

$$z = f(r), \quad \frac{\partial z}{\partial t} = 0 \quad \text{at } t = 0$$

then the solution of the problem is

$$z = \sum_n A_n J_0(k_n r) \cos(k_n ct) \quad (20)$$

where the constants A_n are chosen so that

$$f(r) = \sum_n A_n J_0(k_n r)$$

From the theory of Bessel functions¹ we see that this implies that

$$A_n = \frac{2}{a_2 J_1^2(k_n a)} \int_0^a r f(r) J_0(k_n r) dr \quad (21)$$

The complete solution of our problem is therefore given by the equations (20) and (21).

Solutions of problems of these kinds relating to vibrating membranes with rectangular and circular boundaries can also be derived by means of the theory of "finite" transforms. For details of the derivation of these solutions the reader is referred to Sec. 19.5 and 19.6 of Sneddon's "Fourier Transforms" (McGraw-Hill, New York, 1951).

These methods are appropriate only when the boundary curve Γ has

† Cf. I. N. Sneddon, "The Special Functions of Physics and Chemistry" (Oliver & Boyd, Edinburgh, 1956), p. 103.

¹ G. N. Watson, "A Treatise on the Theory of Bessel Functions," 2d. ed. (Cambridge, London, 1944), chap. XVIII.

a simple form. When Γ is a more complicated boundary, approximate values of the possible frequencies of the system can be found by making use of certain results in the calculus of variations. According to the calculus of variations,¹ if the solution of equation (1) in the case in which Γ is fixed is of the form $f(x, y) e^{i t \sqrt{\lambda}}$, then the n th eigenvalue λ_n is the minimum of the integral

$$I = T \iint_S \left\{ \left(\frac{\partial \phi}{\partial x} \right)^2 + \left(\frac{\partial \phi}{\partial y} \right)^2 \right\} dx dy \quad (22)$$

with respect to those sufficiently regular functions ϕ which vanish on Γ and satisfy the normalization condition

$$\sigma \iint_S \phi^2 dx dy = 1 \quad (23)$$

and the $n - 1$ orthogonality relations

$$\iint_S \phi \phi_m dx dy = 0 \quad (24)$$

where ϕ_m is the minimizing function which makes I equal to λ_m .

This provides us with a method of determining approximate solutions to our problem.² If

$$z = \psi_m(x, y) e^{i k_m c t} \quad (25)$$

is an approximate solution of the problem stated in equations (1) and (2), then if Φ_1, \dots, Φ_n are n functions which are continuously differentiable in S and which vanish on Γ , an approximate solution is

$$\psi_m(x, y) = \sum_{i=1}^n C_i^{(m)} \Phi_i(x, y) \quad (26)$$

where the coefficients $C_i^{(m)}$ are the solutions of the linear algebraic equations

$$\sum_{j=1}^n (\sigma_{ij} k_m^2 - \Gamma_{ij}) C_j^{(m)} = 0 \quad i = 1, 2, \dots, n \quad (27)$$

with

$$\sigma_{ij} = \sigma_{ji} = \iint_S \Phi_i \Phi_j dx dy \quad (28)$$

$$\Gamma_{ij} = \Gamma_{ji} = \iint_S \left(\frac{\partial \Phi_i}{\partial x} \frac{\partial \Phi_j}{\partial x} + \frac{\partial \Phi_i}{\partial y} \frac{\partial \Phi_j}{\partial y} \right) dx dy \quad (29)$$

and the first n approximate eigenvalues k_1, k_2, \dots, k_n are given by

¹ R. Weinstock, "Calculus of Variations" (McGraw-Hill, New York, 1952), pp. 164-167.

² *Ibid.*, pp. 188-191.

the n positive roots of the determinantal equation

$$\begin{vmatrix} \sigma_{11}k^2 - \Gamma_{11} & \sigma_{12}k^2 - \Gamma_{12} & \cdots & \sigma_{1n}k^2 - \Gamma_{1n} \\ \sigma_{21}k^2 - \Gamma_{21} & \sigma_{22}k^2 - \Gamma_{22} & \cdots & \sigma_{2n}k^2 - \Gamma_{2n} \\ \vdots & \vdots & \ddots & \vdots \\ \sigma_{n1}k^2 - \Gamma_{n1} & \sigma_{n2}k^2 - \Gamma_{n2} & \cdots & \sigma_{nn}k^2 - \Gamma_{nn} \end{vmatrix} = 0 \quad (30)$$

In addition the coefficients must be chosen to satisfy the normalization condition

$$\sigma \sum_{i,j=1}^n C_i^{(m)} C_j^{(m)} \sigma_{ij} = 1 \quad (31)$$

If the boundary curve Γ of the membrane S has equation $u(x,y) = 0$, a simple choice of the approximate functions Φ_i ($i = 1, 2, \dots, n$) is to take

$$\begin{aligned} \Phi_1 &= u(x,y), & \Phi_2 &= xu(x,y), & \Phi_3 &= yu(x,y) \\ \Phi_4 &= x^2u(x,y), & \Phi_5 &= xyu(x,y), & \Phi_6 &= y^2u(x,y), \text{ etc.} \end{aligned}$$

The variational approach to eigenvalue problems is useful not only in the derivation of approximate solutions but also in the establishing of quite general theorems about the eigenvalues of a system. For details of such theorems the reader is referred to Chap. 9 of the book by Weinstock mentioned above and also to Chap. 6 of Vol. I of "Methoden der mathematischen Physik" (Springer, Berlin, 1924), by R. Courant and D. Hilbert.

Example 3. Find approximate values for the first three eigenvalues of a square membrane of side 2.

Suppose we take the membrane to be bounded by the lines $x = \pm 1, y = \pm 1$; then we may assume

$$\Phi_1 = (1 - x^2)(1 - y^2), \quad \Phi_2 = x(1 - x^2)(1 - y^2), \quad \Phi_3 = y(1 - x^2)(1 - y^2)$$

and we find that

$$\begin{aligned} \sigma_{11} &= \frac{256}{225}, & \sigma_{22} = \sigma_{33} &= \frac{256}{1575}, & \sigma_{12} = \sigma_{23} = \sigma_{31} &= 0 \\ \Gamma_{11} &= \frac{256}{45}, & \Gamma_{22} = \Gamma_{33} &= \frac{3328}{1575}, & \Gamma_{12} = \Gamma_{23} = \Gamma_{31} &= 0 \end{aligned}$$

In this case the determinantal equation (30) reduces to

$$(k^2 - 5)(k^2 - 13)^2 = 0$$

so that the first three approximate eigenvalues of the square are

$$k_1 = \sqrt{5} = 2.236, \quad k_2 = k_3 = \sqrt{13} = 3.606$$

From equation (10) we see that the exact results are

$$k_1 = \frac{\pi \sqrt{2}}{2} = 2.221, \quad k_2 = k_3 = \frac{\pi \sqrt{5}}{2} = 3.942$$

PROBLEMS

1. Show that the solution of Example 2 can be put in the form

$$z(x, y, t) = -\frac{1}{2\pi c} \int_{-\infty}^{\infty} \int_{-\infty}^{\infty} \frac{\partial}{\partial t} \frac{f(x, y) dx dy}{\sqrt{c^2 t^2 - (x - \alpha)^2 - (y - \beta)^2}}$$

2. A very large membrane which is in its equilibrium position lies in the shape $z = f(r)$ ($r^2 = x^2 + y^2$). Show that its subsequent displacement is given by the equation

$$z(r, t) = \int_0^{\infty} \xi \bar{f}(\xi) \cos(c\xi t) J_0(\xi r) d\xi$$

where
$$\bar{f}(\xi) = \int_0^{\infty} r f(r) J_0(\xi r) dr$$

3. A square membrane whose edges are fixed receives a blow in such a way that a concentric and similarly situated square area one-sixteenth of the area of the membrane acquires a transverse velocity v without sensible displacement, the remainder being undisturbed. Find a series for the displacement of the membrane at any subsequent time.
4. A membrane of uniform density σ per unit area is stretched on a circular frame of radius a to uniform stress σc^2 .

When $t = 0$, the membrane is released from rest in the position $x = \varepsilon(a^2 - r^2)$, where ε is small, and r is the distance from the center. Show that the displacement of the center at time t is

$$8\varepsilon a^2 \sum_{n=1}^{\infty} \frac{\cos(\xi_n ct/a)}{\xi_n J_1(\xi_n)}$$

where ξ_n is the n th positive zero of the Bessel function J_0 .

5. Using the approximations

$$\Phi_1 = 1 - \sqrt{x^2 + y^2}, \quad \Phi_2 = x - x\sqrt{x^2 + y^2}, \quad \Phi_3 = y - y\sqrt{x^2 + y^2}$$

show that the first three approximate values of the constant k in the solution $f(r)e^{ikt}$, describing the transverse vibrations of a circular membrane of unit radius, are

$$K_1 = \sqrt{6}, \quad K_2 = K_3 = \sqrt{15}$$

5. Three-dimensional Problems

In this section we shall consider some of the simple solutions of the three-dimensional wave equation

$$\nabla^2 \psi = \frac{1}{c^2} \frac{\partial^2 \psi}{\partial t^2} \quad (1)$$

It is a simple matter to show that this equation has solutions of the form

$$\exp\{\pm i(lx + my + nz + kct)\} \quad (2)$$

provided that

$$k^2 = l^2 + m^2 + n^2 \quad (3)$$

Example 4. A gas is contained in a cubical box of side a . Show that if c is the velocity of sound in the gas, the periods of free oscillations are

$$\frac{2a}{c \sqrt{n_1^2 + n_2^2 + n_3^2}}$$

where n_1, n_2, n_3 are integers.

In this problem we are looking for solutions of the wave equation (1) valid in the space $0 \leq (x, y, z) \leq a$ and such that $\partial\psi/\partial n = 0$ on the boundaries of the cube. The form of ψ will therefore be

$$\psi(x, y, z, t) = \sum_{n_1, n_2, n_3} A_{n_1, n_2, n_3} \cos\left(\frac{n_1\pi x}{a}\right) \cos\left(\frac{n_2\pi y}{a}\right) \cos\left(\frac{n_3\pi z}{a}\right) \cos\left[(n_1^2 + n_2^2 + n_3^2)^{\frac{1}{2}} \frac{\pi ct}{a}\right]$$

where n_1, n_2, n_3 are integers. It follows immediately that the periods of the free oscillations of the gas are

$$\frac{2a}{c \sqrt{n_1^2 + n_2^2 + n_3^2}}$$

In spherical polar coordinates r, θ, ϕ the wave equation (1) assumes the form

$$\frac{\partial^2\psi}{\partial r^2} + \frac{2}{r} \frac{\partial\psi}{\partial r} + \frac{1}{r^2 \sin\theta} \frac{\partial}{\partial\theta} \left(\sin\theta \frac{\partial\psi}{\partial\theta} \right) + \frac{1}{r^2 \sin^2\theta} \frac{\partial^2\psi}{\partial\phi^2} = \frac{1}{c^2} \frac{\partial^2\psi}{\partial t^2} \quad (4)$$

If we let

$$\psi(r, \theta, \phi) = \Psi(r) P_n^m(\cos\theta) e^{\pm im\phi \pm ikt} \quad (5)$$

where $\Psi(r)$ is a function of r and $P_n^m(\cos\theta)$ is the associated Legendre function, then on substituting from equation (5) into equation (4) we find that $\Psi(r)$ satisfies the ordinary differential equation

$$\frac{d^2\Psi}{dr^2} + \frac{2}{r} \frac{d\Psi}{dr} - \frac{n(n+1)}{r^2} \Psi + k^2\Psi = 0 \quad (6)$$

Now, putting

$$\Psi = r^{-\frac{1}{2}} R(r)$$

we see that equation (6) reduces to

$$\frac{d^2R}{dr^2} + \frac{1}{r} \frac{dR}{dr} + \left\{ k^2 - \frac{(n + \frac{1}{2})^2}{r^2} \right\} R = 0 \quad (7)$$

from which it follows that if $n + \frac{1}{2}$ is neither zero nor an integer,

$$R(r) = AJ_{n+\frac{1}{2}}(kr) + BJ_{-n-\frac{1}{2}}(kr) \quad (8)$$

where A and B are constants and $J_\nu(z)$ denotes the Bessel function of the first kind of order ν and argument z . If on physical grounds we require the solution (5) to have the symmetry properties

$$\psi(r, \theta + \pi, \phi) = \psi(r, \theta, \phi), \quad \psi(r, \theta, \phi + 2\pi) = \psi(r, \theta, \phi)$$

then we must take m and n to be integers.

Hence the function

$$\psi(r, \theta, \phi) = r^{-\frac{1}{2}} J_{\frac{1}{2}(n-\frac{1}{2})}(kr) P_n^m(\cos \theta) e^{-im\phi - ikt} \quad (9)$$

is a solution of the wave equation (4). The functions $J_{\frac{1}{2}(n-\frac{1}{2})}(kr)$, which occur in the solution (9), are called *spherical Bessel functions*.¹ They are related in a simple fashion to the trigonometric functions, for it can be shown that if n is half of an odd integer

$$J_n(x) = \left(\frac{2}{\pi x}\right)^{\frac{1}{2}} [f_n(x) \sin x - g_n(x) \cos x]$$

$$J_{-n}(x) = \left(\frac{2}{\pi x}\right)^{\frac{1}{2}} (-1)^{n-\frac{1}{2}} [g_n(x) \sin x + f_n(x) \cos x]$$

where $f_n(x)$ and $g_n(x)$ are polynomials in x^{-1} , e.g., in the case $n = \frac{1}{2}$, $f_{\frac{1}{2}}(x) = 1$, $g_{\frac{1}{2}}(x) = 0$ and for $n = \frac{3}{2}$, $f_{\frac{3}{2}}(x) = 1/x$ and $g_{\frac{3}{2}}(x) = 1$. It follows from these facts that

$$\psi(r) = \frac{1}{r} e^{\pm ikr \pm ikt} \quad (10)$$

$$\psi(r, \theta) = \frac{1}{r} \left[\frac{\sin(kr)}{kr} - \cos(kr) \right] \cos \theta e^{\pm ikt} \quad (11)$$

are particular solutions of the wave equation (1).²

The solution (10) is a particular case of a more general solution which can be derived directly from equation (1). If the solution of the wave equation is assumed to have spherical symmetry, i.e., if ψ is a function only of r and t , then it must satisfy the equation

$$\frac{\partial^2 \psi}{\partial r^2} + \frac{2}{r} \frac{\partial \psi}{\partial r} = \frac{1}{c^2} \frac{\partial^2 \psi}{\partial t^2} \quad (12)$$

If we put $\psi = \phi/r$, we find that

$$\frac{\partial^2 \phi}{\partial r^2} = \frac{1}{c^2} \frac{\partial^2 \phi}{\partial t^2}$$

so that

$$\phi = f(r - ct) + g(r + ct)$$

where the functions f and g are arbitrary. In other words, the general solution of the equation (12) is

$$\psi = \frac{1}{r} [f(r - ct) + g(r + ct)] \quad (13)$$

where the functions f and g are arbitrary.

¹ I. N. Sneddon, "The Special Functions of Physics and Chemistry" (Oliver & Boyd, Edinburgh, 1956), sec. 31.

² For applications of the wave functions (9) to electromagnetic theory the reader is referred to J. A. Stratton, "Electromagnetic Theory" (McGraw-Hill, New York, 1941), chap. VII.

The function $r^{-1}f(r - ct)$ represents a diverging wave. If we take

$$\phi = \frac{1}{4\pi r} f\left(t - \frac{r}{c}\right) \tag{14}$$

to be the velocity potential of a gas, then the velocity of the gas is

$$u = -\frac{\partial\phi}{\partial r} = \frac{1}{4\pi r^2} f\left(t - \frac{r}{c}\right) + \frac{1}{4\pi rc} f'\left(t - \frac{r}{c}\right)$$

so that the total flux through a sphere of center the origin and small radius ϵ is

$$4\pi\epsilon^2 u = f(t) + O(\epsilon)$$

For this reason we say that there is a point source of strength $f(t)$ situated at the origin; the expression (14) therefore represents the velocity potential of such a source. The difference between the pressure at an instant t and the equilibrium value is given by

$$p - p_0 = \rho \frac{\partial\phi}{\partial t} = \frac{\rho}{4\pi r} f'\left(t - \frac{r}{c}\right) \tag{15}$$

Example 5. A gas is contained in a rigid sphere of radius a . Show that if c is the velocity of sound in the gas, the frequencies of purely radial oscillations are $c\xi_i/a$, where ξ_1, ξ_2, \dots are the positive roots of the equation $\tan \xi = \xi$.

The conditions to be satisfied by the wave function ψ are that it satisfies equation (12), that ψ remains finite at the origin, and that $u = \partial\psi/\partial r = 0$ at $r = a$. From equation (10) we see that the first two of these conditions is satisfied if we take

$$\psi = A \frac{\sin(kr)}{r} e^{ikct}$$

where A is a constant. For this function

$$u = -\frac{\partial\psi}{\partial r} = A \left[\frac{k \cos(kr)}{r} - \frac{\sin(kr)}{r^2} \right] e^{ikct}$$

so that $u = 0$ on $r = a$ if k is chosen so that

$$\tan(ka) = ka$$

The possible frequencies are therefore given by the expression $c\xi_i/a$ ($i = 1, 2, \dots$), where ξ_1, ξ_2, \dots are the positive roots of the transcendental equation

$$\tan \xi = \xi \tag{16}$$

Similar solutions of the wave equation (1) can be found when the coordinates are taken to be cylindrical coordinates (ρ, ϕ, z) . The wave equation then takes the form

$$\frac{\partial^2\psi}{\partial\rho^2} + \frac{1}{\rho} \frac{\partial\psi}{\partial\rho} + \frac{1}{\rho^2} \frac{\partial^2\psi}{\partial\phi^2} + \frac{\partial^2\psi}{\partial z^2} = \frac{1}{c^2} \frac{\partial^2\psi}{\partial t^2} \tag{17}$$

If we write

$$\psi(\rho, \phi, z, t) = R(\rho)\Phi(\phi)Z(z)T(t)$$

we see immediately that the equation (17) separates into

$$\frac{d^2 R}{dr^2} + \frac{1}{r} \frac{dR}{dr} - \left(\omega^2 - \frac{m^2}{r^2} \right) R = 0$$

$$\frac{d^2 \Phi}{d\phi^2} + m^2 \Phi = 0, \quad \frac{d^2 Z}{dz^2} + \gamma^2 Z = 0, \quad \frac{d^2 T}{dt^2} + k^2 c^2 T = 0$$

where $\gamma^2 = k^2 - \omega^2$ (18)

We therefore have solutions of the form

$$\psi(\rho, \phi, z, t) = J_m(\omega\rho) e^{i(m\phi - \gamma z - imt)} \quad (19)$$

where γ is related to k and ω through the equation (18). If $k > \omega$, so that γ is real, we can think of the solution (19) as representing a wave of amplitude $J_m(\omega\rho) e^{-im\phi}$ moving along the z axis. The phase velocity of such a wave is

$$V = \frac{kc}{\gamma}$$

and the group velocity¹ is

$$W = \frac{d}{d\gamma}(kc) = \frac{c\gamma}{k}$$

Example 6. Harmonic sound waves of period $2\pi/kc$ and small amplitude are propagated along a circular wave guide bounded by the cylinder $\rho = a$. Prove that solutions independent of the angle variable ϕ are of the form

$$\psi = e^{i(kct - \gamma z)} J_0\left(\frac{\xi_n \rho}{a}\right)$$

where ξ_n is a zero of $J_1(\xi)$ and $\gamma^2 = k^2 - (\xi_n^2/a^2)$.

Show that this mode is propagated only if $k > \xi_n/a$.

Since ψ is independent of ϕ , it follows that we must take $m = 0$ in equation (19) to obtain

$$\psi = J_0(\omega\rho) e^{i(kct - \gamma z)}$$

where $\gamma^2 = k^2 - \omega^2$. The boundary condition is that the velocity of the gas vanishes on the cylinder; i.e.,

$$\frac{\partial \psi}{\partial \rho} = 0 \quad \text{on } \rho = a \quad (20)$$

Since $J_0'(x) = -J_1(x)$, it follows that this condition is satisfied only if ω is chosen to be such that $J_1(\omega a) = 0$; $\omega = \xi_n/a$, where ξ_1, ξ_2, \dots are the zeros of $J_1(\xi)$. We therefore have

$$\psi = e^{i(kct - \gamma z)} J_0\left(\frac{\xi_n \rho}{a}\right) \quad (21)$$

where $\gamma^2 = k^2 - (\xi_n^2/a^2)$.

For the mode given by equation (21) to be propagated we must have γ real; i.e., $k > \xi_n/a$.†

¹ C. A. Coulson, "Waves" (Oliver & Boyd, Edinburgh, 1941), p. 130.

† For the application of the theory of cylindrical waves in electromagnetic theory the reader is referred to Stratton, *op. cit.*, chap. VI.

The solution (19) is useful in applications to problems in which the physical conditions impose the restriction that ψ must remain finite when $\rho \rightarrow 0$. In problems in which there is no such requirement we must take as our solution

$$\psi(\rho, \phi, z, t) = [A_m J_m(\omega\rho) + B_m Y_m(\omega\rho)] e^{ikct - iz - im\phi} \quad (22)$$

where $Y_m(\omega\rho)$ denotes Bessel's function of the second kind¹ and A_m, B_m denote complex constants. The most convenient solutions of Bessel's equation to use in this connection are Hankel functions

$$H_m^{(1)}(\omega\rho) = J_m(\omega\rho) + iY_m(\omega\rho), \quad H_m^{(2)}(\omega\rho) = J_m(\omega\rho) - iY_m(\omega\rho)$$

so that we may write the solution (22) in the form

$$\psi(\rho, \phi, z, t) = [A_m H_m^{(1)}(\omega\rho) + B_m H_m^{(2)}(\omega\rho)] e^{ikct - iz - im\phi} \quad (23)$$

For instance, in the case of axial symmetry ($m = 0$) we obtain solutions of the form

$$\psi(\rho, z, t) = [AH_0^{(1)}(\omega\rho) + BH_0^{(2)}(\omega\rho)] e^{ikct - iz} \quad (24)$$

Now for large values of ρ

$$H_0^{(1)}(\omega\rho) \sim \left(\frac{2}{\pi\omega\rho}\right)^{\frac{1}{2}} e^{i(\omega\rho - \frac{1}{2}\pi)}, \quad H_0^{(2)}(\omega\rho) \sim \left(\frac{2}{\pi\omega\rho}\right)^{\frac{1}{2}} e^{-i(\omega\rho - \frac{1}{2}\pi)} \quad (25)$$

so as $\rho \rightarrow \infty$,

$$\psi(\rho, z, t) \sim \left(\frac{2}{\pi\omega\rho}\right)^{\frac{1}{2}} [Ae^{i(kct - \omega\rho - \frac{1}{2}\pi - iz)} + Be^{i(kct - \omega\rho - \frac{1}{2}\pi - iz)}]$$

Thus the solution

$$\psi_0(\rho, z, t) = H_0^{(1)}(\omega\rho) e^{ikct - iz} \quad (26)$$

represents waves diverging from the axis $\rho = 0$, while the solution

$$\psi_1(\rho, z, t) = H_0^{(2)}(\omega\rho) e^{ikct - iz} \quad (27)$$

represents waves converging to this axis.

In the two-dimensional case ($\partial/\partial z = 0$) it follows from equation (16) of Sec. 4 that the analogue of equation (23) is

$$\psi(\rho, \phi, t) = [A_m H_m^{(1)}(k\rho) + B_m H_m^{(2)}(k\rho)] e^{ikct + im\phi} \quad (28)$$

while those of equations (26) and (27) are

$$\psi_0(\rho, t) = H_0^{(1)}(k\rho) e^{ikct} \quad (29)$$

and

$$\psi_1(\rho, t) = H_0^{(2)}(k\rho) e^{ikct} \quad (30)$$

respectively. The functions (29) and (30) play the same role in the theory of cylindrical waves as do the solutions (10) in the theory of spherical waves.

¹ I. N. Sneddon, "The Special Functions of Physics and Chemistry" (Oliver & Boyd, Edinburgh, 1956), p. 105.

PROBLEMS

1. A wave of frequency ν is propagated inside an endless uniform tube whose cross section is rectangular. (a) Calculate the phase velocity and the wavelength along the direction of propagation. (b) Show that if a wave is to be propagated along the tube, its frequency cannot be lower than

$$\nu_{\min} = \frac{c}{2} \left(\frac{1}{a^2} + \frac{1}{b^2} \right)^{\frac{1}{2}}$$

where a and b are the lengths of the sides of the cross section. (c) Verify that the group velocity is always less than c . Show that the group velocity tends to zero as the frequency decreases to ν_{\min} .

2. Show that the flux of energy through unit area of a fixed surface produced by sound waves of velocity potential ψ in a medium of average density ρ is

$$-\rho \frac{\partial \psi}{\partial t} \frac{\partial \psi}{\partial n}$$

A source of strength $A \cos(\sigma t)$ is situated at the origin. Show that the average rate at which the source loses energy to the air is

$$\frac{\rho A^2 \sigma^2}{8\pi c}$$

where c is the velocity of sound in air.

3. A symmetrical pressure disturbance $\rho_0 A \sin kct$ is maintained over the surface of a sphere of radius a which contains a gas of mean density ρ_0 . Find the velocity potential of the forced oscillation of the gas, and show that the radial velocity at any point of the surface of the sphere varies harmonically with amplitude

$$\frac{A}{c} \left(\frac{1}{ka} - \cot ka \right)$$

4. Air is contained between concentric spheres, the outer being of fixed radius b and the inner of oscillating radius $a(1 + \epsilon \sin kct)$, where ϵ is small. Prove that the velocity potential of the forced oscillations of the air is

$$\frac{\epsilon a^3 k c \cos \alpha}{\sin(kb - \beta + ka - \alpha)} \frac{\sin(kb - \beta + kr)}{r} \cos kct$$

where α and β are the acute angles defined by $\tan \alpha = ka$ and $\tan \beta = kb$.

5. A rigid spherical envelope of radius a containing air executes small oscillations so that its center is at any instant at the point $r = b \sin nt$, $\theta = 0$. Prove that the velocity potential of the air inside the sphere is

$$C \left(\frac{\cos kr}{kr} - \frac{\sin kr}{k^2 r^2} \right) \cos \theta \cos nt$$

where

$$C = \frac{nk^2 a^3 b}{2ka \cos ka - (2 - k^2 a^2) \sin ka}$$

6. Show that the wave equation has solutions of the form

$$\psi = S(\theta, \phi) R(r, t)$$

where θ, ϕ, r are spherical polar coordinates, l is a constant integer, and

$$\left\{ \frac{1}{\sin \theta} \left(\frac{\partial}{\partial \theta} \sin \theta \frac{\partial}{\partial \theta} \right) + \frac{1}{\sin^2 \theta} \frac{\partial^2}{\partial \phi^2} - l(l+1) \right\} S = 0$$

$$\left\{ \frac{1}{r^2} \frac{\partial}{\partial r} r^2 \frac{\partial}{\partial r} - \frac{l(l+1)}{r^2} - \frac{1}{c^2} \frac{\partial^2}{\partial t^2} \right\} R = 0$$

Verify that the last equation is satisfied by

$$R(r, t) = r^l \left(\frac{\partial}{r \partial r} \right)^l \frac{f(r - ct) + g(r + ct)}{r}$$

where f and g are arbitrary functions.

6. General Solutions of the Wave Equation

In this section we shall derive general solutions of the wave equation associated with the names of Helmholtz, Kirchhoff, and Poisson. The solutions of Helmholtz and Kirchhoff deal with wave problems in which the values of the wave function $\psi(r, t)$ and its normal derivative $\partial\psi/\partial n$ are prescribed on a surface S . From Kirchhoff's form of solutions of this problem we deduce Poisson's solution to the initial value problem in which ψ and $\partial\psi/\partial t$ are prescribed at time $t = 0$.

Suppose that Ψ is a solution of the space form of the wave equation

$$\nabla^2 \Psi + k^2 \Psi = 0 \quad (1)$$

and that the singularities of Ψ all lie outside a closed surface S bounding the volume V . Then putting

$$\Psi' = \frac{e^{ik|\mathbf{r}-\mathbf{r}'|}}{|\mathbf{r}-\mathbf{r}'|} \quad (2)$$

and this value of Ψ in Green's theorem in the form of equation (1) of Sec. 8 of Chap. 4, we find that if the point with position vector \mathbf{r} lies outside S , then

$$\int_S \left\{ \Psi(\mathbf{r}') \frac{\partial}{\partial n} \frac{e^{ik|\mathbf{r}-\mathbf{r}'|}}{|\mathbf{r}-\mathbf{r}'|} - \frac{e^{ik|\mathbf{r}-\mathbf{r}'|}}{|\mathbf{r}-\mathbf{r}'|} \frac{\partial \Psi(\mathbf{r}')}{\partial n} \right\} dS' = 0 \quad (3)$$

On the other hand, if P lies inside S , by applying Green's theorem to the region bounded externally by S and internally by C , a small sphere with center \mathbf{r} and radius ϵ (cf. Fig. 23), we find that

$$\int_S \left\{ \Psi(\mathbf{r}') \frac{\partial}{\partial n} \frac{e^{ik|\mathbf{r}-\mathbf{r}'|}}{|\mathbf{r}-\mathbf{r}'|} - \frac{e^{ik|\mathbf{r}-\mathbf{r}'|}}{|\mathbf{r}-\mathbf{r}'|} \frac{\partial \Psi(\mathbf{r}')}{\partial n} \right\} dS'$$

$$= \lim_{\epsilon \rightarrow 0} \int_C \left\{ \left(ik - \frac{1}{|\mathbf{r}-\mathbf{r}'|} \right) \Psi(\mathbf{r}') - \frac{\partial \Psi(\mathbf{r}')}{\partial r'} \right\} \frac{e^{ik|\mathbf{r}-\mathbf{r}'|}}{|\mathbf{r}-\mathbf{r}'|} dS'$$

and by a process similar to that employed in Sec. 8 of Chap. 4 we can

show that the value of the limit on the right-hand side of this equation is $-4\pi\psi(\mathbf{r})$.

Hence we have:

Helmholtz's First Theorem. *If $\psi(\mathbf{r})$ is a solution of the space form of the wave equation $\nabla^2\psi = -k^2\psi = 0$ whose partial derivatives of the first and second orders are continuous within the volume V on the closed surface S bounding V , then*

$$\frac{1}{4\pi} \int_S \left\{ \frac{e^{ik|\mathbf{r}-\mathbf{r}'|}}{|\mathbf{r}-\mathbf{r}'|} \frac{\partial\psi(\mathbf{r}')}{\partial n} - \psi(\mathbf{r}') \frac{\partial}{\partial n} \left(\frac{e^{ik|\mathbf{r}-\mathbf{r}'|}}{|\mathbf{r}-\mathbf{r}'|} \right) \right\} dS' = \begin{cases} \psi(\mathbf{r}) & \text{if } \mathbf{r} \in V \\ 0 & \text{if } \mathbf{r} \notin V \end{cases} \quad (4)$$

where \mathbf{n} is the outward normal to S .

Helmholtz's first theorem is applicable in the case when all the singularities of the function $\psi(\mathbf{r})$ lie outside a certain volume V . We now consider the case in which all the singularities of ψ lie within a closed surface S . If we now apply Green's theorem to the region V bounded internally by S and externally by Σ , a sphere of center the origin and very large radius R , we find, on letting $R \rightarrow \infty$:

Helmholtz's Second Theorem. *If $\psi(\mathbf{r})$ is a solution of the space form of the wave equation whose partial derivatives of the first and second orders are continuous outside the volume V and on the closed surface S bounding V , if $r\psi(\mathbf{r})$ is bounded, and if*

$$r \left(\frac{\partial\psi}{\partial r} - ik\psi \right) \rightarrow 0$$

uniformly with respect to the angle variables as $r \rightarrow \infty$, then

$$\frac{1}{4\pi} \int_S \left\{ \psi(\mathbf{r}') \frac{\partial}{\partial n} \left(\frac{e^{ik|\mathbf{r}-\mathbf{r}'|}}{|\mathbf{r}-\mathbf{r}'|} \right) - \frac{\partial\psi(\mathbf{r}')}{\partial n} \frac{e^{ik|\mathbf{r}-\mathbf{r}'|}}{|\mathbf{r}-\mathbf{r}'|} \right\} dS' = \begin{cases} \psi(\mathbf{r}) & \text{if } \mathbf{r} \notin V \\ 0 & \text{if } \mathbf{r} \in V \end{cases} \quad (5)$$

where \mathbf{n} is the outward normal to S .

It would appear from Helmholtz's formulas that the values taken by ψ and $\partial\psi/\partial n$ on the surface S can be assigned arbitrarily and independently of each other. By use of a Green's function $G(\mathbf{r},\mathbf{r}')$ with singularity at P (see Sec. 7 below) we can express $\psi(\mathbf{r})$ in terms of $\psi(\mathbf{r}')$ alone through the equation

$$\psi(\mathbf{r}) = -\frac{1}{4\pi} \int_S \psi(\mathbf{r}') \frac{\partial G}{\partial n} dS'$$

so that knowing the value of ψ on the surface S , we can, in general, determine $\psi(\mathbf{r})$ uniquely and, in particular, calculate the value of $\partial\psi/\partial n$ on S . It can also be shown that if $\partial\psi/\partial n$ is prescribed on S , $\psi(\mathbf{r})$ is in general determined uniquely so that its value on S can be

determined. The values of Ψ' and $\partial\Psi'/\partial n$ on S are therefore related. If the functions $f(\mathbf{r})$ and $g(\mathbf{r})$ are defined in an arbitrary way, then the function

$$\Psi(\mathbf{r}) = \frac{1}{4\pi} \int_S \left(f(\mathbf{r}') \frac{e^{ik|\mathbf{r}-\mathbf{r}'|}}{|\mathbf{r}-\mathbf{r}'|} - g(\mathbf{r}') \frac{\partial}{\partial n} \frac{e^{ik|\mathbf{r}-\mathbf{r}'|}}{|\mathbf{r}-\mathbf{r}'|} \right) dS'$$

satisfies the space form of the wave equation, but it does not necessarily follow that $\Psi(\mathbf{r}') = g(\mathbf{r}')$, $\partial\Psi'/\partial n = f(\mathbf{r}')$ on S .

Similarly in the two-dimensional case by taking

$$\Psi'' = H_0^{(1)}(k|\boldsymbol{\rho} - \boldsymbol{\rho}'|)$$

where $\boldsymbol{\rho} = (x,y)$, in the two-dimensional form of Green's theorem, we can readily establish the two-dimensional analogue of Helmholtz's first theorem:

Weber's Theorem. *If $\Psi(\boldsymbol{\rho})$ is a solution of the space form of the two-dimensional wave equation $\nabla_{\perp}^2\Psi - k^2\Psi = 0$ whose partial derivatives of the first and second orders are continuous within the area S and on the closed curve Γ bounding S , then*

$$\begin{aligned} \frac{1}{4i} \int_{\Gamma} \left\{ \Psi(\boldsymbol{\rho}') \frac{\partial}{\partial n} H_0^{(1)}(k|\boldsymbol{\rho} - \boldsymbol{\rho}'|) - H_0^{(1)}(k|\boldsymbol{\rho} - \boldsymbol{\rho}'|) \frac{\partial \Psi(\boldsymbol{\rho}')}{\partial n} \right\} ds' \\ = \begin{cases} \Psi(\boldsymbol{\rho}) & \text{if } \boldsymbol{\rho} \in S \\ 0 & \text{if } \boldsymbol{\rho} \notin S \end{cases} \end{aligned}$$

where \mathbf{n} is the outward normal to Γ . The proof is left as an exercise to the reader.¹

Helmholtz's first theorem can be expressed in another way by introducing the idea of a retarded value. If $\psi(\mathbf{r}',t)$ is a function of the coordinates of a variable point with position vector \mathbf{r}' , then we define the retarded value $[\psi]$ of ψ by the equation

$$[\psi] = \psi \left(\mathbf{r}', t - \frac{\lambda}{c} \right), \quad \lambda = |\mathbf{r}' - \mathbf{r}| \tag{6}$$

where \mathbf{r} is the position vector of some fixed point. If

$$\psi(\mathbf{r}',t) = \Psi(\mathbf{r}')e^{-ikct}$$

then it is obvious that

$$[\psi] = \psi(\mathbf{r}',t)e^{-ik\lambda}, \quad \left[\frac{\partial \psi}{\partial t} \right] = -ikc[\psi] \tag{7}$$

If, now, we multiply both sides of the equation which occurs in Helmholtz's first theorem by e^{ikct} , we find that if the point with position

¹ See Weber, *Math. Ann.*, **1**, 1(1869), and B. B. Baker and E. T. Copson, "The Mathematical Theory of Huygens' Principle," 2d ed. (Oxford, London, 1950), pp. 50-51.

vector \mathbf{r} is inside the surface S , then that equation can be written in the form

$$\psi(\mathbf{r}, t) = \frac{1}{4\pi} \int_S \left\{ [\psi] \frac{\partial \lambda}{\partial n} \left(\frac{1}{\lambda} \right) - \frac{d}{d\lambda} \left(\frac{1}{\lambda} \right) - \frac{1}{\lambda} \left[\frac{\partial \psi}{\partial n} \right] \right\} dS'$$

which, because of the second of equations (6), can be written in the form

$$\psi(\mathbf{r}, t) = \frac{1}{4\pi} \int_S \left\{ -[\psi] \frac{\partial}{\partial n} \left(\frac{1}{\lambda} \right) + \frac{1}{c\lambda} \frac{\partial \lambda}{\partial n} \left[\frac{\partial \psi}{\partial t} \right] + \frac{1}{\lambda} \left[\frac{\partial \psi}{\partial n} \right] \right\} dS' \quad (8)$$

Now an arbitrary wave function $\psi(\mathbf{r}, t)$ can be expressed, either by a Fourier series or by a Fourier integral, as a linear combination of wave functions of the type $\Psi_k(\mathbf{r})e^{ikct}$, and since the equation (8) does not contain k explicitly, it follows that it is true for any wave function. It can also be shown that if the point with position vector \mathbf{r} lies outside S , the right-hand side of equation (8) is equal to zero. We therefore have:

Kirchhoff's First Theorem. *If $\psi(\mathbf{r}, t)$ is a solution of the wave equation whose partial derivatives of the first and second orders are continuous within the volume V and on the surface S bounding V , then*

$$\begin{aligned} \frac{1}{4\pi} \int_S \left\{ -[\psi] \frac{\partial}{\partial n} \left(\frac{1}{\lambda} \right) + \frac{1}{c\lambda} \frac{\partial \lambda}{\partial n} \left[\frac{\partial \psi}{\partial t} \right] + \frac{1}{\lambda} \left[\frac{\partial \psi}{\partial n} \right] \right\} dS' \\ = \begin{cases} \psi(\mathbf{r}, t) & \text{if } P(\mathbf{r}) \in V \\ 0 & \text{if } P(\mathbf{r}) \notin V \end{cases} \quad (9) \end{aligned}$$

where $\lambda = |\mathbf{r} - \mathbf{r}'|$ and \mathbf{n} is the outward normal to S .

For a direct proof of Kirchhoff's first theorem the reader is referred to pages 38 to 40 of "The Mathematical Theory of Huygens' Principle," by Baker and Copson. In the case where the singularities of $\psi(\mathbf{r}, t)$ all lie outside a given closed surface we have:

Kirchhoff's Second Theorem. *If $\psi(\mathbf{r}, t)$ is a solution of the wave equation which has no singularities outside the region V bounded by the surface S for all values of the time from $-\infty$ to t , and if as $r \rightarrow \infty$,*

$$\psi(\mathbf{r}, t) \sim \frac{f(ct - r)}{r} .$$

where $f(u), f'(u)$ are bounded near $u = -\infty$, then

$$\frac{1}{4\pi} \int_S \left\{ [\psi] \frac{\partial}{\partial n} \left(\frac{1}{\lambda} \right) - \frac{1}{c\lambda} \frac{\partial \lambda}{\partial n} \left[\frac{\partial \psi}{\partial t} \right] - \frac{1}{\lambda} \left[\frac{\partial \psi}{\partial n} \right] \right\} dS' = \begin{cases} \psi(\mathbf{r}) & \text{if } P(\mathbf{r}) \in V \\ 0 & \text{if } P(\mathbf{r}) \notin V \end{cases} \quad (10)$$

where \mathbf{n} is the outward normal to S .

We get a special form of these results if we take the surface S to be the sphere with equation

$$\lambda \equiv |\mathbf{r}' - \mathbf{r}| = ct \quad (11)$$

Then at any point of S

$$[\psi] = \psi(\mathbf{r}', 0) = f(\mathbf{r}')$$

where f is the value of ψ at $t = 0$. Similarly

$$\left[\frac{\partial \psi}{\partial t} \right]_0 = \frac{\partial \psi(\mathbf{r}', 0)}{\partial t} = g(\mathbf{r}')$$

where g is the value of $\partial \psi / \partial t$ at $t = 0$. If we substitute this result in equation (9), we find that

$$\psi(\mathbf{r}, t) = \frac{1}{4\pi} \int_S \left\{ \frac{f}{\lambda^2} \div \frac{g}{c\lambda} \div \frac{1}{\lambda} \left(\frac{\partial f}{\partial \lambda} \right)_0 \right\} dS' \quad (12)$$

where S has the equation (11). Now if we denote by the symbol $M_r(f)$ the mean value of the function f over the sphere (11), then

$$\frac{1}{4\pi} \int_S \frac{g dS'}{c\lambda} = tM_r(g)$$

and

$$\frac{1}{4\pi} \int_S \left(\frac{f}{\lambda^2} + \frac{1}{\lambda} \frac{\partial f}{\partial \lambda} \right) dS' = \frac{\partial}{\partial t} [tM_r(f)]$$

Substituting these expressions in equation (12), we find that

$$\psi(\mathbf{r}, t) = \frac{\partial}{\partial t} [tM_r(f)] \div tM_r(g) \quad (13)$$

is the solution of the wave equation which satisfies the initial conditions

$$\psi = f, \quad \frac{\partial \psi}{\partial t} = g, \quad t = 0 \quad (14)$$

The solution (12) is *Poincaré's solution* of the initial value problem (14). Equation (13) expresses *Poisson's solution*. For a direct proof of Poisson's solution see Prob. 2 below.

PROBLEMS

1. If $\psi(\rho, t) = \Psi(\rho)e^{-i\omega t}$ is a two-dimensional function in which $\Psi(\rho)$ does not depend on t , prove that

$$\psi(\rho, t) = \frac{1}{2\pi} \int_{\Gamma} \left\{ \left[\frac{\partial \Psi(\rho')}{\partial n} - \Psi(\rho') \frac{\partial}{\partial n} \right] \int_{\rho_1}^{\infty} \frac{e^{i\omega(u-t)}}{\sqrt{u^2 - \rho_1^2}} du \right\} dS'$$

if ρ lies within the closed contour Γ , where $\rho_1 = |\rho - \rho'|$.

Show that if we write

$$\frac{\partial f}{\partial n} = \frac{\partial f}{\partial x} \frac{\partial x}{\partial n} \div \frac{\partial f}{\partial y} \frac{\partial y}{\partial n}, \quad \frac{\delta f}{\delta n} = \frac{\partial f}{\partial \rho_1} \frac{\partial \rho_1}{\partial n}$$

this result becomes

$$\psi(\rho, t) = \frac{1}{2\pi} \int_{\Gamma} \left\{ \left(\frac{\partial}{\partial n} - \frac{\delta}{\delta n} \right) \int_{\rho_1}^{\infty} \frac{\psi(\rho, t - u/c) du \right\} dS'$$

2. Using the principle of superposition, show that if g and F are arbitrary,

$$\psi(\mathbf{r}, t) = -\frac{1}{4\pi c^2} \int_V \frac{g(\mathbf{r}')}{|\mathbf{r} - \mathbf{r}'|} F\left(t - \frac{|\mathbf{r} - \mathbf{r}'|}{c}\right) d\tau'$$

is a solution of the wave equation provided \mathbf{r} is not the position vector of a point of V .

Taking $F(u)$ to be e^{-1} when $- \epsilon \leq u \leq 0$ and zero otherwise, prove that

$$\psi(\mathbf{r}, t) = tM_r(g)$$

and deduce that when $t = 0$,

$$\psi = 0, \quad \frac{\partial \psi}{\partial t} = g$$

3. The function $\psi(\mathbf{r}, t)$ satisfies the wave equation. If at time $t = 0$, $\psi = 0$ for all r and

$$\frac{\partial \psi}{\partial t} = \begin{cases} k & 0 < r < a \\ 0 & r > a \end{cases}$$

where k is a constant, use Poisson's solution to determine the values of ψ and $\partial\psi/\partial t$ at any subsequent time.

Determine the solution also by making use of equation (13) of Sec. 5.

7. Green's Function for the Wave Equation

In this section we shall show how the solution of the space form of the wave equation under certain boundary conditions can be made to depend on the determination of the appropriate Green's function.

Suppose that $G(\mathbf{r}, \mathbf{r}')$ satisfies the equation

$$\left(\frac{\partial^2}{\partial x'^2} + \frac{\partial^2}{\partial y'^2} + \frac{\partial^2}{\partial z'^2} \right) G(\mathbf{r}, \mathbf{r}') + k^2 G(\mathbf{r}, \mathbf{r}') = 0 \quad (1)$$

and that it is finite and continuous with respect to either the variables x, y, z or to the variables x', y', z' for points \mathbf{r}, \mathbf{r}' belonging to a region V which is bounded by a closed surface S except in the neighborhood of the point \mathbf{r} , where it has a singularity of the same type as

$$\frac{e^{ik|\mathbf{r}-\mathbf{r}'|}}{|\mathbf{r}-\mathbf{r}'|} \quad (2)$$

as $\mathbf{r}' \rightarrow \mathbf{r}$. Then proceeding as in the derivation of equation (4) of the last section, we can prove that, if \mathbf{r} is the position vector of a point within V , then

$$\Psi(\mathbf{r}) = \frac{1}{4\pi} \int_S \left(G(\mathbf{r}, \mathbf{r}') \frac{\partial \Psi(\mathbf{r}')}{\partial n} - \Psi(\mathbf{r}') \frac{\partial G(\mathbf{r}, \mathbf{r}')}{\partial n} \right) dS' \quad (3)$$

where \mathbf{n} is the outward-drawn normal to the surface S .

It follows immediately from equation (3) that if $G_1(\mathbf{r}, \mathbf{r}')$ is such a function and if it satisfies the boundary condition

$$G_1(\mathbf{r}, \mathbf{r}') = 0 \quad (4)$$

if the point with position vector \mathbf{r}' lies on S , then

$$\Psi(\mathbf{r}) = -\frac{1}{4\pi} \int_S \Psi(\mathbf{r}') \frac{\partial G_1(\mathbf{r}, \mathbf{r}')}{\partial n} dS' \tag{5}$$

by means of which the value of Ψ at any point \mathbf{r} within S can be calculated in terms of the values of Ψ on the boundary.

Similarly if $G_2(\mathbf{r}, \mathbf{r}')$ is a function of this kind satisfying the boundary condition

$$\frac{\partial G_2}{\partial n} = 0 \quad \text{for } \mathbf{r}' \in S \tag{6}$$

then we obtain

$$\Psi(\mathbf{r}) = \frac{1}{4\pi} \int_S \frac{\partial \Psi(\mathbf{r}')}{\partial n} G_2(\mathbf{r}, \mathbf{r}') dS' \tag{7}$$

a formula which enables us to calculate Ψ at any point within S when the value of $\partial \Psi / \partial n$ is known at every point of S .

Similar results can be obtained in the case of a more general boundary condition (cf. Prob. 1 below) and in the two-dimensional case (cf. Prob. 2 below).

We shall consider the special cases in which the surface S is a plane:

Green's Functions for the Half Space $z \geq 0$. It is obvious that in this instance

$$G_1(\mathbf{r}, \mathbf{r}') = \frac{e^{ik|\mathbf{r}-\mathbf{r}'|}}{|\mathbf{r}-\mathbf{r}'|} - \frac{e^{ik|\boldsymbol{\rho}-\mathbf{r}'|}}{|\boldsymbol{\rho}-\mathbf{r}'|} \tag{8}$$

where $\boldsymbol{\rho} = (x, y, -z)$ is the position vector of the image in the plane $z = 0$ of the point with position vector $\mathbf{r} = (x, y, z)$. For this function it is easily shown that if the point with position vector \mathbf{r}' lies on Π , the xy plane, then

$$\frac{\partial G_1}{\partial n} = -\frac{\partial G_1}{\partial z'} = 2 \frac{\partial}{\partial z} \left(\frac{e^{ikR}}{R} \right)$$

where $R^2 = (x - x')^2 + (y - y')^2 + z^2$. It follows from equation (5) that if $\Psi = f(x, y)$ on $z = 0$, then when $z > 0$,

$$\Psi(x, y, z) = -\frac{1}{2\pi} \frac{\partial}{\partial z} \int_{\Pi} f(x', y') \frac{e^{ikR}}{R} dx' dy' \tag{9}$$

Similarly it can be shown that

$$G_2(\mathbf{r}, \mathbf{r}') = \frac{e^{ik|\mathbf{r}-\mathbf{r}'|}}{|\mathbf{r}-\mathbf{r}'|} + \frac{e^{ik|\boldsymbol{\rho}-\mathbf{r}'|}}{|\boldsymbol{\rho}-\mathbf{r}'|} \tag{10}$$

so that on the plane Π

$$G_2(\mathbf{r}, \mathbf{r}') = \frac{2e^{ikR}}{R}$$

It follows from equation (7) that if $\partial\psi/\partial z = g(x,y)$ on the plane Π , then when $z > 0$,

$$\psi(x,y,z) = \frac{1}{2\pi} \int_{\Pi} g(x',y') \frac{e^{ikR}}{R} dx' dy' \tag{11}$$

We shall now indicate how the solution (11) may be applied in the theory of diffraction of "monochromatic" sound waves by an infinite plane screen which is assumed to be perfectly reflecting but which contains holes of arbitrary size and shape. We shall assume that the screen lies in the xy plane, and, for convenience, we shall denote the holes in the screen by S_1 and the material screen itself by S_2 . If we assume that monochromatic waves which in the absence of the screen have velocity potential $\psi_i(\mathbf{r})e^{ikct}$ are incident on the positive side of the

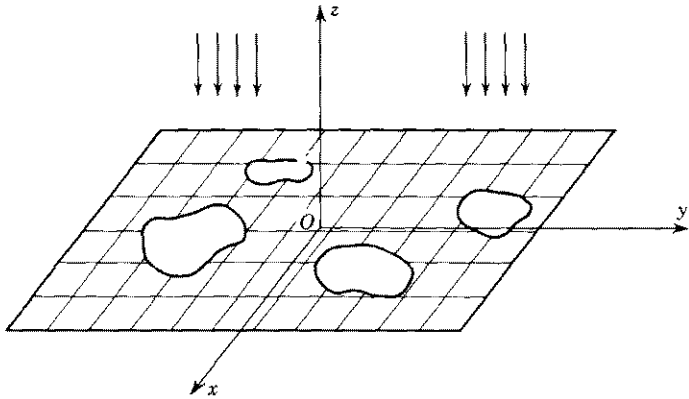

Figure 42

screen (cf. Fig. 42), then the reflected and diffracted wave produced by the screen will have a velocity potential of the form $\psi'_s(\mathbf{r})e^{ikct}$, and the total velocity potential of the sound waves will be $\psi(\mathbf{r})e^{ikct}$, where

$$\psi(\mathbf{r}) = \psi_i(\mathbf{r}) + \psi'_s(\mathbf{r}) \tag{12}$$

The boundary conditions of the problem are that, on the material of the screen, the normal component of the velocity of the gas must vanish, i.e., that

$$\frac{\partial\psi'_s}{\partial z} = -\frac{\partial\psi_i}{\partial z} \quad \text{on } S_2 \tag{13}$$

and that, in each aperture, the total velocity potential must be equal to the incident velocity potential, i.e., that

$$\psi'_s = 0 \quad \text{on } S_1 \tag{14}$$

To solve this problem we suppose that on S_1

$$\left(\frac{\partial\psi}{\partial z}\right)_{z=0} = \left(\frac{\partial\psi'_s}{\partial z} + \frac{\partial\psi_i}{\partial z}\right)_{z=0} = f(x,y) \tag{15}$$

If we substitute the value for $(\partial\Psi_S/\partial z)_{z=0}$ obtained from equation (15) into equation (11), we find that

$$\Psi_S(\mathbf{r}) = \frac{1}{2\pi} \int_{\Pi} \left(\frac{\partial\Psi_i}{\partial z'} \right)_{z'=0} \frac{e^{-ikR}}{R} dx' dy' - \frac{1}{2\pi} \int_{S_1} f(x', y') \frac{e^{-ikR}}{R} dx' dy' \quad (16)$$

Now if we put $f(x', y') \equiv 0$ in equation (16), we get the solution appropriate to the problem in which the screen has no holes and this must yield the velocity potential of the waves reflected by an unperforated screen occupying the entire xy plane. It is readily shown that if $z > 0$, this velocity potential has the space form $\Psi_i(\boldsymbol{\rho})$, where $\boldsymbol{\rho} = (x, y, -z)$ is the position vector of the image in the plane $z = 0$ of the point with position vector $\mathbf{r} = (x, y, z)$. Hence if $z > 0$, we must have

$$\Psi(\mathbf{r}) = \Psi_i(\mathbf{r}) + \Psi_i(\boldsymbol{\rho}) - \frac{1}{2\pi} \int_{S_1} f(x', y') \frac{e^{-ikR}}{R} dx' dy' \quad (17)$$

We have still to ensure that the condition (14) is satisfied. To achieve this we must choose $f(x, y)$ so that when $(x, y, 0)$ belongs to S_1

$$\int_{S_1} f(x', y') \frac{e^{-ik\lambda}}{\lambda} dx' dy' = 2\pi\Psi_i(x, y, 0) \quad (18)$$

where $\lambda = +\sqrt{(x-x')^2 + (y-y')^2}$.

Hence when $z > 0$, the solution of our diffraction problem is given by equation (17), where the function $f(x, y)$ satisfies the integral equation (18).

We can deduce the solution in the case $z < 0$ very easily. If we superimpose the solution of the problem in which waves with velocity potential $\Psi_i(\boldsymbol{\rho})e^{ikct}$ are incident on the negative side of the screen, we find that the resulting solution $[\Psi_i(\mathbf{r}) + \Psi_i(\boldsymbol{\rho})]e^{ikct}$ automatically satisfies the boundary conditions (13) and (14). Hence we have the relation

$$\Psi(\mathbf{r}) + \Psi(\boldsymbol{\rho}) = \Psi_i(\mathbf{r}) + \Psi_i(\boldsymbol{\rho})$$

from which it follows that if $z < 0$,

$$\Psi(\mathbf{r}) = \frac{1}{2\pi} \int_{S_1} f(x', y') \frac{e^{-ikR}}{R} dx' dy' \quad (19)$$

where $f(x, y)$ again satisfies the integral equation (18).

PROBLEMS

1. The function $G_S(\mathbf{r}, \mathbf{r}')$ satisfies $(\nabla^2 - k^2)G = 0$ and is finite and continuous with respect to x, y, z or x', y', z' in the region V bounded by the closed surface S except in the neighborhood of the point \mathbf{r} , where it has a singularity of the form $\text{except in the neighborhood of the point } \mathbf{r}$, where it has a singularity of the same

type as $e^{ik|\mathbf{r}-\mathbf{r}'|}/|\mathbf{r}-\mathbf{r}'|$ as $\mathbf{r} \rightarrow \mathbf{r}'$. It also satisfies the condition that $\partial G_3/\partial n = hG_3$ vanishes on S , h being a constant.

If $\Psi(\mathbf{r})e^{ikct}$ is a wave function satisfying the condition

$$\frac{\partial \Psi}{\partial n} = h\Psi - f$$

for points on S , show that

$$\Psi(\mathbf{r}) = \frac{1}{4\pi} \int_S f(\mathbf{r}') G_2(\mathbf{r}, \mathbf{r}') dS'$$

2. If $G_1(\rho, \rho')$ is such that

$$\left(\frac{\partial^2}{\partial x'^2} - \frac{\partial^2}{\partial y'^2} - k^2 \right) G_1 = 0$$

with $\rho = (x, y)$, $\rho' = (x', y')$ and is finite and continuous in the plane region S bounded by the curve Γ except that it has a singularity of type $H_0^{(1)}(k|\rho - \rho'|)$ as $\rho' \rightarrow \rho$, and if $G_1 = 0$ on Γ , prove that

$$\Psi(\rho) = \frac{1}{4i} \int_{\Gamma} \Psi(\rho') \frac{\partial G_1}{\partial n} dS$$

If $G_2(\rho, \rho')$ obeys the same conditions as $G_1(\rho, \rho')$ except that $\partial G_2/\partial n = 0$ and $G_2 \neq 0$ on Γ , prove that

$$\Psi(\rho) = -\frac{1}{4i} \int_{\Gamma} \frac{\partial \Psi(\rho')}{\partial n} G_2(\rho, \rho') ds$$

3. Monochromatic sound waves of velocity potential $\Psi'(\mathbf{r})e^{ikt}$ are incident on the positive side of a perfectly conducting screen in the xy plane which has a small aperture S_1 at the point $(0,0,0)$. The dimensions of the aperture are small in comparison with the wavelength $2\pi/k$ of the incident wave. Show that at a great distance \mathbf{r} from the aperture on the negative side of the screen the velocity potential is given approximately by

$$\Psi'(\mathbf{r}, t) = \frac{Ae^{-ik(x-ct)}}{r}$$

where

$$A = \frac{1}{2\pi} \int_{S_1} f(x, y) dx dy$$

and

$$\int_{S_1} \frac{f(x', y') dx' dy'}{\sqrt{(x-x')^2 + (y-y')^2}} = 2\pi\Psi'(0,0,0)$$

Deduce that $A = C\Psi'(0,0,0)$ where C is the capacity of a conducting disk which has the size and shape of the aperture S_1 .

4. Monochromatic waves of velocity potential $\Psi'(\mathbf{r})e^{ikt}$ are incident on the positive side of an infinite perforated screen occupying the plane $z = 0$ of such material that the total velocity potential vanishes on the screen. Show that the velocity potential $\Psi'(\mathbf{r})e^{ikt}$ is given everywhere by

$$\Psi'(\mathbf{r}) = \Psi'_0(\mathbf{r}) - \frac{1}{2\pi} \int_{S_2} f(x', y') \frac{e^{-ikR}}{R} dx' dy'$$

where $R = \sqrt{(x-x')^2 + (y-y')^2 + z^2}$ and $f(x, y)$ satisfies the integral equation

$$\int_{S_2} f(x', y') \frac{e^{-ik\lambda}}{\lambda} dx' dy' = 2\pi\Psi'_0(x, y, 0)$$

when $(x, y, 0)$ is a point of S_2 , the screen itself, and $\lambda = \sqrt{(x-x')^2 + (y-y')^2}$.

8. The Nonhomogeneous Wave Equation

The second-order hyperbolic equation

$$L\psi = f(\mathbf{r}, t) \quad (1)$$

where

$$L = \frac{1}{c^2} \frac{\partial^2}{\partial t^2} - \nabla^2 \quad (2)$$

which arises in electromagnetic theory and other branches of mathematical physics is called the *nonhomogeneous wave equation*. It is readily seen that if ψ_1 is any solution of the nonhomogeneous equation (1) and ψ_2 is any solution of the wave equation, then

$$\psi = \psi_1 - \psi_2 \quad (3)$$

is also a solution of equation (1).

Suppose that a function ψ satisfies equation (1) in the finite region bounded by a closed surface S and that we wish to find the value of the function at a point P , with position vector \mathbf{r} , which lies within S . If we denote by Ω the region bounded by S and the sphere C of center P and small radius ϵ , we may write Green's theorem in the form

$$\int_{\Omega} (\psi \nabla^2 \phi - \phi \nabla^2 \psi) d\tau' = \left(\int_C + \int_S \right) \left(\psi \frac{\partial \phi}{\partial n} - \phi \frac{\partial \psi}{\partial n} \right) dS' \quad (4)$$

where the normals \mathbf{n} are in the directions shown in Fig. 23. In equation (4) we take $\psi(\mathbf{r}')$ to be a solution of equation (1), so that

$$\nabla^2 \psi(\mathbf{r}') = \frac{1}{c^2} \frac{\partial^2}{\partial t'^2} \psi(\mathbf{r}') - f(\mathbf{r}', t) \quad (5)$$

and assume that

$$\phi = \frac{1}{|\mathbf{r} - \mathbf{r}'|} F\left(t - t' + \frac{|\mathbf{r} - \mathbf{r}'|}{c}\right) \quad (6)$$

where t' is a constant and the function F is arbitrary. It follows that $L\phi = 0$, so that

$$\nabla^2 \phi = \frac{1}{c^2} \frac{\partial^2 \phi}{\partial t'^2} \quad (7)$$

Substituting from equation (5) and (7) into equation (4), we find that

$$\begin{aligned} \frac{1}{c^2} \frac{\partial}{\partial t} \int_{\Omega} \left(\psi \frac{\partial \phi}{\partial t} - \phi \frac{\partial \psi}{\partial t} \right) d\tau' &= \int_{\Omega} f(\mathbf{r}', t) \phi d\tau' \\ &= \left(\int_C + \int_S \right) \left(\psi \frac{\partial \phi}{\partial n} - \phi \frac{\partial \psi}{\partial n} \right) dS' \end{aligned}$$

If we now integrate with respect to t from $-\infty$ to $+\infty$ and assume that

ψ , $\frac{\partial \psi}{\partial t}$ vanish for $t = \pm \infty$, we find, on interchanging the order of the integrations, that

$$\int_{\Omega} d\tau' \left(\int_{-\infty}^{\infty} f(\mathbf{r}', t) \phi dt \right) = \left(\int_{t'} + \int_{\Omega} \right) \left\{ \int_{-\infty}^{\infty} \left(\psi \frac{\partial \phi}{\partial n} - \phi \frac{\partial \psi}{\partial n} \right) dt \right\} dS' \quad (8)$$

It is readily shown that

$$\int_C \left\{ \int_{-\infty}^{\infty} \left(\psi \frac{\partial \phi}{\partial n} - \phi \frac{\partial \psi}{\partial n} \right) dt \right\} dS' = 4\pi \int_{-\infty}^{\infty} \psi(\mathbf{r}, t) F(t - t') dt + O(\varepsilon) \quad (9)$$

and that

$$\begin{aligned} & \int_S \left\{ \int_{-\infty}^{\infty} \phi \frac{\partial \psi}{\partial n} dt \right\} dS' \\ &= \int_S \frac{dS'}{|\mathbf{r} - \mathbf{r}'|} \left\{ \int_{-\infty}^{\infty} \frac{\partial \psi(\mathbf{r}', t)}{\partial n} F \left(t - t' + \frac{|\mathbf{r} - \mathbf{r}'|}{c} \right) dt \right\} \end{aligned} \quad (10)$$

and

$$\begin{aligned} & \int_S \left\{ \int_{-\infty}^{\infty} \psi \frac{\partial \phi}{\partial n} dt \right\} dS' \\ &= \int_S dS' \left\{ \int_{-\infty}^{\infty} \left[\psi(\mathbf{r}', t) \frac{\partial}{\partial n} \frac{1}{|\mathbf{r} - \mathbf{r}'|} - \frac{1}{c} \frac{\partial \psi(\mathbf{r}', t)}{\partial t} \cdot \frac{1}{|\mathbf{r} - \mathbf{r}'|} \right. \right. \\ & \quad \left. \left. \times \frac{\partial |\mathbf{r} - \mathbf{r}'|}{\partial n} \right] F \left(t - t' + \frac{|\mathbf{r} - \mathbf{r}'|}{c} \right) dt \right\} \end{aligned} \quad (11)$$

So far the function F has been arbitrary. Suppose we now assume that

$$F(x) = \begin{cases} \frac{1}{2\eta} & -\eta \leq x \leq \eta \\ 0 & \text{otherwise} \end{cases}$$

Then, using the mean value theorem of the integral calculus, we find that

$$\int_{-\infty}^{\infty} f(\mathbf{r}', t) \phi dt = \frac{1}{|\mathbf{r} - \mathbf{r}'|} f \left(\mathbf{r}', t' - \frac{|\mathbf{r} - \mathbf{r}'|}{c} + \theta_1 \eta \right) \quad -1 \leq \theta_1 \leq 1$$

so that

$$\int_{\Omega} d\tau' \left(\int_{-\infty}^{\infty} f(\mathbf{r}', t) \phi dt \right) = \int_{\Omega} f \left(\mathbf{r}', t' - \frac{|\mathbf{r} - \mathbf{r}'|}{c} + \theta_1 \eta \right) \frac{dS'}{|\mathbf{r} - \mathbf{r}'|} \quad (12)$$

Similarly, from (9) we have

$$\int_C \left\{ \int_{-\infty}^{\infty} \left(\psi \frac{\partial \phi}{\partial n} - \phi \frac{\partial \psi}{\partial n} \right) dt \right\} dS' = 4\pi \psi(\mathbf{r}, t' + \theta_2 \eta) \quad (13)$$

where $-1 \leq \theta_2 \leq 1$, and from equations (10) and (11) we have

$$\int_S \left\{ \int_{-\infty}^z \phi \frac{\partial \psi}{\partial n} dt \right\} dS' = \int_S \frac{dS'}{|\mathbf{r} - \mathbf{r}'|} \frac{\partial \psi \left(\mathbf{r}', t - \frac{|\mathbf{r} - \mathbf{r}'|}{c} + \theta_2 t \right)}{\partial n} \quad (14)$$

and

$$\begin{aligned} & \int_S \left\{ \int_{-\infty}^z \psi \frac{\partial \phi}{\partial n} dt \right\} dS' \\ &= \int_S dS' \left\{ \psi \left(\mathbf{r}', t - \frac{|\mathbf{r} - \mathbf{r}'|}{c} + \theta_3 t \right) \frac{\partial}{\partial n} \frac{1}{|\mathbf{r} - \mathbf{r}'|} \right. \\ & \quad \left. - \frac{1}{c} \frac{\partial}{\partial t} \psi \left(\mathbf{r}', t - \frac{|\mathbf{r} - \mathbf{r}'|}{c} + \theta_3 t \right) \frac{1}{|\mathbf{r} - \mathbf{r}'|} \frac{\partial |\mathbf{r} - \mathbf{r}'|}{\partial n} \right\} \quad (15) \end{aligned}$$

where $-1 \leq \theta_3, \theta_4 \leq 1$. Substituting from equations (12), (13), (14), and (15) into equation (8) and letting $\eta \rightarrow 0$, we find, on replacing t' by t , that

$$\begin{aligned} \psi(\mathbf{r}, t) &= \frac{1}{4\pi} \int_{\Omega} \frac{[f] d\tau'}{|\mathbf{r} - \mathbf{r}'|} \\ & \quad - \frac{1}{4\pi} \int_S \left\{ \left[\frac{\partial \psi}{\partial n} \right] \frac{1}{|\mathbf{r} - \mathbf{r}'|} + [\psi] \frac{\partial}{\partial n} \frac{1}{|\mathbf{r} - \mathbf{r}'|} \right. \\ & \quad \left. - \frac{1}{c} \left[\frac{\partial \psi}{\partial t} \right] \frac{1}{|\mathbf{r} - \mathbf{r}'|} \frac{\partial |\mathbf{r} - \mathbf{r}'|}{\partial n} \right\} dS \quad (16) \end{aligned}$$

where $[f]$ denotes the value of the function f at time $t - |\mathbf{r} - \mathbf{r}'|/c$. In particular the solution of equation (1) satisfying the conditions

$$\psi = \frac{\partial \psi}{\partial t} = 0 \quad \text{on } S$$

is

$$\psi(\mathbf{r}, t) = \frac{1}{4\pi} \int_{\Omega} \frac{[f] d\tau'}{|\mathbf{r} - \mathbf{r}'|} \quad (17)$$

Because of its physical interpretation $[f]$ is known as the *retarded value* of f , and the expression on the right-hand side of equation (17) is called a *retarded potential*. It will be observed that by a simple change of variable in the integral on the right equation (17) can be written in the form

$$\psi(\mathbf{r}, t) = \frac{1}{4\pi} \int_{\Omega} \frac{f(\mathbf{r} + \mathbf{r}', t - |\mathbf{r}'|/c)}{|\mathbf{r}'|} d\tau' \quad (18)$$

The equation (17) may be established by means of the theory of Fourier transforms; for a proof by this method the reader is referred to Sec. 39.2 of Sneddon's "Fourier Transforms."

It should be emphasized here that the derivation of equation (17) which we have given is not rigorous. Among other things, we have supposed the arbitrary function F to be differentiable and have then taken a form for F which does not satisfy this condition. In fact the final F we have chosen is not a function at all in the ordinary sense of the word but a Dirac delta function.¹ We shall give a rigorous derivation of this formula in the next section. In the remainder of this section we shall merely indicate how the solution may be applied to the solution of specific problems.

We saw in Prob. 1 of Sec. 2 of Chap. 3 that Maxwell's equations of the electromagnetic field possess solutions of the form

$$\mathbf{H} = \text{curl } \mathbf{A}, \quad \mathbf{E} = -\frac{1}{c} \frac{\partial \mathbf{A}}{\partial t} - \text{grad } \phi \quad (19)$$

where the vector potential \mathbf{A} and the scalar potential ϕ satisfy the nonhomogeneous wave equations

$$\mathbf{L} \mathbf{A} = \frac{4\pi}{c} \mathbf{i} \quad (20)$$

$$\mathbf{L} \phi = 4\pi\rho \quad (21)$$

respectively. In these equations \mathbf{i} denotes the current density, and ρ is the space-charge density. It follows immediately from equation (17) that if \mathbf{A} , ϕ , $\partial \mathbf{A} / \partial t$, and $\partial \phi / \partial t$ vanish on the infinite sphere, then

$$\mathbf{A} = \frac{1}{c} \int \frac{[\mathbf{i}]}{|\mathbf{r} - \mathbf{r}'|} d\tau' \quad (22)$$

and

$$\phi = \int \frac{[\rho]}{|\mathbf{r} - \mathbf{r}'|} d\tau' \quad (23)$$

where the integrals are taken throughout the whole of space.

Example 7. Determine the vector potential and scalar potential at a point \mathbf{r} due to a point charge q at the point \mathbf{r}_0 moving with velocity \mathbf{v} ($v \ll c$).

We may suppose that a point charge q is distributed uniformly throughout the volume of a small sphere of radius ϵ . We may therefore write

$$\mathbf{i}(\mathbf{r}, t) = q f(\mathbf{r}) \mathbf{v}(t), \quad \rho(\mathbf{r}, t) = q f(\mathbf{r}) \quad (24)$$

where

$$\mathbf{v} = \frac{d\mathbf{r}_0}{dt'}, \quad t' = t - \frac{|\mathbf{r} - \mathbf{r}_0|}{c} \quad (25)$$

and

$$f(\mathbf{r}) = \begin{cases} \frac{3}{4\pi\epsilon^3} & \text{if } |\mathbf{r} - \mathbf{r}_0| < \epsilon \\ 0 & \text{if } |\mathbf{r} - \mathbf{r}_0| > \epsilon \end{cases}$$

Substituting in equation (22), we find that

$$\mathbf{A} = \frac{3q}{4\pi c \epsilon^3} \int_S \frac{\mathbf{v} \left(t - \frac{|\mathbf{r} - \mathbf{r}'|}{c} \right)}{|\mathbf{r} - \mathbf{r}'|} d\tau'$$

¹ I. N. Sneddon, "Fourier Transforms" (McGraw-Hill, New York, 1951), p. 32.

where S is the sphere $|\mathbf{r}' - \mathbf{r}_0| < \epsilon$. If we make the transformation

$$(\lambda, \mu, \nu) = \boldsymbol{\lambda} = \mathbf{r}' - \mathbf{r}_0$$

in this integral, then since

$$\frac{\partial \lambda}{\partial x'} = 1 - \frac{\partial x_0}{\partial t'} \frac{\partial t'}{\partial x'} = 1 + \frac{(x' - x)v_x}{c|\mathbf{r} - \mathbf{r}'|}, \text{ etc.}$$

we find that for small values of v/c

$$\frac{\partial(\lambda, \mu, \nu)}{\partial(x', y', z')} = 1 - \frac{\mathbf{v} \cdot (\mathbf{r} - \mathbf{r}')}{c|\mathbf{r} - \mathbf{r}'|}$$

so that

$$\frac{d\tau'}{c|\mathbf{r} - \mathbf{r}'|} = \frac{d\lambda d\mu d\nu}{c|\mathbf{r} - \mathbf{r}_0 - \boldsymbol{\lambda}| - \mathbf{v} \cdot (\mathbf{r} - \mathbf{r}_0 - \boldsymbol{\lambda})}$$

and

$$\mathbf{A} = \frac{3q}{4\pi\epsilon^3} \int_S \frac{\mathbf{v} \left(t - \frac{|\mathbf{r} - \mathbf{r}_0 - \boldsymbol{\lambda}|}{c} \right) d\lambda d\mu d\nu}{c|\mathbf{r} - \mathbf{r}_0 - \boldsymbol{\lambda}| - \mathbf{v} \cdot (\mathbf{r} - \mathbf{r}_0 - \boldsymbol{\lambda})}$$

S having equation $|\boldsymbol{\lambda}| = \epsilon$ in these coordinates. Making use of the mean-value theorem and letting $\epsilon \rightarrow 0$, we find that

$$\mathbf{A}(\mathbf{r}, t) = \frac{q\mathbf{v}(t')}{cR - \mathbf{R} \cdot \mathbf{v}(t')} \quad (26)$$

where we have written $\mathbf{R} = \mathbf{r}_0 - \mathbf{r}$, $t' = t - R/c$.

Similarly we have, for the scalar potential,

$$\phi = \frac{3qc}{4\pi\epsilon^3} \int_S \frac{d\lambda d\mu d\nu}{c|\mathbf{r} - \mathbf{r}_0 - \boldsymbol{\lambda}| - \mathbf{v} \cdot (\mathbf{r} - \mathbf{r}_0 - \boldsymbol{\lambda})}$$

which becomes in the limit $\epsilon \rightarrow 0$

$$\phi = \frac{cq}{cR - \mathbf{R} \cdot \mathbf{v}(t')} \quad (27)$$

In the nonrelativistic range of velocities $v \ll c$ we have the approximate expressions

$$\mathbf{A} = \frac{q\mathbf{v}(t')}{cR}, \quad \phi = \frac{q}{R} \quad (28)$$

The potentials given by equations (26) and (27) are known as the *Lienard-Wiechert potentials*.

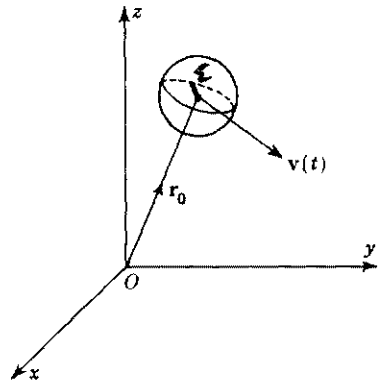

Figure 43

PROBLEMS

1. A current is suddenly started at time $t = 0$ in an infinitely long straight conducting wire, and its magnitude at a subsequent time t is $i(t)$. Show that at a point P distant r from the wire the vector potential \mathbf{A} at time t is zero if $r > ct$ but that if $r < ct$, \mathbf{A} is directed along the wire and has magnitude

$$\frac{2}{c} \int_0^{t-r/c} \frac{i(\tau) d\tau}{\sqrt{(t-\tau)^2 - r^2/c^2}}$$

2. If $f(\mathbf{r})$ is the limit as $\epsilon \rightarrow 0$ of the function

$$f_\epsilon(\mathbf{r}) = \begin{cases} \frac{3}{4\pi\epsilon^3} & |\mathbf{r}| < \epsilon \\ 0 & |\mathbf{r}| > \epsilon \end{cases}$$

show that

$$\psi(\mathbf{r}, t) = \frac{e^{i(\mathbf{r} \cdot \mathbf{r}' - ct)}{4\pi r}$$

is a solution of the equation $\mathcal{L}\psi = f(\mathbf{r})e^{-i\omega t}$.

3. The D function of quantum electrodynamics satisfies $(\mathcal{L} - k^2)D = 0$ and the initial conditions $D(\mathbf{r}, t) = 0$, $\partial D/\partial t = f(\mathbf{r})$ at $t = 0$, where $f(\mathbf{r})$ is the function defined in the last problem. Show that

$$D(\mathbf{r}, t) = -\frac{1}{4\pi cr} \frac{\partial}{\partial t} F(\mathbf{r}, t)$$

where the function $F(\mathbf{r}, t)$ is defined by the equations

$$F(\mathbf{r}, t) = \begin{cases} J_0[k(c^2t^2 - r^2)^{1/2}] & ct > r \\ 0 & -r < ct < r \\ -J_0[k(c^2t^2 + r^2)^{1/2}] & ct < -r \end{cases}$$

9. Riesz's Integrals

It was observed in the last section that the derivation of equation (17) of that section was not rigorous. In this section we shall give a brief account of a method due to Marcel Riesz which provides a rigorous proof of this formula and also of the corresponding two-dimensional problem. We shall also indicate how the method can be applied to the solution of Poisson's equation.

In two short papers¹ read at the Oslo congress in 1936, Riesz introduced two generalizations of the Riemann-Liouville integral of fractional order. The first generalization associated with the operator

$$\mathcal{L} = \frac{\hat{\gamma}^2}{\hat{\gamma}t^2} - \nabla^2 \quad (1)$$

is

$$I^n \psi(\mathbf{r}, t) = \frac{2^{1-n}}{\pi \Gamma(\frac{1}{2}n) \Gamma(\frac{1}{2}n - 1)} \int_D \psi(\mathbf{r}', t') R^{n-1} d\tau' dt' \quad (2)$$

where $d\tau' = dx' dy' dz'$, $R^2 = (t - t')^2 - |\mathbf{r} - \mathbf{r}'|^2$, and D is the hypervolume bounded by the hypersurface $R = 0$ and the hyperplane $t' = 0$. The time variable t is always reckoned to be positive.

The fundamental properties of the integral (2) were stated without proof by Riesz, but brief indications of proofs of these results under conditions sufficiently general for their use in theoretical physics have been given by Copson.² If the function ψ is continuous the integral $I^n \psi$ is an analytic function of the complex variable n for $\text{Re}(n) > 2$. The

¹ M. Riesz, *Compt. rend. congr. intern. math., Oslo, 1936*, vol. ii, pp. 45 and 62.

² E. T. Copson, *Proc. Roy. Soc. Edinburgh*, **59A**, 260 (1943).

characteristic properties of the Riesz integral (2) are expressed by the equations

$$I^n I^n \psi = I^{n-2} \psi, \tag{3}$$

$$L I^{n-2} \psi = I^n \psi \tag{4}$$

If ψ and $\partial\psi/\partial t$ vanish when $t = 0$, then

$$I^{n+2} L \psi = I^n \psi \tag{5}$$

$$\lim_{n \rightarrow 0} I^n \psi = \psi \tag{6}$$

Comparing equations (3) and (4), it appears that, in some sense, the operator L is I^{-2} .

In the particular case $n = 2$ it can be shown by simple changes of variable that

$$I^2 \psi(\mathbf{r}, t) = \frac{1}{4\pi} \int \frac{\psi(\mathbf{r} - \mathbf{r}', t - |\mathbf{r}'|)}{|\mathbf{r}'|} d\tau' \tag{7}$$

where the integration is taken over $0 \leq |\mathbf{r}'| \leq t$.

As an example of the use of these results we consider the problem of solving the nonhomogeneous wave equation

$$L \psi = f(\mathbf{r}, t) \quad t > 0 \tag{8}$$

subject to the initial conditions $\psi = \partial\psi/\partial t = 0$ at $t = 0$, it being assumed that f and $\partial f/\partial t$ are continuous. It follows from equation (5) that

$$I^n \psi' = I^{n+2} f$$

If, now, we let $n \rightarrow 0$ and make use of equations (6) and (7), we find that

$$\psi = I^2 f = \frac{1}{4\pi} \int \frac{f(\mathbf{r} - \mathbf{r}', t - |\mathbf{r}'|)}{|\mathbf{r}'|} d\tau' \tag{9}$$

in agreement with equation (18) of the last section. It will be observed that this is precisely the solution we should have obtained if we had interpreted L as I^{-2} and proceeded symbolically.

For the corresponding two-dimensional problem associated with the operator

$$L_1 = \frac{\partial^2}{\partial t^2} - \nabla_1^2 \tag{10}$$

Riesz introduced the integral

$$I_1^n \psi(\rho, t) = \frac{1}{2\pi \Gamma(n-1)} \int_{D_1} \psi(\rho', t') R_1^{n-3} dx' dy' dt' \tag{11}$$

where ρ denotes the plane vector (x, y) ,

$$R_1^2 = (t - t')^2 - |\rho - \rho'|^2$$

and D_1 is the volume in the $x'y't'$ space bounded by the plane $t' = 0$ and the cone

$$|\rho - \rho'| = c(t - t')$$

This integral has the properties

$$I_1'' I_1'' \psi = I_1'' \Delta \psi \tag{12}$$

$$L_1 I_1'' \Delta \psi = I_1'' \psi \tag{13}$$

$$\lim_{\mu \rightarrow 0} I_1'' \psi = \psi \tag{14}$$

from which it follows that a solution of the nonhomogeneous two-dimensional wave equation

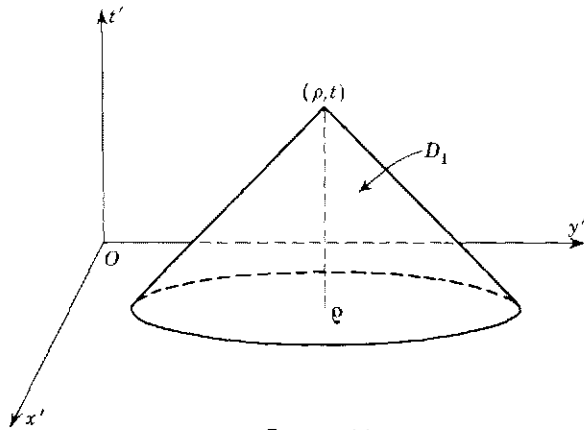

Figure 44

$$L_1 \psi(\rho, t) = f(\rho, t) \quad t > 0 \tag{15}$$

is

$$\psi(\rho, t) = \frac{1}{2\pi} \int_{D_1} \frac{\psi(\rho', t') dx' dy' dz'}{R_1} \tag{16}$$

The second Riesz integral, associated with the operator ∇^2 , is defined by the equation

$$J^n \psi(\mathbf{r}) = \frac{\Gamma(\frac{3}{2} - \frac{1}{2}n)}{2^n \pi^{3/2} \Gamma(\frac{1}{2}n)} \int \frac{\psi(\mathbf{r}')}{|\mathbf{r} - \mathbf{r}'|^{3-n}} d\tau' \tag{17}$$

the integration being taken over the whole of space. If ψ is a continuous function such that $J^n \psi$ exists in a strip $0 < R(n) < k$ of the complex n plane, then

$$J^m J^n \psi = J^{m+n} \psi \tag{18}$$

$$\nabla^2 J^{n-2} \psi = -J^n \psi \tag{19}$$

$$\lim_{n \rightarrow 0} J^n \psi = \psi \tag{20}$$

Thus if we have to solve Poisson's equation

$$\nabla^2 \psi(\mathbf{r}) = -4\pi \rho(\mathbf{r})$$

then operating on both sides of the equation by J^{n+2} and letting $n \rightarrow 0$, we find that

$$\psi(\mathbf{r}) = 4\pi J^2 \rho(\mathbf{r})$$

which from equation (10) becomes

$$\psi(\mathbf{r}) = \int \frac{\rho(\mathbf{r}') d\tau'}{|\mathbf{r} - \mathbf{r}'|} \tag{21}$$

PROBLEMS

1. Show that the solution of the equation

$$(\mathbf{L} + k^2)\psi(\mathbf{r}, t) = f(\mathbf{r}, t)$$

with $\psi = \partial\psi/\partial t = 0$ when $t = 0$, can be written symbolically in the form

$$\psi(\mathbf{r}, t) = \sum_{\tau=0}^{\infty} (-1)^\tau k^{2\tau} I^{2\tau+2} f$$

Deduce that

$$\psi(\mathbf{r}, t) = \frac{1}{4\pi} \int_V \frac{f(\mathbf{r}', t - |\mathbf{r} - \mathbf{r}'|) d\tau'}{|\mathbf{r} - \mathbf{r}'|} - \frac{k}{4\pi} \int_D \frac{f(\mathbf{r}', t')}{R} J_1(kR) d\tau' dt'$$

where $R^2 = (t - t')^2 - |\mathbf{r} - \mathbf{r}'|^2$, V is the volume for which $0 < |\mathbf{r} - \mathbf{r}'| < t$, and D is the hypervolume bounded by $R = 0$ and $t' = 0$.

2. Show that the solution of the equation

$$(\mathbf{L}_1 - k^2)\psi(\mathbf{p}, t) = f(\mathbf{p}, t)$$

with $\psi = \partial\psi/\partial t = 0$ when $t = 0$, can be written symbolically in the form

$$\psi(\mathbf{p}, t) = \sum_{\tau=0}^{\infty} k^{2\tau} I_1^{2\tau+2} f(\mathbf{p}, t)$$

Deduce that

$$\psi(\mathbf{p}, t) = \frac{1}{2\pi} \int_{D_1} f(\mathbf{p}', t') \frac{\cosh(kR_1)}{R_1} dx' dy' dt'$$

where $R_1^2 = (t - t')^2 - |\mathbf{p} - \mathbf{p}'|^2$ and D_1 is the volume in the $x'y't'$ space bounded by the plane $t' = 0$ and the cone $R_1^2 = 0$.

10. The Propagation of Sound Waves of Finite Amplitude

The problems of wave propagation which we have been considering in this chapter have been concerned with linear partial differential equations. We shall conclude this chapter by considering an important nonlinear problem, that of describing the motion of a gas when a sound wave of finite amplitude is being propagated through it. We shall consider only the one-dimensional problem, since it lends itself

to a simple linearization procedure and provides a useful illustration of the use of the Riemann-Volterra method and of a complex variable method due to Copson. Even this simple problem has important applications in aerodynamics and astrophysics.

The one-dimensional motion of a gas obeying the adiabatic law

$$p = k\rho^\gamma \quad (1)$$

is governed by the momentum equation

$$\frac{\partial u}{\partial t} + u \frac{\partial u}{\partial x} = -\frac{1}{\rho} \frac{\partial p}{\partial x} \quad (2)$$

and the continuity equation

$$\frac{\partial \rho}{\partial t} + u \frac{\partial \rho}{\partial x} + \rho \frac{\partial u}{\partial x} = 0 \quad (3)$$

If we introduce the local velocity of sound c through the relations

$$c^2 = \frac{dp}{d\rho} = k\gamma\rho^{\gamma-1} \quad (4)$$

we find that equation (2) becomes

$$\frac{\partial u}{\partial t} + u \frac{\partial u}{\partial x} + \frac{2c}{\gamma-1} \frac{\partial c}{\partial x} = 0 \quad (5)$$

and that equation (3) becomes

$$\frac{2}{\gamma-1} \left(\frac{\partial c}{\partial t} + u \frac{\partial c}{\partial x} \right) + c \frac{\partial u}{\partial x} = 0 \quad (6)$$

If we let

$$r = \frac{c}{\gamma-1} + \frac{1}{2}u, \quad s = \frac{c}{\gamma-1} - \frac{1}{2}u \quad (7)$$

i.e., if we put

$$c = \frac{1}{2}(\gamma-1)(r+s), \quad u = r-s \quad (8)$$

then the equations (5) and (6) reduce to the pair

$$\frac{\partial r}{\partial t} - (\alpha r + \beta s) \frac{\partial r}{\partial x} = 0, \quad \frac{\partial s}{\partial t} - (\alpha s + \beta r) \frac{\partial s}{\partial x} = 0 \quad (9)$$

where $\alpha = \frac{1}{2}(\gamma+1)$, $\beta = \frac{1}{2}(\gamma-3)$.

The quantities r and s defined by the pair of equations (7) are called *Riemann invariants*. If one of the Riemann invariants is a constant, then one equation of the pair (9) is an identity, and the other is a first-order equation of Lagrange type, by means of which the other invariant may be determined. The gas flow corresponding to the solution so obtained is called a simple wave. For instance, if r is constant, then

$$x + (\alpha s + \beta r)t = f(s)$$

where the function f is arbitrary, and if s is constant,

$$x = (\alpha r + \beta s)t + g(r)$$

where g is arbitrary.

Riemann showed that if r and s are taken as independent variables, the problem can be linearized. If x and t are expressed in terms of r and s , then it is readily shown that

$$\frac{\partial r}{\partial x} = J \frac{\partial t}{\partial s}, \quad \frac{\partial r}{\partial t} = -J \frac{\partial x}{\partial s}, \quad \frac{\partial s}{\partial x} = -J \frac{\partial t}{\partial r}, \quad \frac{\partial s}{\partial t} = J \frac{\partial x}{\partial r}$$

where $J = \partial(r,s)/\partial(x,t)$. If we substitute these expressions in equations (9), we find that these equations may be written in the form

$$\frac{\partial}{\partial s} [x - (\alpha r + \beta s)t] + \beta t = 0, \quad \frac{\partial}{\partial r} [x + (\alpha s + \beta r)t] - \beta t = 0$$

from which it follows that these equations are satisfied if we express the original independent variables x and t in terms of r and s by the equations

$$x - (\alpha r + \beta s)t = \frac{\partial \phi}{\partial r}, \quad x + (\alpha s + \beta r)t = -\frac{\partial \phi}{\partial s} \tag{10}$$

where the function ϕ satisfies the equation

$$\frac{\partial^2 \phi}{\partial r \partial s} + \frac{N}{r+s} \left(\frac{\partial \phi}{\partial r} + \frac{\partial \phi}{\partial s} \right) = 0 \tag{11}$$

in which
$$N = -\frac{\beta}{\alpha - \beta} = \frac{3 - \gamma}{2(\gamma - 1)} \tag{12}$$

so that
$$\gamma = \frac{2N + 3}{2N + 1} \tag{13}$$

If N is a positive integer, a solution of equation (11) can be obtained in closed form. Consider the expression

$$\phi_1 = \frac{\partial^{N-1}}{\partial r^{N-1}} \frac{f(r)}{(r+s)^N}$$

where the function $f(r)$ is arbitrary. By direct differentiation it is readily shown that

$$\begin{aligned} & \frac{\partial^2 \phi_1}{\partial r \partial s} - \frac{N}{r+s} \left(\frac{\partial \phi_1}{\partial r} + \frac{\partial \phi_1}{\partial s} \right) \\ &= -N \frac{\partial^N}{\partial r^N} \frac{f(r)}{(r+s)^{N+1}} + \frac{N}{r+s} \left(\frac{\partial^N}{\partial r^N} \frac{f(r)}{(r+s)^N} - N \frac{\partial^{N-1}}{\partial r^{N-1}} \frac{f(r)}{(r+s)^{N+1}} \right) \end{aligned}$$

Now if we write

$$\frac{f(r)}{(r+s)^N} = \frac{f(r)}{(r+s)^{N-1}} (r+s)$$

and make use of Leibnitz's theorem for the n th derivative of a product, we find that

$$\frac{\partial^N}{\partial r^N} \frac{f(r)}{(r+s)^N} = (r+s) \frac{\partial^N}{\partial r^N} \frac{f(r)}{(r+s)^{N+1}} + N \frac{\partial^{N-1}}{\partial r^{N-1}} \frac{f(r)}{(r+s)^{N+1}}$$

from which it follows that ϕ_1 is a solution of equation (11). A similar solution can be obtained by interchanging r and s . We therefore have

$$\phi(r,s) = \frac{\partial^{N-1}}{\partial r^{N-1}} \frac{f(r)}{(r+s)^N} + \frac{\partial^{N-1}}{\partial s^{N-1}} \frac{g(s)}{(r+s)^N} \tag{14}$$

where $f(r)$ and $g(s)$ are arbitrary, as the solution of the linear equation (13) in the case in which N is a positive integer. In the case $N = 1$ we have the simple solution

$$\phi(r,s) = \frac{f(r) + g(s)}{r+s}$$

For general values of the constant γ , N is not an integer, and so recourse has to be made to some other method of solution, such as the Riemann-Volterra method. It follows from the analysis of Sec. 8 of Chap. 3 that, in the notation of Fig. 45, the solution of equation (11) is

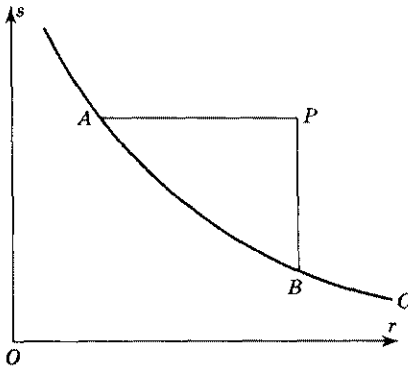

Figure 45

$$\phi_P = \phi_B w_B - \int_{AB} \left[w \left\{ \frac{\partial \phi}{\partial s'} + \frac{N}{r'+s'} \phi \right\} ds' + \phi \left\{ \frac{\partial w}{\partial r'} - \frac{Nw}{r'+s'} \right\} dr' \right]$$

where ϕ , $\partial\phi/\partial r$, and $\partial\phi/\partial s$ are prescribed along a curve C in the rs plane and the Green's function $w(r,s;r',s')$ is determined by the equations

$$(i) \quad \frac{\partial^2 w}{\partial r \partial s} - N \frac{\partial}{\partial r} \left(\frac{w}{r+s} \right) - N \frac{\partial}{\partial s} \left(\frac{w}{r+s} \right) = 0$$

$$(ii) \quad \frac{\partial w}{\partial r} = \frac{N}{r+s} w \quad \text{when } s = s'$$

$$(iii) \quad \frac{\partial w}{\partial s} = \frac{N}{r+s} w \quad \text{when } r = r'$$

$$(iv) \quad w = 1 \quad \text{when } r = r' \text{ and } s = s'$$

It can be shown that

$$w(r,s;r',s') = \left(\frac{r'+s'}{r+s} \right)^N {}_2F_1(1-N, N; 1; \xi) \tag{15}$$

where
$$\xi = -\frac{(r-r')(s-s')}{(r+s)(r'+s')} \tag{16}$$

An alternative method of solution has been devised by Copson,¹ using the theory of functions of a complex variable. It is easily proved that the function

$$\phi(r, s) = \frac{z^{2N}}{(z-r)^N(z+s)^N}$$

is a solution of Riemann's equation (11). Furthermore if r and s are real and N is not an integer, this solution is an analytic function of the complex variable z , which is regular if the z plane is cut along the segment of the real axis which joins the points $0, r, -s$. We may then consider the branch of this function which is real and positive when z is real and greater than $0, r$, and $-s$. Therefore, if $f(z)$ is an analytic function which is regular in a region containing the real axis, and if C is a simple closed contour surrounding the cut, then

$$\phi(r, s) = \frac{1}{2\pi i} \int_C \frac{z^{2N} f(z) dz}{(z-r)^N(z+s)^N} \quad (17)$$

is also a solution of the partial differential equation (11). Substituting this expression in equations (10), we find that

$$x - (zr + \beta s)t = \frac{N}{2\pi i} \int_C \frac{z^{2N} f(z) dz}{(z-r)^{N-1}(z+s)^N} \quad (18)$$

$$x + (zs - \beta r)t = \frac{N}{2\pi i} \int_C \frac{z^{2N} f(z) dz}{(z-r)^N(z+s)^{N-1}} \quad (19)$$

from which it follows that

$$(x + \beta t) = -\frac{N}{2\pi i} \int_C \frac{z^{2N} f(z) dz}{(z-r)^{N-1}(z+s)^{N-1}}$$

Now in a state of rest the velocity u is zero so that $r = -s$. Hence if the solution (17) is to represent a motion of the gas in which the initial state is a state of rest, the function $f(z)$ must be chosen to satisfy the integral equation

$$\int_{\Gamma} \frac{z^{2N} f(z) dz}{(z^2 - r^2)^{N-1}} = 0.$$

where Γ is a simple closed contour surrounding the cut $|\operatorname{Re}(z)| \leq r$. It is readily shown that this implies that $f(z)$ is an even function, and conversely.

Suppose that when $t = 0$, $x = x_0(r)$; then equations (18) and (19) show that

$$x_0(r) = \frac{N}{2\pi i} \int_{\Gamma} \frac{z^{2N} f(z) dz}{(z-r)^{N-1}(z+r)^N} = \frac{N}{2\pi i} \int_{\Gamma} \frac{z^{2N} f(z) dz}{(z-r)^N(z+r)^{N-1}}$$

from which we obtain by addition the symmetrical expression

$$x_0(r) = \frac{N}{2\pi i} \int_{\Gamma} \frac{z^{2N+1} f(z) dz}{(z^2 - r^2)^{N-1}} \quad (20)$$

¹ E. T. Copson, *Proc. Roy. Soc. London*, **216A**, 539 (1953).

Equation (20) can be regarded as an integral equation for the determination of $f(z)$ when $x_0(r)$ is known. Copson has shown that the solution of this equation is

$$z^{2N}f(z) = 2 \int_0^z r(z^2 - r^2)^{N-1} x_0(r) dr \quad (21)$$

provided that $x_0(r)$, regarded as a function of the complex variable r , is an even function regular in a region containing the real axis. Equation (17) then gives the required function $\phi(r, s)$.

PROBLEMS

1. In the problem of the expansion of a gas cloud into a vacuum the initial conditions are

$$r - s = r_0(x) \quad x \leq 0, \quad r_0(0) = 0$$

Show that

$$\left(\frac{\partial u}{\partial t} \right)_{t=0} = -2(\gamma - 1)r_0(x) \frac{dr_0}{dx}$$

Hence show that if $r'_0(x) > 0$, the cloud expands into the vacuum.

2. If the face of the expanding cloud has advanced into the vacuum and is at $x = x_1(t)$, show that the conditions $r = -s = r_1(t)$ hold there. Deduce that

$$x_1 - 2r_1 t = \frac{N}{2\pi i} \int_{C_1} \frac{z^{2N} f(z) dz}{(z - r_1)^{2N-1}}$$

where

$$(z - \beta)t = \frac{N}{2\pi i} \int_{C_1} \frac{z^{2N} f(z) dz}{(z - r_1)^{2N-1}}$$

and C_1 is a simple closed contour surrounding O and r_1 .

Prove that $\dot{x}_1 = 2r_1$; i.e., the velocity with which the face of the cloud advances is equal to the particle velocity at the face.

3. If $N = \frac{1}{2}$, prove that

$$x_1 - 2r_1 t = \frac{1}{2} \frac{d}{dr_1} [r_1 f(r_1)], \quad t = \frac{1}{4} \frac{d^2}{dr_1^2} [r_1 f(r_1)]$$

4. If initially $r = s = (-\mu x)^{\frac{1}{2}}$, $x \leq 0$, prove that

$$x = \frac{1}{2\mu} [Nr^2 - 2(N-1)rs + Ns^2], \quad t = \frac{1}{2\mu} (2N-1)(r-s)$$

Deduce that the position x_1 of the face of the cloud at time t is given by

$$x_1 = \frac{\mu t^2}{2N-1}$$

MISCELLANEOUS PROBLEMS

1. Two very long uniform strings are connected together and stretched in a straight line with tension T ; they carry a particle of mass m at their junction. A train of simple harmonic transverse waves of frequency ν travels along one

of the strings and is partially reflected and partially transmitted at the junction. Find the amplitude of the transmitted wave, and prove that its phase lags behind that of the incident wave by an amount

$$\tan^{-1} \left\{ \frac{2\pi v m c c'}{T(c - c')} \right\}$$

where c and c' are the velocities of propagation in the two strings.

Verify that the mean energy of the incident wave is equal to the sum of the mean energies of the reflected and transmitted waves.

2. A uniform straight rod of mass m and length l is free to rotate in a horizontal plane about one end A , which is fixed on a smooth horizontal table. The other end of the rod is tied to one end of a heavy string. The other end of the string is tied to a fixed point B on the table so that $AB = 2l$. Initially the rod and the string are in a straight line, in which position the tension in the string is F , and its density is ρ per unit length. The system is set in motion so that it performs small transverse vibrations in a horizontal plane.

Show that the periodic times of normal modes of vibration are given by $2\pi l/c\xi$, where ξ satisfies the equation

$$\xi \tan \xi = \frac{3\rho l}{m}$$

3. A uniform string of line density ρ and length l has one end fixed and the other attached to a bead of mass m free to move on a rough rigid wire perpendicular to the string. The rough wire exerts a frictional force on the bead equal to μ times its velocity. If $x = 0$ is the fixed end of the string, and if the effect of gravity can be neglected, show that the displacement of any point of the string in transverse vibration can be expressed as the real part of $e^{i(\rho l - \nu t)} y(x)$, where p satisfies the equation

$$mp = i\mu + c\rho \cot \frac{pl}{c}$$

If μ is small, show that the approximate value of p is

$$n = \frac{i\mu}{m + \rho l \operatorname{cosec}^2 nl/c}$$

where $nm = c\rho \cot nl/c$.

4. A cylindrical tube of small radius, open at both ends, is divided into two parts of lengths l_1, l_2 by a piston of small thickness δ and density σ attached to a spring such that *in vacuo* the period of vibration is $2\pi/m$. Show that when the tube is in air of density ρ , the period of vibration becomes $2\pi/n$, where

$$\sigma(m^2 - n^2)\delta = \rho cn \tan \frac{nl_1}{c} + \tan \frac{nl_2}{c}$$

and c denotes the speed of sound.

5. Show that the only solution of the one-dimensional wave equation which is homogeneous of degree zero in x and t is of the form

$$A \log \left(\frac{x - ct}{x + ct} \right) + B$$

where A and B are arbitrary constants.

6. Find a solution of $\partial^2 y / \partial t^2 = c^2 (\partial^2 y / \partial x^2)$ such that:
 - (i) y involves x trigonometrically;
 - (ii) $y = 0$ when $x = 0$ or π , for all values of t ;
 - (iii) $\partial y / \partial t = 0$ when $t = 0$, for all values of x ;
 - (iv) $y = \sin x$ from $x = 0$ to $x = \pi/2$, $y = 0$ from $x = \pi/2$ to $x = \pi$ when $t = 0$.
7. Two equal and opposite impulses of magnitude I are applied normally to the points of trisection of a string of density ρ per unit length stretched to a tension T between two points at a distance l apart. Derive an expression for the displacement of the string at any subsequent instant, and show that the mid-point of the string remains at rest.
8. Find a solution of the equation

$$\frac{1}{c^2} \frac{\partial^2 V}{\partial t^2} = \frac{\partial^2 V}{\partial x^2}$$

such that $V = 0$ when $x = 0$ or $x = a$ for all values of t and that $\partial V / \partial t = 0$ when $t = 0$ and $V = E$ when $t = 0$ for all values of x between 0 and a . The quantities a , c , and E are constants.

9. Find a solution of

$$\frac{\partial^2 u}{\partial x^2} - \frac{\partial^2 u}{\partial t^2} = xt$$

satisfying the conditions $u = \partial u / \partial t = 0$ when $t = 0$.

10. One end of a string ($x = 0$) is fixed, and the point $x = a$ is made to oscillate so that at time t its displacement is $Y(t)$. Prove that the displacement of the point x at time t is

$$f(ct - x) - f(ct + x)$$

where f is a function which satisfies the relation

$$f(z - 2a) = f(z) - Y\left(\frac{z - a}{c}\right)$$

for all values of z .

A string is constrained to move in two different ways; in case 1 the point $x = a$ is given a displacement $Y(t)$, and in case 2 the point $x = b$ is given an identical displacement. It is found that the shape of the string in case 1 is identical with that in case 2 at all times; show that the displacement at $x = b$ in case 1 is equal to that of $x = a$ in case 2.

11. Show that the equation governing small transverse motions of a nonuniform string is of the form

$$c^2 \frac{\partial^2 y}{\partial x^2} = \frac{\partial^2 y}{\partial t^2}$$

where c is a function of x .

Show that a solution of this is $y = f(x, t) = F(x, t)$, where

$$\frac{\partial f}{\partial x} - \frac{1}{c} \frac{\partial f}{\partial t} = \frac{1}{2c} \frac{\partial c}{\partial x} (f - F) = - \frac{\partial F}{\partial x} + \frac{1}{c} \frac{\partial F}{\partial t}$$

and interpret this, in a region in which $\partial c / \partial x$ is small, as the sum of two progressive waves whose form is slowly altering.

An infinite string is such that $x < 0$ or $x > a$; between $x = 0$ and $x = a$, $(a/c) \partial c / \partial x$ is everywhere small. A wave $y = f_0(t - x/c)$

is propagated along the string from $x = x_0$. Show that a first approximation to the form of the string is given by $f(x, t) = f_0(t - \theta)$, $F(x, t) = 0$, where $\theta = \int_0^x c^{-1} dx$, and that a second approximation is given by

$$f = f_0(t - \theta) \left\{ 1 - \frac{1}{2} [\log c(x) - \log c(0)] \right\}, \quad F = \phi(t + \theta, x)$$

where $\phi(u, x)$ is given by

$$\phi(u, x) = \frac{1}{2} \int_x^a f_0(u - 2\theta) \frac{c'}{c} dx$$

12. A string of nonuniform density $\rho(x)$ is fixed at two points $x = 0$ and $x = a$, the tension of the string being $c^2\rho_0$. If the density $\rho(x)$ varies only slightly from the value ρ_0 , show that, to the first order of small quantities, the normal periods of vibration are

$$\frac{2}{rc\rho_0} \int_0^a [\rho_0 - \rho(x)] \sin^2 \frac{r\pi x}{a} dx$$

and the normal functions (apart from a normalizing factor) are

$$\sin \frac{r\pi x}{a} + \frac{2}{a} \sum_{s \neq r} 2\alpha_s \frac{r^2}{s^2 - r^2} \sin \frac{s\pi x}{l}$$

where r, s are positive integers and

$$\alpha_s = \int_0^a \left(\frac{\rho(x)}{\rho_0} - 1 \right) \sin \left(\frac{s\pi x}{a} \right) \sin \left(\frac{r\pi x}{a} \right) dx$$

13. A uniform string of mass M is stretched between two fixed points at distance a apart, and carries a small mass ϵM at a distance b from one end. Show that, to the first order in ϵ , the periods of the normal modes are

$$\frac{2a}{rc} \left(1 - \epsilon \sin^2 \left(\frac{r\pi b}{a} \right) \right)$$

and the normal functions are proportional to

$$\sin \left(\frac{r\pi x}{a} \right) + 2\epsilon \sin \left(\frac{r\pi b}{a} \right) \sum_{s \neq r} \frac{r^2}{s^2 - r^2} \sin \left(\frac{s\pi b}{a} \right) \sin \left(\frac{s\pi x}{a} \right)$$

Deduce that if the particle is attached to the mid-point of the string, the period of the r th normal mode is unaltered if r is even.

14. A uniform string of line density ρ is stretched at tension ρc^2 between two fixed points at distance a apart. If the mid-point is constrained to vibrate transversely so that its displacement is $\epsilon \cos nt$, where ϵ is small compared with a and na/c is not a multiple of 2π , find the displacement at any time of all points of the string in the resulting forced vibration.

Also show that the mean kinetic energy of the string is

$$\frac{1}{8} n c \epsilon^2 \left(\frac{na}{c} - \sin \frac{na}{c} \right) \operatorname{cosec}^2 \left(\frac{na}{2c} \right)$$

15. A string of length l , with its extremities fixed, is initially at rest and in the form of the curve $y = A \sin m\pi x/l$. At $t = 0$ it begins to vibrate in a resisting

medium. Given that the differential equation governing damped vibrations is

$$c^2 \frac{\partial^2 y}{\partial x^2} - \frac{\partial^2 y}{\partial t^2} - 2k \frac{\partial y}{\partial t}$$

show that, after time t ,

$$y = Ae^{-kt} \left\{ \cos m't + \frac{k}{m'} \sin m't \right\} \sin \frac{m\pi x}{l}$$

where

$$m' = \frac{m^2 \pi^2 c^2}{l^2} - k^2$$

16. A string of length l is vibrating in a resisting medium. The end $x = 0$ is fixed, while the end $x = l$ is made to move so that its displacement is $A \cos (\pi ct/l)$. With the notation of the last problem prove that if k/lc is small, the forced oscillation of the string is described by the equation

$$y = A \operatorname{cosech} \left(\frac{kl}{c} \right) \times \left\{ \sin \left(\frac{\pi x}{l} \right) \cosh \left(\frac{kx}{c} \right) \sin \left(\frac{\pi ct}{l} \right) - \cos \left(\frac{\pi x}{l} \right) \sinh \left(\frac{kx}{c} \right) \cos \left(\frac{\pi ct}{l} \right) \right\}$$

17. Flexural vibrations of a uniform rod are governed by the equation

$$\frac{\partial^4 y}{\partial x^4} - \frac{1}{k^2} \frac{\partial^2 y}{\partial t^2} = 0$$

where k is a constant. Show that if $y = XT$, where X is a function of x alone and T a function of t alone, then T may take the form $A \sin (\lambda kt - \alpha)$, where A, λ, α are constants.

Show that if $y = \partial y / \partial x = 0$ when $x = 0$, then

$$X = B(\cos px - \cosh px) - C(\sin px - \sinh px)$$

where $p^2 = \lambda$ and B, C are constants, and that if also $y = \partial y / \partial x = 0$ when $x = a$, then

$$B(\sin pa - \sinh pa) = C(\cos pa - \cosh pa)$$

and $\cos pa \cosh pa = 1$.

By means of a rough sketch, show that this last equation gives an infinite number of values of λ .

18. If $H(t)$ denotes Heaviside's unit function

$$H(t) = \begin{cases} 0 & t < 0 \\ 1 & t > 0 \end{cases}$$

and if $\bar{y}(\xi)$ is the Laplace transform of a function $y(t)$, show that $e^{-a\xi} \bar{y}(\xi)$ is the Laplace transform of the function $y(t - a)H(t - a)$.

In the equation defining the current i and the voltage E in a cable [equations (3) and (4) of Sec. 2 of Chap. 3] $R/L = G/C = k$, where k is a constant. Both E and i are zero at time $t = 0$, and $E = E_0(t)$ for $x = 0, t > 0$. If V remains finite as x tends to infinity, show that

$$E(x, t) = \begin{cases} E_0 \left(t - \frac{x}{c} \right) e^{-kx/c} & t > \frac{x}{c} \\ 0 & t < \frac{x}{c} \end{cases}$$

19. A membrane is in the form of a right-angle isosceles triangle of area l with fixed boundary. If T is the (uniform) tension and σ is the density per unit area, show that the frequency of the fundamental mode of oscillation is $\pi(5T/2\sigma A)^{1/2}$. What is the frequency of the first harmonic?
20. A rectangular membrane of sides $2a, 2b$ is subjected to a small fluctuating force $P \sin \omega t$ acting at its center. If P and ω are constants and transients are ignored, show that if the axes are chosen symmetrically, the transverse displacement is given by

$$\frac{P \sin \omega t}{c^2 \rho a b} \sum_{r=0}^{\infty} \sum_{s=0}^{\infty} \frac{\cos \left(\frac{2r+1}{2a} \pi x \right) \cos \left(\frac{2s+1}{2b} \pi y \right)}{\left\{ \left(\frac{2r+1}{2a} \pi \right)^2 + \left(\frac{2s+1}{2b} \pi \right)^2 - \frac{\omega^2}{c^2} \right\}}$$

21. A very large membrane, which in its equilibrium position lies in the plane $z = 0$, is drawn into the shape

$$\frac{\varepsilon}{\sqrt{1 - r^2/a^2}}$$

where ε is small, and then released from rest at the instant $t = 0$. Show that at any subsequent instant the transverse displacement is

$$\frac{\varepsilon}{\sqrt{2}} \left\{ \frac{1 - \frac{r^2 - c^2 t^2}{a^2}}{\left(1 - \frac{r^2 - c^2 t^2}{a^2} \right)^2 + 4 \left(\frac{ct}{a} \right)^2} - \frac{1}{\left[\left(1 - \frac{r^2 - c^2 t^2}{a^2} \right)^2 + 4 \left(\frac{ct}{a} \right)^2 \right]^{1/2}} \right\}^{1/2}$$

22. A uniform thin elastic membrane is subjected to a normal external force per unit area $p(x, y, t)$. Prove that the equation governing transverse vibrations is

$$\frac{1}{c^2} \frac{\partial^2 z}{\partial t^2} = \nabla^2 z + \frac{p(x, y, t)}{T}$$

A circular membrane of radius a is deformed by the application of a uniform pressure $P_0 \eta(t)$ to a concentric circle of radius b ($b < a$). If the membrane is set in motion from rest in its equilibrium position at time $t = 0$, prove that at any subsequent time the transverse displacement of the membrane is

$$\frac{2P_0 b}{c \sigma a^2} \sum_j \frac{J_1(b \xi_j) J_0(r \xi_j)}{\xi_j^2 [J_1(\xi_j a)]^2} \int_0^t \eta(u) \sin [c \xi_j (t - u)] du$$

23. If $f(z)$ is a twice-differentiable function of the variable z , prove that the functions $f(x \pm ky - ct)$ are solutions of the two-dimensional wave equation provided that $k^2 = c^2/c^2 - 1$.

Deduce that

$$\psi(x, y, t) = \int z(\alpha) f(x - y \sinh \alpha - ct \cosh \alpha) dz$$

where z is arbitrary, is also a solution.

24. Show that the equations of motion of a two-dimensional elastic medium in the absence of body forces may be reduced by the substitutions

$$u = \frac{\partial \phi}{\partial x} + \frac{\partial \psi}{\partial y}, \quad v = \frac{\partial \phi}{\partial y} - \frac{\partial \psi}{\partial x}$$

to two wave equations.

Making use of the result of the last problem, determine the components of stress in a semi-infinite solid $y \geq 0$ when a moving pulse of pressure of magnitude

$$\frac{1}{2}[F''(x - vt) + F''^*(x - vt)]$$

is applied to the boundary $y = 0$. (F^* denotes the complex conjugate of the complex function F , and F'' denotes the second derivative.)

25. A solid sphere performs small radial pulsations in air of density ρ so that its radius at time t is $R + \alpha \sin pt$. Show that the velocity potential of the sound waves produced is

$$\phi = \frac{\alpha p R^2}{v \sqrt{1 + (pR/c)^2}} \frac{\cos \{p[t - (r - R)/c] - \gamma\}}{r}$$

where c is the velocity of sound in air and $\tan \gamma = pR/c$, and that the approximate average rate at which the sphere loses energy to the air is

$$\frac{2\pi\alpha c^3 \alpha^2 (pR/c)^4}{1 + (pR/c)^2}$$

26. The radius of a sphere at time t is $a(1 + \epsilon \cos \omega t)$, where ϵ is small. Show that to the first order in ϵ the pressure amplitude of the sound waves is

$$\frac{\rho_0 \alpha^2 c a^3 \epsilon}{r \sqrt{c^2 + \omega^2 a^2}}$$

at a distance r from the center of the sphere.

27. Air is contained inside a spherical shell of radius a , and there is a point source of sound, of strength $A \cos \sigma t$, at the center. The acute angle α is defined by the equation $\tan \alpha = ka$, where $k = \sigma/c$. Show that the velocity potential inside the sphere is

$$\frac{A}{4\pi r} \cos \sigma t \frac{\sin(ka - \alpha - kr)}{\sin(ka - \alpha)}$$

provided that $ka - \alpha$ is not an integral multiple of π . What is the significance of this condition?

28. Prove that a particular solution of the wave equation is

$$C \cos \theta \frac{\partial}{\partial r} \left\{ \frac{1}{r} f(nt - kr) \right\}$$

where n is a real constant and $k = n/c$.

A sound wave is produced by the small vibrations of a rigid sphere of radius a which is moving so that its center moves along the line $\theta = 0$ with velocity $U \cos(nt)$. Determine the velocity potential, and show that at a great distance from the sphere the radial velocity of the fluid is approximately

$$-\frac{k^2 a^3 U}{r \sqrt{4 + k^4 a^4}} \cos \theta \cos(nt - kr - ka - \phi)$$

where $\tan \phi = 2ka/(2 - k^2 a^2)$.

29. A uniform elastic sphere of radius a and density ρ is vibrating radially under no external forces. The radial displacement u satisfies the equation

$$(\lambda + 2\mu) \left(\frac{\partial^2 u}{\partial r^2} - \frac{2}{r} \frac{\partial u}{\partial r} - \frac{2u}{r^2} \right) = \rho \frac{\partial^2 u}{\partial t^2}$$

where λ and μ are elastic constants, and the radial component of stress is

$$\sigma_r = (\lambda + 2\mu) \frac{\partial u}{\partial r} - 2\lambda \frac{u}{r}$$

Prove that the periods of the normal modes of vibration are $2\pi a/c_1 \xi$, where $c_1^2 = (\lambda + 2\mu)/\rho$ and the ξ 's are the positive roots of the transcendental equation

$$4\xi \cot \xi = 4 - \beta^2 \xi^2$$

in which $\beta^2 = (\lambda + 2\mu)/\mu$.

30. Monochromatic sound waves of velocity potential $\Psi_0(\mathbf{r})e^{i\lambda ct}$ are incident on the positive side of a screen in the xy plane which has a small aperture S_1 at the origin. The boundary condition is the vanishing of the total wave function on the screen. The dimensions of the aperture are small compared with the wavelength $2\pi/k$ of the incident wave. Show that at a great distance r from the aperture on the negative side of the screen the velocity potential is given approximately by

$$\psi(r, t) = A \frac{\partial}{\partial z} \left\{ \frac{e^{-i\lambda(r-ct)}}{r} \right\}$$

$$\text{where } A = \frac{1}{2\pi} \int_{S_1} f(x', y') dx' dy'$$

and the function $f(x, y)$ is such that the function

$$\Psi_0 = \frac{1}{2\pi} \int_{S_1} \frac{f(x', y') dx' dy'}{\sqrt{(x-x')^2 + (y-y')^2}}$$

vanishes on the boundary of S_1 and satisfies on S_1 the equation

$$\nabla^2 \Psi_0 + C = 0$$

where C is the value of $\partial \Psi_0 / \partial z$ at the origin.

If S_1 is a circular disk of radius a and center 0, verify that

$$f(x, y) = \frac{2C}{\pi} \sqrt{a^2 - x^2 - y^2}$$

and that

$$\Psi(r, t) = -\frac{2ikCa^2z}{3\pi r^2} e^{-i\lambda(r-ct)}$$

31. Monochromatic sound waves of velocity potential $\Psi_0(x, y)e^{i\lambda ct}$ are incident on the positive side of an infinite perfectly reflecting screen lying in the plane $y = 0$ which contains apertures bounded by straight lines parallel to the z axis so that the apertures cut the plane $z = 0$ in a set of straight lines L_1 lying on the x axis. Show that if $y > 0$, the total velocity potential is given by

$$\Psi(x, y) = \Psi_0(x, y) + \Psi_0(x, -y) + \frac{1}{2}i \int_{L_1} f(x') H_0^{(2)}(k\rho) dx'$$

where $\rho = \sqrt{(x-x')^2 + y^2}$ and $f(x)$ satisfies the integral equation

$$\int_{L_1} f(x') H_0^{(2)}(k|x'-x|) dx = 2i\Psi_0(x, 0)$$

where the point $(x, 0, 0)$ belongs to L_1 .

Deduce the solution for $y < 0$.

32. If, in the last problem, the material of the screen instead of being perfectly reflecting had been such that the total velocity potential vanished on it, show that the velocity potential is given everywhere by

$$\Psi(x, y) = \Psi_1(x, y) + \frac{1}{2}i \int_{L_2} f(x') H_0^{(2)}(k\rho) dx'$$

where L_2 is the set of lines on the x axis in which the screen cuts the plane $z = 0$, $\rho = \sqrt{(x - x')^2 + y^2}$, and $f(x)$ satisfies the integral equation

$$\int_{L_2} f(x') H_0^{(2)}(k|x' - x|) dx' = 2i\Psi_1(x, 0)$$

where the point $(x, 0)$ belongs to L_2 .

33. Show that if \mathbf{E} and \mathbf{H} satisfy Maxwell's equations

$$\operatorname{div} \mathbf{E} = 0, \quad \operatorname{div} \mathbf{H} = 0$$

$$\operatorname{curl} \mathbf{E} = -\frac{\mu}{c} \frac{\partial \mathbf{H}}{\partial t}, \quad \operatorname{curl} \mathbf{H} = \frac{\epsilon}{c} \frac{\partial \mathbf{E}}{\partial t}$$

for a medium of dielectric constant ϵ and permeability μ , then

$$\left(\nabla^2 - \frac{1}{v^2} \frac{\partial^2}{\partial t^2} \right) (\mathbf{E}, \mathbf{H}) = 0$$

where $v^2 = c^2 / \epsilon \mu$.

Deduce that

$$\mathbf{E} = \mathbf{e}_1 e^{iR_1} + \mathbf{e}_2 e^{iR_2}, \quad \mathbf{H} = \sqrt{\frac{\epsilon}{\mu}} \{ (\mathbf{n} \times \mathbf{e}_1) e^{iR_1} - (\mathbf{n} \times \mathbf{e}_2) e^{iR_2} \}$$

is a solution with $R_1 = \rho[t - (\mathbf{n} \cdot \mathbf{r})/v]$, $R_2 = \rho[t + (\mathbf{n} \cdot \mathbf{r})/v]$, and the vectors $\mathbf{e}_1, \mathbf{e}_2, \mathbf{n}$ constant vectors. Prove that

$$\mathbf{H} = \mathbf{h}_1 e^{iR_1} - \mathbf{h}_2 e^{iR_2}, \quad \mathbf{E} = -\sqrt{\frac{\mu}{\epsilon}} \{ (\mathbf{n} \times \mathbf{h}_1) e^{iR_1} - (\mathbf{n} \times \mathbf{h}_2) e^{iR_2} \}$$

is also a solution of Maxwell's equations.

34. The electric force in a plane electromagnetic wave *in vacuo* has the components

$$E_x = 0, \quad E_y = a \cos p \left\{ t - \frac{x \sin \alpha + z \cos \alpha}{c} \right\}, \quad E_z = 0$$

Find the magnetic force.

The wave is incident on the plane face of a uniform dielectric, in which the dielectric constant is ϵ and the magnetic permeability is unity, occupying the region $z \geq 0$. Find the amplitude of the reflected wave.¹

35. The magnetic force in a plane electromagnetic wave *in vacuo* has the components

$$H_x = a \cos p \left\{ t - \frac{y \sin \alpha + z \cos \alpha}{c} \right\}, \quad H_y = H_z = 0$$

Find the electric force.

¹ The boundary conditions are that the normal components of $\epsilon \mathbf{E}$ and $\mu \mathbf{H}$ are continuous and that the tangential components of \mathbf{E} and \mathbf{H} are continuous.

The wave is incident on the plane face of a uniform dielectric, in which the dielectric constant is ϵ and the magnetic permeability is unity, occupying the region $z > 0$. Find the amplitude of the reflected wave, and show in particular that it vanishes if the angle of incidence α is $\tan^{-1} \epsilon^{1/2}$.

36. Prove that a possible electromagnetic field in *vacuo* is given by

$$\mathbf{E} = -\frac{1}{c} \text{curl}(\dot{\theta}\mathbf{k}), \quad \mathbf{H} = \text{grad}(\mathbf{k} \cdot \text{grad} \theta) - \frac{j\mathbf{k}}{c^2}$$

where \mathbf{k} is a constant vector and θ is a scalar function of position and time which satisfies the wave equation $\nabla^2\theta = \ddot{\theta}/c^2$.

Taking \mathbf{k} to be the unit vector in the direction of the z axis of a rectangular coordinate system and θ to be of the form $\theta = f(x, y, z - at)$, where a is a positive constant, prove that the rate of transmission of energy across an area S which lies in a plane $z = \text{constant}$ can be expressed in the form

$$\frac{a}{4\pi} \int_S \left\{ \left(\frac{\partial^2 f}{\partial x \partial z} \right)^2 + \left(\frac{\partial^2 f}{\partial y \partial z} \right)^2 \right\} dx dy$$

Show also that $\mathbf{E} \cdot \mathbf{H} = 0$ and $\mathbf{E} \cdot \mathbf{k} = 0$ whatever the value of a but that $\mathbf{H} \cdot \mathbf{k} = 0$ only if $a = c$.

37. Establish the existence of an electromagnetic field of the form

$$E_x = \frac{\partial u}{\partial y}, \quad E_y = -\frac{\partial u}{\partial x}, \quad E_z = 0$$

$$H_x = 0, \quad H_y = 0, \quad H_z = \frac{1}{c} \frac{\partial u}{\partial t}$$

where $u = \exp(-iky - ickt)f(r - y)$, ($r^2 = x^2 + y^2$) and determine the functions $f(r - y)$.

38. Show that if $\mathbf{\Pi}$ is a vector function of space and time coordinates which at a fixed position in space is proportional to $\exp(ickt)$ (k constant) and which satisfies the equation

$$\nabla^2 \mathbf{\Pi} - k^2 \mathbf{\Pi} = 0$$

then the electric and magnetic fields

$$\mathbf{E} = -ik \text{curl} \mathbf{\Pi} \quad \text{and} \quad \mathbf{H} = \text{curl} \text{curl} \mathbf{\Pi}$$

satisfy Maxwell's equations for free space.

By considering the case in which the direction of $\mathbf{\Pi}$ is uniform and its magnitude is spherically symmetrical, show that a nonzero simple harmonic electromagnetic field of period $2\pi/(ck)$ can exist in a sphere of radius a with perfectly conducting walls if ka satisfies the equation

$$\tan ka = ka$$

39. Show that in cylindrical coordinates ρ, θ, z Maxwell's equations for empty space have a solution

$$H_\rho = 0, \quad H_\theta = \frac{1}{c} \frac{\partial^2 f}{\partial \rho \partial t}, \quad H_z = 0$$

$$E_\rho = -\frac{\partial^2 f}{\partial \rho \partial z}, \quad E_\theta = \frac{1}{\rho} \frac{\partial}{\partial \rho} \left(\rho \frac{\partial f}{\partial \rho} \right)$$

and find the differential equation satisfied by f .

40. Show that there is a solution of Maxwell's equations for electromagnetic waves *in vacuo* in which the components of the magnetic intensity are

$$H_x = \frac{\partial^2 S}{\partial y \partial t}, \quad H_y = \frac{\partial^2 S}{\partial x \partial t}, \quad H_z = 0$$

where $rS = f(ct - r)$, r is the distance from the origin, c the speed of light, and f an arbitrary function.

Obtain the corresponding formulas for the components of the electric intensity, and prove that the lines of electric force are the meridian curves of the surfaces

$$\rho \frac{\partial S}{\partial \rho} = \text{const.}$$

where

$$\rho = (x^2 + y^2)^{\frac{1}{2}}$$

41. Prove that Maxwell's equations

$$\text{curl } \mathbf{E} = \frac{1}{c} \frac{\partial \mathbf{H}}{\partial t} = 0, \quad \text{div } [\mu^2(r)\mathbf{E}] = 0$$

$$\text{curl } \mathbf{H} = \frac{\mu^2(r)}{c} \frac{\partial \mathbf{E}}{\partial t} = 0, \quad \text{div } \mathbf{H} = 0$$

for an inhomogeneous spherically symmetrical medium of index of refraction $\mu(r)$ have solutions

$$(a) \quad \mathbf{E} = \frac{1}{\mu^2} e^{-ikr} \text{curl curl } (\mathbf{r}\mu f), \quad \mathbf{H} = -ike^{-ikr} \text{curl } (\mathbf{r}\mu f)$$

where f satisfies the scalar wave equation

$$\nabla^2 f = \left\{ k^2 \mu^2 - \mu \frac{d^2}{dr^2} \left(\frac{1}{\mu} \right) \right\} f = 0$$

$$(b) \quad \mathbf{E} = \frac{ik}{\mu^2} \text{curl } (\mathbf{r}\mu^2 g), \quad \mathbf{H} = \text{curl } \frac{\text{curl } (\mathbf{r}\mu^2 g)}{\mu^2}$$

where g satisfies the scalar wave equation

$$\nabla^2 g = k^2 \mu^2 g = 0$$

42. A scalar wave function ψ satisfies the wave equation

$$\nabla^2 \psi = \frac{\mu^2}{c^2} \frac{\partial^2 \psi}{\partial t^2}$$

where μ , the refractive index, is a function of x, y, z . We define a wave front as any continuously moving surface that contains discontinuities of ψ and assume the existence of one wave front only. Taking ψ_1, ψ_2 to be the wave function on either side of the wave front and writing

$$\psi^* = \psi_1 - \psi_2, \quad \psi = \psi_1 H(\phi) + \psi_2 H(-\phi)$$

where $H(\phi)$ denotes Heaviside's unit function defined to be 1 for $\phi > 0$ and 0 for $\phi < 0$, prove Bremmer's relations

$$(a) \quad |\text{grad } S| = \pm \mu$$

$$(b) \quad \psi^* \nabla^2 S + 2(\text{grad } S \cdot \text{grad } \psi^*) + \frac{2\mu^2}{c} \frac{\partial \psi^*}{\partial t} = 0$$

Denoting differentiating along the normals to the surfaces $S = \text{constant}$ by $\partial/\partial n$, show that the variation of any function f in the ray direction is given by

$$\frac{df}{dn} = \frac{1}{\mu} (\text{grad } f \cdot \text{grad } S)$$

Hence prove that (b) can be written in the form

$$2\mu \frac{d}{dn} (\log \psi^*) = -\nabla^2 S$$

and that the change of ψ^* along a trajectory is related to that of μ and that of the cross section σ of a small beam according to the relation

$$\mu\sigma\psi^{*2} = \text{const.}$$

43. The electric and magnetic vectors \mathbf{E} and \mathbf{H} satisfy Maxwell's equations

$$\text{curl } \mathbf{H} = \frac{1}{c} \frac{\partial}{\partial t} (\epsilon \mathbf{E}) + \frac{4\pi\sigma}{c} \mathbf{E} = \frac{1}{c} \frac{\partial \mathbf{F}}{\partial t}$$

$$\text{curl } \mathbf{E} = -\frac{1}{c} \frac{\partial}{\partial t} (\mu \mathbf{H}) = 0$$

$$\text{div} \left(\frac{\partial}{\partial t} (\epsilon \mathbf{E}) + 4\pi\sigma \mathbf{E} \right) = -\frac{\partial}{\partial t} \text{div } \mathbf{F}$$

$$\text{div } (\mu \mathbf{H}) = 0$$

where $(1/4\pi)(\partial \mathbf{F}/\partial t)$ represents the enforced current density and σ , ϵ , and μ may be any functions of x , y , z , and t . If $\mathbf{V}^* = \mathbf{V}_1 - \mathbf{V}_2$ represents the jump of V on the wave fronts $\phi = 0$, show that

$$\mathbf{H}^* \times \text{grad } \phi = -\frac{1}{c} \{(\epsilon \mathbf{E})^* - \mathbf{F}^*\} \frac{\partial \phi}{\partial t}$$

$$\mathbf{E}^* \cdot \text{grad } \phi = -\frac{1}{c} (\mu \mathbf{H})^* \frac{\partial \phi}{\partial t}$$

$$\left(\left(\frac{\partial(\epsilon \mathbf{E})}{\partial t} \right)^* + 4\pi(\sigma \mathbf{E})^* - \left(\frac{\partial \mathbf{F}}{\partial t} \right)^* \right) \cdot \text{grad } \phi = 0$$

$$(\mu \mathbf{H})^* \cdot \text{grad } \phi = 0$$

Chapter 6

THE DIFFUSION EQUATION

In this last chapter we shall consider the typical parabolic equation

$$k \frac{\partial^2 \theta}{\partial x^2} = \frac{\partial \theta}{\partial t}$$

and its generalizations to two and three dimensions. Because of its occurrence in the analysis of diffusion phenomena we shall refer to this equation as the *one-dimensional diffusion equation* and to its generalization

$$k \nabla^2 \theta = \frac{\partial \theta}{\partial t}$$

(where k is a constant) as the *diffusion equation*.

We shall illustrate the theory of these equations mainly by reference to the theory of the conduction of heat in solids, but we shall begin by outlining other circumstances in which the solution of such equations is of importance.

1. The Occurrence of the Diffusion Equation in Physics

We have already seen in Sec. 2 of Chap. 3 how the one-dimensional wave equation arises in the theory of the transmission of electric signals along a cable. We shall now indicate further instances of the occurrence of diffusion equations in theoretical physics.

(a) *The Conduction of Heat in Solids.* If we denote by θ the temperature at a point in a homogeneous isotropic solid, then it is readily shown that the rate of flow of heat per unit area across any plane is

$$q = -k \frac{\partial \theta}{\partial n} \quad (1)$$

where k is the *thermal conductivity* of the solid and the operator $\partial/\partial n$ denotes differentiation along the normal. Considering the flow of heat through a small element of volume, we can show that the variation of θ is governed by the equation

$$\rho c \frac{\partial \theta}{\partial t} = \text{div} (k \text{ grad } \theta) + H(\mathbf{r}, \theta, t) \quad (2)$$

where ρ is the density and c the specific heat of the solid, and $H(\mathbf{r}, \theta, t) d\tau$ is the amount of heat generated per unit time in the element $d\tau$ situated at the point with position vector \mathbf{r} .

The heat function $H(\mathbf{r}, \theta, t)$ may arise because the solid is undergoing radioactive decay or is absorbing radiation. A term of this kind exists also when there is generation or absorption of heat in the solid as a result of a chemical reaction, e.g., the hydration of cement.

If the conductivity k is a constant throughout the body, and if we write

$$\kappa = \frac{k}{\rho c}, \quad Q(\mathbf{r}, \theta, t) = \frac{H(\mathbf{r}, \theta, t)}{\rho c}$$

equation (2) reduces to the form

$$\frac{\partial \theta}{\partial t} = \kappa \nabla^2 \theta + Q(\mathbf{r}, \theta, t) \quad (3)$$

The fundamental problem of the mathematical theory of the conduction of heat is the solution of equation (2) when it is known that the boundary surfaces of the solid are treated in a prescribed manner. The boundary conditions are usually of three main types:¹

- (i) The temperature is prescribed all over the boundary; i.e., the temperature $\theta(\mathbf{r}, t)$ is a prescribed function of t for every point \mathbf{r} of the bounding surface;
- (ii) The flux of heat across the boundary is prescribed; i.e., $\partial \theta / \partial n$ is prescribed;
- (iii) There is radiation from the surface into a medium of fixed temperature θ_0 ; i.e.,

$$\frac{\partial \theta}{\partial n} + h(\theta - \theta_0) = 0 \quad (4)$$

where h is a constant.

If we introduce the differential operator

$$\lambda = C_0 + C_1 \frac{\partial}{\partial x} + C_2 \frac{\partial}{\partial y} + C_3 \frac{\partial}{\partial z} \quad (5)$$

where C_0, C_1, C_2, C_3 are functions of x, y, z only, we see that the general boundary condition

$$\lambda \theta(\mathbf{r}, t) = G(\mathbf{r}, t) \quad \mathbf{r} \in S \quad (6)$$

embraces all three cases.

(b) *Diffusion in Isotropic Substances.* Another example of the occurrence of the diffusion equation arises in the analysis of the process of diffusion in physical chemistry. This is a process leading to the

¹ For the discussion of more complicated types of boundary conditions see H. S. Carslaw and J. C. Jaeger, "Conduction of Heat in Solids" (Oxford, New York, 1947).

equalization of concentrations within a single phase, and it is governed by laws connecting the rate of flow of the diffusing substance with the concentration gradient causing the flow.¹ If c is the concentration of the diffusion substance, then the diffusion current vector \mathbf{J} is given by Fink's first law of diffusion in the form

$$\mathbf{J} = -D \text{grad } c \quad (7)$$

where D is the coefficient of diffusion for the substance under consideration. The equation of continuity for the diffusing substance takes the form

$$\frac{\partial c}{\partial t} + \text{div } \mathbf{J} = 0 \quad (8)$$

Substituting from equation (7) into equation (8), we find that the variation of the concentration is governed by the equation

$$\frac{\partial c}{\partial t} = \text{div } (D \text{grad } c) \quad (9)$$

In the most general case the coefficient of diffusion D will depend on the concentration and the coordinates of the point in question. If, however, D does happen to be a constant, then equation (9) reduces to the form

$$\frac{\partial c}{\partial t} = D \nabla^2 c \quad (10)$$

(c) *The Slowing Down of Neutrons in Matter.* Under certain circumstances² the one-dimensional transport equations governing the slowing down of neutrons in matter can be reduced to the form

$$\frac{\partial \chi}{\partial \theta} = \frac{\partial^2 \chi}{\partial z^2} + T(z, \theta) \quad (11)$$

where θ is the "symbolic age" and $\chi(z, \theta)$ is the number of neutrons per unit time which reach the age θ ; i.e., χ is the *slowing-down density*. The function T is related to $S(z, u)$, the number of neutrons being produced per unit time and per unit volume, by the relation

$$T(z, \theta) = 4\pi S(z, u) \frac{du}{d\theta} \quad (12)$$

where $u = \log(E_0/E)$ is a dimensionless parameter expressing the energy E of the neutron in terms of a standard energy E_0 .

(d) *The Diffusion of Vorticity.* In the case of a viscous fluid of

¹ For a thorough discussion of particular cases the reader is referred to W. Jost, "Diffusion in Solids, Liquids, Gases" (Academic Press, New York, 1952).

² See I. N. Sneddon, "Fourier Transforms" (McGraw-Hill, New York, 1951), p. 212.

density ρ and coefficient of viscosity μ which is started into motion from rest the vorticity ζ , which is related to the velocity \mathbf{q} in the fluid by the equation

$$\zeta = \text{curl } \mathbf{q} \quad (13)$$

is governed by the diffusion equation

$$\frac{\partial \zeta}{\partial t} = \nu \nabla^2 \zeta \quad (14)$$

where $\nu = \mu/\rho$ is the kinematic viscosity.

(e) *Conducting Media.* Maxwell's equations for the electromagnetic field in a medium of conductivity σ , permeability μ , and dielectric constant κ may be written in the form

$$\text{div } (\kappa \mathbf{E}) = 0$$

$$\text{div } (\mu \mathbf{H}) = 0$$

$$\text{curl } \mathbf{H} = \frac{4\pi\sigma}{c} \mathbf{E} + \frac{1}{c} \frac{\partial}{\partial t} (\kappa \mathbf{E})$$

$$\text{curl } \mathbf{E} = -\frac{1}{c} \frac{\partial}{\partial t} (\mu \mathbf{H})$$

If we make use of the identity

$$\text{curl curl} = \text{grad div} - \nabla^2$$

then it follows from these equations that when σ , μ , κ are constant throughout the medium

$$\nabla^2 \mathbf{E} = \frac{\kappa\mu}{c^2} \frac{\partial^2 \mathbf{E}}{\partial t^2} + \frac{4\pi\sigma\mu}{c^2} \frac{\partial \mathbf{E}}{\partial t}$$

If we are dealing with problems concerning the propagation of long waves in a good conductor, the first term on the right-hand side of this equation may be neglected in comparison with the second. We therefore find that the components of the vector \mathbf{E} satisfy the equation

$$\nabla^2 \theta = \frac{1}{v} \frac{\partial \theta}{\partial t} \quad (15)$$

where $v = c^2/(4\pi\mu\sigma)$.

PROBLEMS

1. Suppose that the diffusion is linear with boundary conditions $c = c_1$ at $x = 0$, $c = c_2$ at $x = l$ and that the diffusion coefficient D is given by a formula of the type $D = D_0[1 - f(c)]$, where D_0 is a constant. Show that if the concentration distribution for the steady state has been measured, the function $f(c)$ can be determined by means of the relation

$$l[c + F(c) - c_1 - F(c_1)] = x[c_2 - F(c_2) - c_1 - F(c_1)]$$

where

$$F(c) = \int_0^c f(u) du$$

Show further that if v is the quantity of solute passing per unit area during time t , then

$$D_0 = \frac{vt}{t[c_1 - F(c_1) - c_2 + F(c_2)]}$$

2. Show that diffusion in a linear infinite system in which the diffusion coefficient D depends on the concentration c is governed by the equation

$$\frac{\partial c}{\partial t} = D \frac{\partial^2 c}{\partial x^2} = \frac{dD}{dc} \left(\frac{\partial c}{\partial x} \right)^2$$

If initially $c = c_0$ for $x = 0$ and $c = 0$ for $x = \infty$, and if c is measured as a function of x and t , show that the variation of D with c may be determined by means of the equation

$$D(c) = -\frac{1}{2} \frac{d\xi}{dc} \int_{c_0}^c \xi dc$$

where $\xi = xt^{-1/2}$.

3. Show that the equation

$$\frac{\partial \theta}{\partial t} = \kappa \nabla^2 \theta + \psi(t)\theta + \phi(\mathbf{r}, t)$$

may be reduced to the form

$$\frac{\partial u}{\partial t} = \kappa \nabla^2 u + \chi(\mathbf{r}, t)$$

by the substitutions

$$u = \theta \exp \left\{ - \int_0^t \psi(t') dt' \right\}, \quad \chi(\mathbf{r}, t) = \phi(\mathbf{r}, t) \exp \left\{ - \int_0^t \psi(t') dt' \right\}$$

2. The Resolution of Boundary Value Problems for the Diffusion Equation

We shall now describe a method due to Bartels and Churchill¹ for the resolution of complicated boundary problems for the generalized diffusion equation.

If we assume that the function $H(\mathbf{r}, \theta, t)$ occurring in equation (2) of the last section is a linear function of the temperature θ of the form

$$H(\mathbf{r}, \theta, t) = \rho c [C_0(\mathbf{r})\theta + F(\mathbf{r}, t)] \quad (1)$$

where C_0 is a function of \mathbf{r} only, introducing the linear differential operator

$$\Lambda = \frac{1}{\rho c} \operatorname{div} (k \operatorname{grad}) + C_0(\mathbf{r}) \quad (2)$$

and denoting by \mathbf{r} the position vector of a point in the solid and by \mathbf{r}' that of a point on its boundary, it follows from equations (2) and (6)

¹ R. C. F. Bartels and R. V. Churchill, *Bull. Am. Math. Soc.*, **48**, 276 (1942). See also Sneddon, *op. cit.*, pp. 162-166.

of the last section that the boundary value problem for the temperature $\theta(\mathbf{r}, t)$ in the solid can be written in the form

$$\begin{aligned}\frac{\partial}{\partial t} \theta(\mathbf{r}, t) &= \Delta \theta + F(\mathbf{r}, t) & t > 0 \\ \lambda \theta(\mathbf{r}', t) &= G(\mathbf{r}', t) & t > 0 \\ \theta(\mathbf{r}, 0) &= J(\mathbf{r})\end{aligned}\tag{A}$$

The third equation of this set merely expresses the fact that at the instant $t = 0$ the distribution of temperature throughout the solid is prescribed.

We shall now show that the complicated boundary value problem (A) may be resolved into simpler problems.

Suppose that the function $\phi(\mathbf{r}, t, t')$ depending on the fixed parameter t' is a solution of the boundary value problem (A) in the case in which the source function F and the surface temperature G are functions of the space variables and of the parameter t' but not of the time t , so that $\phi(\mathbf{r}, t, t')$ satisfies the equations

$$\begin{aligned}\frac{\partial}{\partial t} \phi(\mathbf{r}, t, t') &= \Delta \phi + F(\mathbf{r}, t') \\ \lambda \phi(\mathbf{r}, t, t') &= G(\mathbf{r}', t') \\ \phi(\mathbf{r}, 0, t') &= J(\mathbf{r})\end{aligned}\tag{B}$$

Then it is readily shown that once the solution of the boundary value problem (B) is known, the solution of the boundary value (A) can be derived by a simple calculation. The method is contained in:

Theorem 1: Duhamel's Theorem. *The solution $\theta(\mathbf{r}, t)$ of the boundary value problem (A) with time-dependent source and surface conditions is given in terms of the solution $\phi(\mathbf{r}, t, t')$ of the boundary value problem (B) with constant source and surface conditions by the formula*

$$\theta(\mathbf{r}, t) = \frac{\partial}{\partial t} \int_0^t \phi(\mathbf{r}, t - t', t') dt'$$

We shall give in outline a direct proof of Duhamel's theorem. For an ingenious proof making use of the theory of Laplace transforms the reader is referred to the paper by Bartels and Churchill mentioned above.

If the boundary condition is

$$\lambda \theta(\mathbf{r}', t) = \begin{cases} 0 & t > 0 \\ G(\mathbf{r}', t) & t < 0 \end{cases}$$

it follows that the corresponding solution of (A) is

$$\theta = \phi(\mathbf{r}, t, t') \quad t > 0$$

Similarly if the boundary condition is

$$\lambda\theta(\mathbf{r}', t) = \begin{cases} 0 & t < t' \\ G(\mathbf{r}', t') & t > t' \end{cases}$$

the corresponding temperature is

$$\theta = \phi(\mathbf{r}, t - t', t') \quad t > t'$$

Further if

$$\lambda\theta(\mathbf{r}', t) = \begin{cases} 0 & t < t' + dt' \\ G(\mathbf{r}', t') & t > t' + dt' \end{cases}$$

then $\theta = \phi(\mathbf{r}', t - t' - dt', t')$ $t > t' + dt'$

and it follows that if the boundary condition is

$$\lambda\theta(\mathbf{r}', t) = \begin{cases} 0 & t < t' \\ G(\mathbf{r}', t') & t' < t < t' + dt' \\ 0 & t > t' + dt' \end{cases}$$

the solution of the boundary value problem is

$$\begin{aligned} \theta &= \phi(\mathbf{r}, t - t', t') - \phi(\mathbf{r}, t - t' - dt', t') \\ &= dt' \frac{\partial \phi(\mathbf{r}, t - t', t')}{\partial t} \end{aligned}$$

By breaking up the interval $t = 0$ to $t = t$ into small intervals in this way and integrating the results obtained we find that the solution of the boundary value problem (A) is

$$\theta(\mathbf{r}, t) = \frac{\partial}{\partial t} \int_0^t \phi(\mathbf{r}, t - t', t') dt' \quad (3)$$

This theorem is of great value in the solution of boundary value problems in the theory of the conduction of heat, since it is often easier to derive the solution in the case of constant source and boundary conditions.

It can further be shown that the solution of the boundary value problem (B) can be written in the form

$$\phi(\mathbf{r}, t, t') = \phi_1(\mathbf{r}, t') + \phi_2(\mathbf{r}, t, t') + \int_0^t \phi_3(\mathbf{r}, \tau, t') d\tau \quad (4)$$

where the functions ϕ_1 , ϕ_2 , and ϕ_3 are solutions of the boundary value problems

$$\Lambda\phi_1(\mathbf{r}, t') = 0, \quad \lambda\phi_1(\mathbf{r}', t') = G(\mathbf{r}', t') \quad (B_1)$$

$$\left(\frac{\partial}{\partial t} - \Lambda\right)\phi_2(\mathbf{r}, t, t') = 0, \quad \lambda\phi_2(\mathbf{r}', t, t') = 0, \quad \phi_2(\mathbf{r}, 0, t') = J(\mathbf{r}) - \phi_1(\mathbf{r}, t') \quad (B_2)$$

$$\left(\frac{\partial}{\partial t} - \Lambda\right)\phi_3(\mathbf{r}, t, t') = 0, \quad \lambda\phi_3(\mathbf{r}', t, t') = 0, \quad \phi_3(\mathbf{r}, 0, t') = F(\mathbf{r}, t') \quad (B_3)$$

From Duhamel's theorem it follows that the solution of the boundary value problem is

$$\theta(\mathbf{r}, t) = \phi_1(\mathbf{r}, t) - \frac{\hat{c}}{\hat{c}t} \int_0^t \phi_2(\mathbf{r}, t - t', t') dt' - \int_0^t \phi_3(\mathbf{r}, t - t', t') dt' \quad (5)$$

The solutions of the three simpler boundary value problems (B₁), (B₂), and (B₃), of which the first is a steady-state problem, may therefore be used to derive the solution of the general boundary value problem (A).

PROBLEMS

1. If $\theta_r(x_r, t)$ $r = 1, 2, 3$ is the solution of the one-dimensional diffusion equation

$$\frac{\partial^2 \theta_r}{\partial x_r^2} = \frac{1}{\kappa} \frac{\partial \theta_r}{\partial t} \quad a_r < x_r < b_r, t > 0$$

satisfying the initial condition $\theta_r(x_r, 0) = f_r(x_r)$ and the boundary conditions

$$\alpha_r \frac{\partial \theta_r}{\partial x_r} - \alpha'_r \theta_r = 0, \quad x_r = a_r \quad t > 0$$

$$\beta_r \frac{\partial \theta_r}{\partial x_r} - \beta'_r \theta_r = 0, \quad x_r = b_r \quad t > 0$$

then the solution of

$$\frac{\partial^2 \theta}{\partial x_1^2} + \frac{\partial^2 \theta}{\partial x_2^2} + \frac{\partial^2 \theta}{\partial x_3^2} = \frac{1}{\kappa} \frac{\partial \theta}{\partial t}$$

in the rectangular parallelepiped $a_1 < x_1 < b_1, a_2 < x_2 < b_2, a_3 < x_3 < b_3$ satisfying the boundary conditions

$$\alpha_r \frac{\partial \theta}{\partial x_r} - \alpha'_r \theta = 0, \quad x_r = a_r \quad t > 0, r = 1, 2, 3,$$

$$\beta_r \frac{\partial \theta}{\partial x_r} - \beta'_r \theta = 0, \quad x_r = b_r \quad t > 0, r = 1, 2, 3$$

and the initial condition $\theta = f_1(x_1)f_2(x_2)f_3(x_3)$ is

$$\theta(x_1, x_2, x_3, t) = \theta_1(x_1, t)\theta_2(x_2, t)\theta_3(x_3, t)$$

2. If $R(r, t)$ is the solution of the boundary value problem

$$\frac{1}{r} \frac{\partial}{\partial r} \left(r \frac{\partial R}{\partial r} \right) = \frac{1}{\kappa} \frac{\partial R}{\partial t} \quad t > 0, a < r < b$$

$$\alpha_1 \frac{\partial R}{\partial r} - \alpha'_1 R, r = a; \quad \beta_1 \frac{\partial R}{\partial r} - \beta'_1 R, r = b; \quad R(r, 0) = f(r)$$

and if $Z(z, t)$ is the solution of the boundary value problem

$$\frac{\partial^2 Z}{\partial z^2} = \frac{1}{\kappa} \frac{\partial Z}{\partial t}, \quad t > 0, c < z < d$$

$$\alpha_2 \frac{\partial Z}{\partial z} - \alpha'_2 Z, z = c; \quad \beta_2 \frac{\partial Z}{\partial z} - \beta'_2 Z, z = d; \quad Z(z, 0) = g(z)$$

then

$$\theta(r, z, t) = R(r, t)Z(z, t)$$

is the solution of the boundary value problem

$$\frac{1}{r} \frac{\partial}{\partial r} \left(r \frac{\partial \theta}{\partial r} \right) + \frac{\partial^2 \theta}{\partial z^2} = \frac{1}{\kappa} \frac{\partial \theta}{\partial t} \quad a < r < b, c < z < d, t > 0$$

satisfying the initial condition $\theta = f(r)g(z)$ and the boundary conditions

$$\begin{aligned} \alpha_1 \frac{\partial \theta}{\partial r} &= \alpha'_1 \theta, r = a; & \beta_1 \frac{\partial \theta}{\partial r} &= \beta'_1 \theta, r = b \\ \alpha_2 \frac{\partial \theta}{\partial z} &= \alpha'_2 \theta, z = c; & \beta_2 \frac{\partial \theta}{\partial z} &= \beta'_2 \theta, z = d \end{aligned}$$

3. Elementary Solutions of the Diffusion Equation

In this section we shall consider elementary solutions of the one-dimensional diffusion equation

$$\frac{\partial^2 \theta}{\partial x^2} = \frac{1}{\kappa} \frac{\partial \theta}{\partial t} \quad (1)$$

We begin by considering the expression

$$\theta = \frac{1}{\sqrt{t}} \exp \left(-\frac{x^2}{4\kappa t} \right) \quad (2)$$

For this function it is readily seen that

$$\frac{\partial^2 \theta}{\partial x^2} = \frac{x^2}{4\kappa^2 t^{3/2}} e^{-x^2/4\kappa t} - \frac{1}{2\kappa t^{3/2}} e^{-x^2/4\kappa t}$$

and

$$\frac{\partial \theta}{\partial t} = \frac{x^2}{4\kappa t^{5/2}} e^{-x^2/4\kappa t} - \frac{1}{2t^{3/2}} e^{-x^2/4\kappa t}$$

showing that the function (2) is a solution of the equation (1).

It follows immediately that

$$\frac{1}{2\sqrt{\pi\kappa t}} e^{-(x-\xi)^2/4\kappa t} \quad (3)$$

where ξ is an arbitrary real constant, is also a solution. Furthermore, if the function $\phi(x)$ is bounded for all real values of x , then it is possible that the integral

$$\frac{1}{2\sqrt{\pi\kappa t}} \int_{-\infty}^{\infty} \phi(\xi) \exp \left\{ -\frac{(x-\xi)^2}{4\kappa t} \right\} d\xi \quad (4)$$

is also, in some sense, a solution of the equation (1).

It may readily be proved that the integral (4) is convergent if $t > 0$ and that the integrals obtained from it by differentiating under the integral sign with respect to x and t are uniformly convergent in the neighborhood of the point (x, t) . The function $\theta(x, t)$ and its derivatives of all orders therefore exist for $t > 0$, and since the integrand satisfies

the one-dimensional diffusion equation, it follows that $\theta(x,t)$ itself satisfies that equation for $t > 0$.

Now

$$\left| \frac{1}{2(\pi\kappa t)^{1/2}} \int_{-\infty}^{\infty} \phi(\xi) \exp \left\{ -\frac{(x - \xi)^2}{4\kappa t} \right\} d\xi - \phi(x) \right|$$

$$= |I_1 + I_2 + I_3 + I_4|$$

where

$$I_1 = \frac{1}{\sqrt{\pi}} \int_{-N}^N \{\phi(x + 2u\sqrt{\kappa t}) - \phi(x)\} e^{-u^2} du$$

$$I_2 = \frac{1}{\sqrt{\pi}} \int_N^{\infty} \phi(x + 2u\sqrt{\kappa t}) e^{-u^2} du$$

$$I_3 = \frac{1}{\sqrt{\pi}} \int_{-\infty}^{-N} \phi(x + 2u\sqrt{\kappa t}) e^{-u^2} du$$

$$I_4 = \frac{2\phi(x)}{\sqrt{\pi}} \int_N^{\infty} e^{-u^2} du$$

If the function $\phi(x)$ is bounded, we can make each of the integrals I_2, I_3, I_4 as small as we please by taking N to be sufficiently large, and by the continuity of the function ϕ we can make the integral I_1 as small as we please by taking t sufficiently small. Thus as $t \rightarrow 0, \theta(x,t) \rightarrow \phi(x)$. Thus the Poisson integral

$$\theta(x,t) = \frac{1}{2(\pi\kappa t)^{1/2}} \int_{-\infty}^{\infty} \phi(\xi) \exp \left\{ -\frac{(x - \xi)^2}{4\kappa t} \right\} d\xi \tag{5}$$

is the solution of the initial value problem

$$\frac{\partial^2 \theta}{\partial x^2} = \frac{1}{\kappa} \frac{\partial \theta}{\partial t} \quad -\infty < x < \infty \tag{6}$$

$$\theta(x,0) = \phi(x)$$

It will be observed that by a simple change of variable we can express the solution (5) in the form

$$\theta(x,t) = \frac{1}{\sqrt{\pi}} \int_{-\infty}^{\infty} \phi(x + 2u\sqrt{\kappa t}) e^{-u^2} du \tag{7}$$

We shall now show how this solution may be modified to obtain the solution of the boundary value problem

$$\frac{\partial^2 \theta}{\partial x^2} = \frac{1}{\kappa} \frac{\partial \theta}{\partial t} \quad 0 \leq x < \infty$$

$$\theta(x,0) = f(x) \quad x > 0 \tag{8}$$

$$\theta(0,t) = 0 \quad t > 0$$

If we write

$$\phi(x) = \begin{cases} f(x) & \text{for } x > 0 \\ -f(-x) & \text{for } x < 0 \end{cases}$$

then the Poisson integral (4) assumes the form

$$\theta(x,t) = \frac{1}{2\sqrt{\pi\kappa t}} \int_0^\infty f(\xi) \{e^{-(x-\xi)^2/4\kappa t} - e^{-(x+\xi)^2/4\kappa t}\} d\xi \quad (9)$$

and it is readily verified that this is the solution of the boundary value problem (8). We may express the solution (9) in the form

$$\begin{aligned} \theta(x,t) = & \frac{1}{\sqrt{\pi}} \int_{-x/2\sqrt{\kappa t}}^\infty f(x+2u\sqrt{\kappa t})e^{-u^2} du \\ & - \frac{1}{\sqrt{\pi}} \int_{x/2\sqrt{\kappa t}}^\infty f(-x+2u\sqrt{\kappa t})e^{-u^2} du \end{aligned} \quad (10)$$

Thus if the initial temperature is a constant, θ_0 say, then

$$\theta(x,t) = \theta_0 \operatorname{erf} \left(\frac{x}{2\sqrt{\kappa t}} \right) \quad (11)$$

where

$$\operatorname{erf} z = \frac{2}{\sqrt{\pi}} \int_0^z e^{-u^2} du \quad (12)$$

The function

$$\theta(x,t) = \theta_0 \left[1 - \operatorname{erf} \left(\frac{x}{2\sqrt{\kappa t}} \right) \right] \quad (13)$$

will therefore have the property that $\theta(x,0) = 0$. Furthermore $\theta(0,t) = \theta_0$. Thus the function

$$\theta(x,t,t') = g(t') \left[1 - \operatorname{erf} \left(\frac{x}{2\sqrt{\kappa t'}} \right) \right]$$

is the function which satisfies the one-dimensional diffusion equation and the conditions $\theta(x,0,t') = 0$, $\theta(0,t,t') = g(t')$. By applying Duhamel's theorem it follows that the solution of the boundary value problem

$$\theta(x,0) = 0, \quad \theta(0,t) = g(t) \quad (14)$$

is

$$\begin{aligned} \theta(x,t) &= \frac{2}{\sqrt{\pi}} \frac{\partial}{\partial t} \int_0^t g(t') dt' \int_{x/2\sqrt{\kappa t} - \sqrt{\kappa t'}}^\infty e^{-u^2} du \\ &= \frac{x}{2\sqrt{\pi\kappa}} \int_0^t g(t') \frac{e^{-x^2/4\kappa(t-t')}}{(t-t')^{3/2}} dt' \end{aligned}$$

Changing the variable of integration from t' to u where

$$t' = t - \frac{x^2}{4\kappa u^2}$$

we see that the solution may be written in the form

$$\theta(x,t) = \frac{2}{\sqrt{\pi}} \int_{\eta}^{\infty} g\left(t - \frac{x^2}{4\kappa u^2}\right) e^{-u^2} du, \quad \eta = \frac{x}{2\sqrt{\kappa t}} \quad (15)$$

PROBLEMS

1. The surface $x = 0$ of the semi-infinite solid $x \geq 0$ is kept at temperature θ_0 during $0 < t \leq T$ and is maintained at zero temperature for $t > T$. Show that if $t > T$,

$$\theta(x,t) = \theta_0 \left\{ \operatorname{erf} \frac{x}{2\sqrt{\kappa(t-T)}} - \operatorname{erf} \frac{x}{2\sqrt{\kappa t}} \right\}$$

and determine the value of θ if $t < T$.

2. Prove that the expression¹

$$\theta(\mathbf{r},t) = \frac{Q}{8(\pi\kappa)^{3/2}} \exp\left\{-\frac{|\mathbf{r}-\mathbf{a}|^2}{4\kappa t}\right\}$$

represents the temperature in an infinite solid due to a quantity of heat $Q\rho c$ instantaneously generated at $t = 0$ at a point with position vector \mathbf{a} .

If heat is liberated at the point \mathbf{a} in an infinite solid at a rate $\rho c f(t)$ per unit time in the interval $(0,t)$, show that the temperature in the solid is given by

$$\frac{1}{8(\pi\kappa)^{3/2}} \int_0^t \exp\left\{-\frac{|\mathbf{r}-\mathbf{a}|^2}{4\kappa(t-t')}\right\} \frac{f(t') dt'}{(t-t')^{3/2}}$$

If $f(t) = q$, a constant, show that

$$\theta(\mathbf{r},t) = \frac{q}{4\pi\kappa|\mathbf{r}-\mathbf{a}|} \left\{ 1 - \operatorname{erf} \frac{|\mathbf{r}-\mathbf{a}|}{\sqrt{4\kappa t}} \right\}$$

3. Show that the temperature due to an instantaneous line source of strength Q at $t = 0$ parallel to the z axis and passing through the point (a,b) is

$$\theta(x,y,t) = \frac{Q}{4\pi\kappa t} \exp\left\{-\frac{(x-a)^2 + (y-b)^2}{4\kappa t}\right\}$$

If heat is liberated at the rate $\rho c f(t)$ per unit time per unit length of a line through the point (a,b) parallel to the z axis, and if the supply of heat starts at $t = 0$ when the solid is at zero temperature, show that if $t > 0$,

$$\theta(x,y,t) = \frac{1}{4\pi\kappa} \int_0^t f(t') \exp\left\{-\frac{r^2}{4\kappa(t-t')}\right\} \frac{dt'}{t-t'}$$

where $r^2 = (x-a)^2 + (y-b)^2$.

Deduce that if $f(t) = q$, a constant,

$$\theta(x,y,t) = -\frac{q}{4\pi\kappa} \operatorname{Ei}\left(-\frac{r^2}{4\kappa t}\right)$$

where $-\operatorname{Ei}(-x) = \int_x^{\infty} e^{-u} du/u$.

¹ This is called the temperature due to an *instantaneous point source* of strength Q at \mathbf{a} at time $t = 0$.

4. Separation of Variables

The method of the separation of variables can be applied to the diffusion equation

$$\nabla^2 \theta = \frac{1}{\kappa} \frac{\partial \theta}{\partial t} \quad (1)$$

in a manner similar to those employed in the similar problems of potential theory and wave motion. If we assume that the time and space variables can be separated, so that equation (1) has solutions of the form

$$\theta = \phi(\mathbf{r})T(t) \quad (2)$$

then it follows from the fact that equation (1) can be written in the form

$$\frac{1}{\phi} \nabla^2 \phi = \frac{1}{\kappa T} \frac{dT}{dt}$$

that the equations determining the functions T and ϕ must be of the forms

$$\frac{dT}{dt} + \kappa \lambda^2 T = 0 \quad (3)$$

$$(\nabla^2 + \lambda^2)\phi = 0 \quad (4)$$

where λ is a constant which may be complex. Since the solution of (3) is immediate, we see that solutions of (1) of the type (2) assume the form

$$\theta(\mathbf{r}, t) = \phi(\mathbf{r})e^{-\kappa \lambda^2 t} \quad (5)$$

where the function ϕ is a solution of the Helmholtz equation (4), which may itself be solved by the method of separation of variables.

We have already used this method in Sec. 9 of Chap. 3 to obtain solutions of the one-dimensional diffusion equation

$$\frac{\partial^2 \theta}{\partial x^2} = \frac{1}{\kappa} \frac{\partial \theta}{\partial t} \quad (6)$$

of the form

$$\theta(x, t) = \sum_{\lambda} [c_{\lambda} \cos(\lambda x) + d_{\lambda} \sin(\lambda x)] e^{-\lambda^2 \kappa t} \quad (7)$$

where c_{λ} and d_{λ} are constants.

We shall now consider the use of this form in the solution of a typical boundary value problem.

Example 1. The faces $x = 0$, $x = a$ of an infinite slab are maintained at zero temperature. The initial distribution of temperature in the slab is described by the equation $\theta = f(x)$ ($0 \leq x \leq a$). Determine the temperature at a subsequent time t .

Our problem is to find a function $\theta(x, t)$ which satisfies the differential equation (6) and the conditions

$$\theta(0, t) = \theta(a, t) = 0, \quad \theta(x, 0) = f(x) \quad (8)$$

In order that a solution of the type (7) should vanish identically at $x = 0$, we must choose $c_\lambda = 0$ for all values of λ , and in order that $\theta(a, t) = 0$, we must choose λ so that

$$\sin(\lambda a) = 0$$

i.e., λ must be taken to be of the form $n\pi/a$, where n is an integer. Hence the first two of the three conditions (8) are satisfied if we take

$$\theta(x, t) = \sum_{n=1}^{\infty} A_n \sin\left(\frac{n\pi x}{a}\right) e^{-n^2\pi^2\kappa t/a^2}$$

To satisfy the third conditions we must choose the constants A_n in such a way that

$$f(x) = \sum_{n=1}^{\infty} A_n \sin\frac{n\pi x}{a} \quad 0 \leq x \leq a$$

The coefficients A_n must therefore be taken to be

$$A_n = \frac{2}{a} \int_0^a f(u) \sin\frac{n\pi u}{a} du$$

and the required solution is

$$\theta(x, t) = \frac{2}{a} \sum_{n=1}^{\infty} e^{-n^2\pi^2\kappa t/a^2} \sin\left(\frac{n\pi x}{a}\right) \int_0^a f(u) \sin\left(\frac{n\pi u}{a}\right) du \quad (9)$$

The solution

$$\theta(x, y, t) = \sum_{\lambda} \sum_{\mu} c_{\lambda\mu} \cos(\lambda x + \varepsilon_\lambda) \cos(\mu y + \varepsilon_\mu) e^{-(\lambda^2 + \mu^2)\kappa t} \quad (10)$$

of the two-dimensional equation

$$\frac{\partial^2\theta}{\partial x^2} + \frac{\partial^2\theta}{\partial y^2} = \frac{1}{\kappa} \frac{\partial\theta}{\partial t} \quad (11)$$

which we derived in Sec. 9 of Chap. 3 may be treated in a precisely similar way (cf. Prob. 3 below).

If we assume a solution of the form

$$\theta = R(\rho)\Phi(\phi)Z(z)T(t)$$

of the diffusion equation

$$\frac{\partial^2\theta}{\partial \rho^2} + \frac{1}{\rho} \frac{\partial\theta}{\partial \rho} + \frac{1}{\rho^2} \frac{\partial^2\theta}{\partial \phi^2} + \frac{\partial^2\theta}{\partial z^2} = \frac{1}{\kappa} \frac{\partial\theta}{\partial t} \quad (12)$$

we find that T satisfies equation (3) and that R, Φ, Z satisfy equations of the form

$$\begin{aligned} \frac{d^2R}{d\rho^2} + \frac{1}{\rho} \frac{dR}{d\rho} + \left(\lambda^2 + \mu^2 - \frac{\gamma^2}{\rho^2}\right) R &= 0 \\ \frac{d^2Z}{dz^2} = \mu^2 Z, \quad \frac{d^2\Phi}{d\phi^2} + \gamma^2\Phi &= 0 \end{aligned}$$

so that the equation (12) has solutions of the form

$$\sum_{\lambda, \mu, \nu} A_{\lambda \mu \nu} J_0(\sqrt{\lambda^2 + \mu^2} \rho) e^{-\nu z - \lambda^2 \kappa t - i \nu \phi} \tag{13}$$

To illustrate the use of solutions of this kind we consider:

Example 2. Determine the temperature $\theta(\rho, t)$ in the infinite cylinder $0 \leq \rho \leq a$ when the initial temperature is $\theta(\rho, 0) = f(\rho)$ and the surface $\rho = a$ is maintained at zero temperature.

In this instance the solution (13) reduces to the much simpler form

$$\theta(\rho, t) = \sum_{\lambda} A_{\lambda} J_0(\lambda \rho) e^{-\lambda^2 \kappa t} \tag{14}$$

In order that $\theta(a, t) = 0$, the constants λ must be chosen so that $J_0(\lambda a) = 0$; i.e., λ takes the values $\xi_1, \xi_2, \dots, \xi_n, \dots$, the roots of the equations

$$J_0(\xi_n a) = 0 \tag{15}$$

We therefore have

$$\theta(\rho, t) = \sum_n A_n J_0(\rho \xi_n) e^{-\kappa t \xi_n^2} \tag{16}$$

To satisfy the condition $\theta(\rho, 0) = f(\rho)$ the constants A_n must be chosen so that

$$f(\rho) = \sum_n A_n J_0(\rho \xi_n)$$

It follows from the theory of Bessel functions¹ that

$$A_n = \frac{2}{a^2 [J_1(\xi_n a)]^2} \int_0^a u f(u) J_0(\xi_n u) du$$

Substituting this expression into equation (16), we find that the required solution is

$$\theta(\rho, t) = \frac{2}{a^2} \sum_n \frac{J_0(\xi_n \rho)}{[J_1(\xi_n a)]^2} e^{-\kappa t \xi_n^2} \int_0^a u f(u) J_0(\xi_n u) du \tag{17}$$

where the sum is taken over the positive roots $\xi_1, \xi_2, \dots, \xi_n, \dots$, of the equation (15).

Finally if we write the diffusion equation

$$\kappa \nabla^2 \psi = \frac{\partial \psi}{\partial t}$$

in polar coordinates (r, θ, ϕ) and assume a solution of the form

$$\psi = R(r)\Theta(\theta)\Phi(\phi)e^{-\lambda^2 \kappa t}$$

we find that

$$\begin{aligned} \frac{d^2 R}{dr^2} + \frac{2}{r} \frac{dR}{dr} + \left\{ \lambda^2 - \frac{n(n+1)}{r^2} \right\} R &= 0 \\ (1 - \mu^2) \frac{d^2 \Theta}{d\mu^2} - 2\mu \frac{d\Theta}{d\mu} + \left\{ n(n+1) - \frac{m^2}{1 - \mu^2} \right\} \Theta &= 0 \quad \mu = \cos \theta \\ \frac{d^2 \Phi}{d\phi^2} + m^2 \Phi &= 0 \end{aligned}$$

¹ G. N. Watson, "The Theory of Bessel Functions," 2d ed. (Cambridge, London, 1944), chap. XVIII.

so that we have solutions of the form

$$\sum_{m,n,\lambda} C_{mn\lambda} (\lambda r)^{-\frac{1}{2}} J_{n+\frac{1}{2}}(\lambda r) P_n^m(\cos \theta) e^{-i m \theta} e^{-\lambda^2 \kappa t} \tag{18}$$

This solution is used in:

Example 3. Find the temperature in a sphere of radius a when its surface is maintained at zero temperature and its initial temperature is $f(r, \theta)$.

In order that a solution of the type (18), i.e.,

$$\sum_{n,\lambda} C_{n\lambda} (\lambda r)^{-\frac{1}{2}} J_{n+\frac{1}{2}}(\lambda r) P_n(\cos \theta) e^{-\lambda^2 \kappa t} \tag{19}$$

should vanish when $r = a$, each λ must be chosen to be one of the roots $\lambda_{n1}, \lambda_{n2}, \dots, \lambda_{ni}, \dots$ of the equations

$$J_{n+\frac{1}{2}}(\lambda a) = 0 \tag{20}$$

and in order that $\psi(r, \theta + 2\pi, t) = \psi(r, \theta, t)$, n must be an integer. We therefore have the solution

$$\psi(r, \theta, t) = \sum_{n=1}^{\infty} \sum_{i=1}^{\infty} C_{ni} (\lambda_{ni} r)^{-\frac{1}{2}} J_{n+\frac{1}{2}}(\lambda_{ni} r) P_n(\cos \theta) e^{-\lambda_{ni}^2 \kappa t}$$

where the constants C_{ni} must be chosen so that

$$f(r, \theta) = \sum_{n=1}^{\infty} \sum_{i=1}^{\infty} C_{ni} (\lambda_{ni} r)^{-\frac{1}{2}} J_{n+\frac{1}{2}}(\lambda_{ni} r) P_n(\cos \theta)$$

From the theory of Bessel functions and Legendre polynomials we find that

$$C_{ni} = \frac{(2n+1)\lambda_{ni}^{\frac{1}{2}}}{a^2 [J'_{n+\frac{1}{2}}(\lambda_{ni} a)]^2} \int_0^a r^{\frac{1}{2}} J_{n+\frac{1}{2}}(r\lambda_{ni}) dr \int_{-1}^1 P_n(\mu) f(r, \theta) d\mu$$

PROBLEMS

1. Solve the one-dimensional diffusion equation in the region $0 \leq x \leq \pi$, $t \geq 0$, when
 - (i) θ remains finite as $t \rightarrow \infty$;
 - (ii) $\theta = 0$ if $x = 0$ or π , for all values of t ;
 - (iii) At $t = 0$, $\begin{cases} \theta = x & 0 \leq x \leq \frac{1}{2}\pi \\ \theta = \pi - x & \frac{1}{2}\pi \leq x \leq \pi. \end{cases}$

2. Solve the one-dimensional diffusion equation in the range $0 \leq x \leq 2\pi$, $t \geq 0$ subject to the boundary conditions

$$\begin{aligned} \theta(x, 0) &= \sin^3 x & \text{for } 0 \leq x \leq 2\pi \\ \theta(0, t) &= \theta(2\pi, t) = 0 & \text{for } t \geq 0 \end{aligned}$$

3. The edges $x = 0, a$ and $y = b$ of the rectangle $0 \leq x \leq a, 0 \leq y \leq b$ are maintained at zero temperature while the temperature along the edge $y = 0$ is made to vary according to the rule $\theta(x, 0, t) = f(x)$, $0 \leq x \leq a, t > 0$. If the initial temperature in the rectangle is zero, find the temperature at any subsequent time t , and deduce that the steady-state temperature is

$$\frac{2}{a} \sum_{m=1}^{\infty} \frac{\sinh [m\pi(b-y)/a]}{\sinh (m\pi b/a)} \sin \left(\frac{m\pi x}{a} \right) \int_0^a f(u) \sin \left(\frac{m\pi u}{a} \right) du$$

4. A circular cylinder of radius a has its surface kept at a constant temperature θ_0 . If the initial temperature is zero throughout the cylinder, prove that for $t > 0$

$$\theta(r, t) = \theta_0 \left\{ 1 - \frac{2}{a} \sum_{n=1}^{\infty} \frac{J_0(\xi_n a)}{\xi_n J_1(\xi_n a)} e^{-\xi_n^2 \kappa t} \right\}$$

where $-\xi_1, -\xi_0, \dots, -\xi_n, \dots$ are the roots of $J_0(\xi a) = 0$.

5. The Use of Integral Transforms

We shall now consider the application of the theory of the integral transforms to the solution of diffusion problems. First of all we shall indicate the use of the Laplace transform. Suppose that we have to find a function $\theta(\mathbf{r}, t)$ which satisfies the diffusion equation

$$\nabla^2 \theta = \frac{1}{\kappa} \frac{\partial \theta}{\partial t} \quad (1)$$

in the region bounded by the two surfaces S_1 and S_2 , the initial condition

$$\theta = f(\mathbf{r}) \quad \text{when } t = 0 \quad (2)$$

and the boundary conditions

$$a_1 \theta + b_1 \frac{\partial \theta}{\partial n} = g_1(\mathbf{r}, t) \quad \text{on } S_1 \quad (3)$$

$$a_2 \theta + b_2 \frac{\partial \theta}{\partial n} = g_2(\mathbf{r}, t) \quad \text{on } S_2 \quad (4)$$

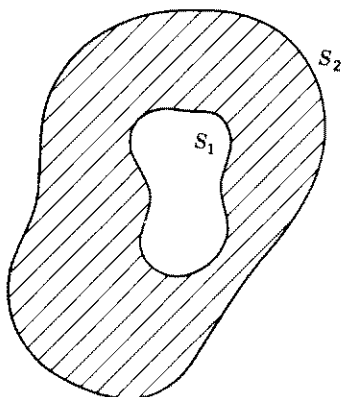

Figure 46

where the functions f , g_1 , and g_2 are prescribed. The quantities a_1 , a_2 , b_1 , b_2 may be functions of x , y , and z , but we shall assume that they do not depend on t .

To solve this system of equations we introduce the Laplace transform $\bar{\theta}(\mathbf{r}, s)$ of the function $\theta(\mathbf{r}, t)$ defined by the equation

$$\bar{\theta}(\mathbf{r}, s) = \int_0^{\infty} \theta(\mathbf{r}, t) e^{-st} dt$$

If we make use of the rule for integrating by parts, we find that

$$\int_0^{\infty} \frac{\partial \theta}{\partial t} e^{-st} dt = [\theta(\mathbf{r}, t) e^{-st}]_0^{\infty} + s \bar{\theta}(\mathbf{r}, s)$$

Substituting from (2) into this expression, we find on multiplying both sides of equation (1) by e^{-st} and integrating with respect to t from 0 to ∞ that $\bar{\theta}(\mathbf{r}, s)$ satisfies the nonhomogeneous Helmholtz equation

$$(\nabla^2 - k^2) \bar{\theta}(\mathbf{r}, s) = \frac{1}{\kappa} f(\mathbf{r}) \quad (5)$$

with $k^2 = s/\kappa$. Similarly the boundary conditions (3) and (4) can be shown to be equivalent to

$$a_1 \bar{\theta} + b_1 \frac{\partial \bar{\theta}}{\partial n} = \bar{g}_1(\mathbf{r}, s) \quad \text{on } S_1 \quad (6)$$

$$a_2 \bar{\theta} + b_2 \frac{\partial \bar{\theta}}{\partial n} = \bar{g}_2(\mathbf{r}, s) \quad \text{on } S_2 \quad (7)$$

The method is particularly appropriate when equation (5) can readily be reduced to an ordinary differential equation, as in the case considered below. When the function $\bar{\theta}(\mathbf{r}, s)$, which forms the solution of the boundary value problem expressed by the equations (5), (6), and (7), has been determined, the temperature $\theta(\mathbf{r}, t)$ is given by Laplace's inversion formula

$$\theta(\mathbf{r}, t) = \frac{1}{2\pi i} \int_{c-i\infty}^{c+i\infty} \bar{\theta}(\mathbf{r}, s) e^{st} ds \quad (8)$$

In the case where the solid body is bounded by one surface only, S_1 say, we only have an equation of type (3), but we have in addition the condition that θ , and hence $\bar{\theta}$, does not become infinite within S_1 .

Example 4. Determine the function $\theta(r, t)$ satisfying

$$\frac{\partial^2 \theta}{\partial r^2} + \frac{1}{r} \frac{\partial \theta}{\partial r} = \frac{1}{\kappa} \frac{\partial \theta}{\partial t} \quad t > 0, 0 < r < a \quad (9)$$

and the conditions $\theta(r, 0) = 0$, $\theta(a, t) = f(t)$.

To solve equation (9) we multiply both sides by e^{-st} and integrate with respect to t from 0 to ∞ . Making use of the conditions $\bar{\theta}(r, 0) = 0$, we see that

$$\frac{d^2 \bar{\theta}}{dr^2} + \frac{1}{r} \frac{d\bar{\theta}}{dr} - \frac{s}{\kappa} \bar{\theta} = 0 \quad (10)$$

where $\bar{\theta}(r, s)$ is the Laplace transform of $\theta(r, t)$. Since $\theta(a, t) = f(t)$, it follows that

$$\bar{\theta} = \bar{f}(s) \quad \text{on } r = a \quad (11)$$

where $\bar{f}(s)$ is the Laplace transform of the function $f(t)$. If we make use of the physical condition that $\theta(r, t)$, and, hence, $\bar{\theta}(r, s)$, cannot be infinite along the axis $r = 0$ of the cylinder, we see that the solution of equation (10) appropriate to the boundary condition (11) is

$$\bar{\theta}(r, s) = \bar{f}(s) \frac{I_0(kr)}{I_0(ka)}$$

where $k^2 = s/\kappa$, so that, by the result (8),

$$\theta(r, t) = \frac{1}{2\pi i} \int_{c-i\infty}^{c+i\infty} \bar{f}(s) \frac{I_0(kr)}{I_0(ka)} e^{st} ds$$

Now if $I_0(kr)/I_0(ka)$ is the Laplace transform of the function $g(t)$, i.e., if

$$g(t) = \frac{1}{2\pi i} \int_{c-i\infty}^{c+i\infty} \frac{I_0(kr)}{I_0(ka)} e^{st} ds \quad (12)$$

it is readily shown that

$$\theta(r, t) = \int_0^t f(t') g(t - t') dt' \quad (13)$$

To evaluate the contour integral (12) we note that the integrand is a single-valued function of s , so that we may make use of the contour shown in Fig. 47. The poles of the integrand are at the points

$$s = s_n = -\kappa \xi_n^2 \quad n = 1, 2, \dots$$

where the quantities $\xi_1, \xi_2, \dots, \xi_n, \dots$ are the roots of the transcendental equation

$$J_0(a\xi) = 0 \tag{14}$$

From the theory of Bessel functions we know that the roots of equation (14) are all real and simple. If we take the radius of the circle MNL to be $\kappa(n - \frac{1}{2})^2 \pi^2 / a^2$, there will be no poles of the integrand on the circumference of the circle, and from the asymptotic expansions of the modified Bessel functions $I_0(kr), I_0(ka)$ it is readily shown that the integral round the circular arc MNL tends to the value 0 as $n \rightarrow \infty$. We may therefore replace the line integral for $g(t)$ by the integral of the same function taken round the complete contour of Fig. 47, and hence we may replace it by the sum of the residues of the function $I_0(kr)e^{st}/I_0(ka)$ in the plane $\Re(s) < c$. Now the residue of this function at the pole $s = s_n$ is

$$\frac{I_0(ir\xi_n)e^{-\kappa\xi_n^2 t}}{a(2i\kappa\xi_n)I_1(ia\xi_n)} = \frac{2\kappa\xi_n J_0(r\xi_n)e^{-\kappa\xi_n^2 t}}{aJ_1(a\xi_n)}$$

since $I_1(x) = I_0'(x)$. Hence we have

$$g(t) = \sum_{n=1}^{\infty} \frac{2\kappa\xi_n J_0(r\xi_n)}{aJ_1(a\xi_n)} e^{-\kappa\xi_n^2 t} \tag{15}$$

Substituting from equation (15) into equation (13), we obtain finally

$$\theta(r,t) = \frac{2\kappa}{a} \sum_{n=1}^{\infty} \frac{\xi_n J_0(r\xi_n)}{J_1(a\xi_n)} \int_0^t f(t') e^{-\kappa\xi_n^2(t-t')} dt' \tag{16}$$

where the sum is taken over the positive roots of the transcendental equation (14).

We shall give a further example of the use of Laplace transforms at the end of the next section.

Other integral transforms may be used in a similar way. To illustrate the use of Fourier transforms in the solution of three-dimensional diffusion problems we consider:

Example 5. Find the solution of the equation

$$\kappa \nabla^2 \theta = \frac{\partial \theta}{\partial t} \tag{17}$$

for an infinite solid whose initial distribution of temperature is given by

$$\theta(r,0) = f(r) \tag{18}$$

where the function f is prescribed.

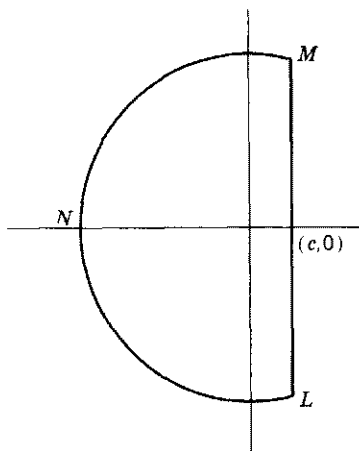

Figure 47

We reduce the equation (17) to an ordinary differential equation by the introduction of the Fourier transform of the function $\theta(\mathbf{r}, t)$ defined by the equation

$$\Theta(\boldsymbol{\rho}, t) = (2\pi)^{-3} \int \theta(\mathbf{r}, t) e^{i(\boldsymbol{\rho} \cdot \mathbf{r})} d\tau \quad (19)$$

where $\boldsymbol{\rho} = (\xi, \eta, \zeta)$, $d\tau = dx dy dz$, and the integration extends throughout the entire xyz space. Multiplying both sides of equation (17) by $\exp [i(\boldsymbol{\rho} \cdot \mathbf{r})]$ and integrating throughout the entire xyz space, we find, after an integration by parts (in which it is assumed that θ and its space derivatives vanish at great distances from the origin), that equations (17) and (18) are equivalent to the pair of equations

$$\frac{d\Theta}{dt} + \kappa \rho^2 \Theta = 0 \quad (20)$$

$$\Theta(\boldsymbol{\rho}, 0) = F(\boldsymbol{\rho}) \quad (21)$$

where $F(\boldsymbol{\rho})$ is the Fourier transform of the function $f(\mathbf{r})$. The solution of equation (20) subject to the initial condition (21) is

$$\Theta(\boldsymbol{\rho}, t) = F(\boldsymbol{\rho}) e^{-\kappa \rho^2 t} \quad (22)$$

Now it is readily shown by direct integration that the function

$$G(\boldsymbol{\rho}) = e^{-\kappa \rho^2 t} \quad (23)$$

is the Fourier transform of the function

$$g(\mathbf{r}) = (2\kappa t)^{-3/2} e^{-r^2/4\kappa t} \quad (24)$$

and it is a well-known result of the theory of Fourier transforms¹ that if $F(\boldsymbol{\rho})$, $G(\boldsymbol{\rho})$ are the Fourier transforms of $f(\mathbf{r})$, $g(\mathbf{r})$, respectively, then $F(\boldsymbol{\rho})G(\boldsymbol{\rho})$ is the Fourier transform of the function

$$(2\pi)^{-3} \int f(\mathbf{r}') g(\mathbf{r} - \mathbf{r}') d\tau'$$

It follows from equations (22), (23), and (24) that the required solution is

$$\theta(\mathbf{r}, t) = (2\kappa t)^{-3/2} \int f(\mathbf{r}') e^{-|\mathbf{r} - \mathbf{r}'|^2/4\kappa t} d\tau' \quad (25)$$

where the integration extends over the whole $x'y'z'$ space. If we let

$$\mathbf{u} = (u, v, w) = (4\kappa t)^{-1/2} (\mathbf{r}' - \mathbf{r})$$

we find that the solution (25) reduces to the form

$$\theta(\mathbf{r}, t) = \pi^{-3/2} \int_{-\infty}^{\infty} \int_{-\infty}^{\infty} \int_{-\infty}^{\infty} f(\mathbf{r} + 2\mathbf{u}\sqrt{\kappa t}) e^{-(u^2 + v^2 + w^2)} du dv dw \quad (26)$$

which is known as *Fourier's solution*.

PROBLEMS

1. Use the theory of the Laplace transform to derive the solution of the boundary value problem:

$$\frac{\partial^2 \theta}{\partial x^2} = \frac{1}{\kappa} \frac{\partial \theta}{\partial t} \quad 0 \leq x \leq a, \quad t > 0$$

$$\theta(0, t) = f(t), \quad \theta(a, t) = 0, \quad \theta(x, 0) = 0$$

¹ Sneddon, "Fourier Transforms," p. 45.

2. If $\theta(r, t)$ satisfies the equations

$$(i) \quad \frac{\partial^2 \theta}{\partial r^2} - \frac{1}{r} \frac{\partial \theta}{\partial r} - \frac{1}{\kappa} \frac{\partial \theta}{\partial t} = 0 \quad r \leq a, t > 0$$

$$(ii) \quad \theta(r, 0) = f(r) \quad 0 \leq r \leq a$$

$$(iii) \quad \left(\frac{\partial \theta}{\partial r} - h\theta \right)_{r=a} = 0 \quad t > 0$$

show that

$$\theta(r, t) = \frac{2}{a^2} \sum_i \frac{\xi_i^2 e^{-k\xi_i^2 t} J_0(\xi_i r)}{(h^2 + \xi_i^2) [J_0(\xi_i a)]^2} \int_0^a u f(u) J_0(\xi_i u) du$$

where the sum is taken over the positive roots $\xi_1, \xi_2, \dots, \xi_i, \dots$ of the equation

$$hJ_0(a\xi_i) = \xi_i J_1(a\xi_i)$$

3. Using the theory of the Fourier exponential transform to eliminate the x variable from the diffusion equation, derive the solution (5) of Sec. 3.

4. Using the Fourier sine transform

$$\Theta_s(\xi, t) = \left(\frac{2}{\pi} \right)^{1/2} \int_0^\infty \theta(x, t) \sin(\xi x) dx$$

derive the solutions (9) and (13) of Sec. 3.

5. A plane electromagnetic pulse is propagated in the positive z direction in an unbounded medium of constant permeability μ and conductivity σ . At the instant $t = 0$ the electric vector \mathbf{E} is given by

$$E_x = \frac{1}{\delta} \exp\left(-\frac{z^2}{\delta^2}\right), \quad E_y = E_z = 0$$

Determine the value of E_x at a later instant t .

6. The Use of Green's Functions

We saw in Sec. 8 of Chap. 4 how Green's functions may be employed with advantage in the determination of solutions of Laplace's equation. We proceed now to show how a similar function may be used conveniently in the mathematical theory of diffusion processes.

Suppose we are considering the solution $\theta(\mathbf{r}, t)$ of the diffusion equation

$$\frac{\partial \theta}{\partial t} = \kappa \nabla^2 \theta \quad (1)$$

in the volume V , which is bounded by the simple surface S , subject to the boundary condition

$$\theta(\mathbf{r}, t) = \phi(\mathbf{r}, t) \quad \text{if } \mathbf{r} \in S \quad (2)$$

and the initial condition

$$\theta(\mathbf{r}, 0) = f(\mathbf{r}) \quad \text{if } \mathbf{r} \in V \quad (3)$$

We then define the Green's function $G(\mathbf{r}, \mathbf{r}', t - t')$ ($t > t'$) of our problem as the function which satisfies the equation

$$\frac{\partial G}{\partial t} = \kappa \nabla^2 G \quad (4)$$

the boundary condition

$$G(\mathbf{r}, \mathbf{r}', t - t') = 0 \quad \text{if } \mathbf{r}' \in S \quad (5)$$

and the initial condition that $\lim_{t \rightarrow t'} G$ is zero at all points of V except at the point \mathbf{r} where G takes the form

$$\frac{1}{8[\pi\kappa(t - t')]^{\frac{3}{2}}} \exp \left[-\frac{|\mathbf{r} - \mathbf{r}'|^2}{4\kappa(t - t')} \right] \quad (6)$$

Because G depends on t only in that it is a function of $t - t'$, it follows that equation (4) is equivalent to

$$\frac{\partial G}{\partial t'} + \kappa \nabla^2 G = 0 \quad (7)$$

The physical interpretation of the Green's function G is obvious from these equations: $G(\mathbf{r}, \mathbf{r}', t - t')$ is the temperature at \mathbf{r}' at time t due to an instantaneous point source of unit strength generated at time t' at the point \mathbf{r} , the solid being initially at zero temperature, and its surface being maintained at zero temperature.

Since the time t' lies within the interval of t for which equations (1) and (2) are valid, we may rewrite these equations in the form

$$\frac{\partial \theta}{\partial t'} = \kappa \nabla^2 \theta \quad t' < t \quad (8)$$

$$\theta(\mathbf{r}', t') = \phi(\mathbf{r}', t') \quad \text{if } \mathbf{r}' \in S \quad (9)$$

It follows immediately from equations (7) and (8) that

$$\frac{\partial}{\partial t'} (\theta G) = \theta \frac{\partial G}{\partial t'} + G \frac{\partial \theta}{\partial t'} = \kappa [G \nabla^2 \theta - \theta \nabla^2 G]$$

so that if ϵ is an arbitrarily small positive constant,

$$\int_0^{t-\epsilon} \left\{ \int_V \frac{\partial}{\partial t'} (\theta G) d\tau' \right\} dt' = \kappa \int_0^{t-\epsilon} \left\{ \int_V [G \nabla^2 \theta - \theta \nabla^2 G] d\tau' \right\} dt' \quad (10)$$

If we interchange the order in which we take the integrations on the left-hand side, we find that it takes the form

$$\begin{aligned} & \int_V (\theta G)_{t'=t-\epsilon} d\tau' - \int_V (\theta G)_{t'=0} d\tau' \\ &= \theta(\mathbf{r}, t) \int_V [G(\mathbf{r}, \mathbf{r}', t - t')]_{t'=t-\epsilon} d\tau' - \int_V G(\mathbf{r}, \mathbf{r}', t) f(\mathbf{r}') d\tau' \end{aligned}$$

Now from the expression (6) for $G(\mathbf{r}, \mathbf{r}', t - t')$ we can readily show that

$$\int_V [G(\mathbf{r}, \mathbf{r}', t - t')]_{t'=t-\varepsilon} d\tau' = 1$$

so that if we let $\varepsilon \rightarrow 0$, the left-hand side of equation (10) becomes

$$\theta(\mathbf{r}, t) = \int_V f(\mathbf{r}') G(\mathbf{r}, \mathbf{r}', t) d\tau'$$

On the other hand, if we apply Green's theorem to the right-hand side of equation (10) and make use of equations (2) and (5), we find that it reduces to

$$-\kappa \int_0^t dt' \int_S \phi(\mathbf{r}', t) \frac{\partial G}{\partial n} dS'$$

in the limit as $\varepsilon \rightarrow 0$. It will be recalled that $\partial/\partial n$ denotes differentiation along the outward-drawn normal to S . We therefore obtain finally

$$\theta(\mathbf{r}, t) = \int_V f(\mathbf{r}') G(\mathbf{r}, \mathbf{r}', t) d\tau' - \kappa \int_0^t dt' \int_S \phi(\mathbf{r}', t) \frac{\partial G}{\partial n} dS' \quad (11)$$

as the solution of the boundary value problem formulated in equations (1), (2), and (3).

To illustrate the use of a Green's function in a very simple case we consider:

Example 6. *If the surface $z = 0$ of the semi-infinite solid $z \geq 0$ is maintained at temperature $\phi(x, y, t)$ for $t > 0$, and if the initial temperature of the solid is $f(x, y, z)$, determine the distribution of temperature in the solid.*

It is readily shown that the appropriate Green's function for this problem is

$$G(\mathbf{r}, \mathbf{r}', t - t') = \frac{1}{8[\pi\kappa(t - t')]^{\frac{3}{2}}} \left\{ \exp \left[-\frac{|\mathbf{r} - \mathbf{r}'|^2}{4\kappa(t - t')} \right] - \exp \left[-\frac{|\mathbf{r} - \rho'|^2}{4\kappa(t - t')} \right] \right\}$$

where $\rho' = (x', y', -z')$ is the position vector of the image of the point \mathbf{r}' in the plane $z = 0$. For this function

$$\frac{\partial G}{\partial n} = - \left(\frac{\partial G}{\partial z'} \right)_{z'=0} = - \frac{z}{8\pi^{\frac{1}{2}}\kappa^{\frac{3}{2}}(t - t')^{\frac{3}{2}}} \exp \left[-\frac{(x - x')^2 + (y - y')^2 + z^2}{4\kappa(t - t')} \right]$$

so that, from equation (11), we obtain the solution

$$\begin{aligned} \theta(\mathbf{r}, t) &= \frac{1}{8(\pi\kappa t)^{\frac{3}{2}}} \int_V f(\mathbf{r}') [e^{-|\mathbf{r} - \mathbf{r}'|^2/4\kappa t} - e^{-|\mathbf{r} - \rho'|^2/4\kappa t}] d\tau' \\ &- \frac{z}{8(\pi\kappa)^{\frac{3}{2}}} \int_0^t \int_{\text{II}} \frac{\phi(x', y', t')}{(t - t')^{\frac{3}{2}}} \exp \left[-\frac{(x - x')^2 + (y - y')^2 - z^2}{4\kappa(t - t')} \right] dx' dy' dt' \end{aligned}$$

where V denotes the half space $z \geq 0$ and II the entire xy plane.

In this problem we have been able to guess readily the form of the Green's function. For more complicated types of boundary this may not be possible, and so it is desirable to have available a tool for the

determination of the Green's function. The most powerful analytical tool for this purpose is the theory of Laplace transforms. We shall illustrate its use by considering:

Example 7. Determine the Green's function for the thick plate of infinite radius bounded by the parallel planes $z = 0$ and $z = a$.

From equations (4), (5), and (6) we see that we have to determine a function G which vanishes on the planes $z = 0$, $z = a$ and has a singularity of the type (6). We write

$$G(\mathbf{r}, \mathbf{r}', t) = \frac{1}{8[\pi\kappa t]^{\frac{3}{2}}} \exp\left[-\frac{|\mathbf{r} - \mathbf{r}'|^2}{4\kappa t}\right] - G_1(\mathbf{r}, \mathbf{r}', t) \tag{12}$$

where, by virtue of equation (4)

$$\kappa \nabla^2 G_1 = \frac{\partial G_1}{\partial t} \tag{13}$$

If we multiply both sides of equations (12) and (13) by e^{-st} , integrate with respect to t from 0 to ∞ , and make use of the fact that the Laplace transform of

$$\frac{1}{8\pi\kappa t^{\frac{3}{2}}} \exp\left[-\frac{|\mathbf{r} - \mathbf{r}'|^2}{4\kappa t}\right]$$

can be written in the form

$$\frac{1}{4\pi\kappa} \int_0^\infty e^{-\mu|z-z'|} \frac{J_0(\lambda R)}{\mu} \lambda d\lambda$$

where $R^2 = (x - x')^2 + (y - y')^2$ and $\mu^2 = \lambda^2 + s/\kappa$, we find that these equations are equivalent to

$$\bar{G}(\mathbf{r}, \mathbf{r}', s) = \frac{1}{4\pi\kappa} \int_0^\infty e^{-\mu|z-z'|} \frac{J_0(\lambda R)}{\mu} \lambda d\lambda - \bar{G}_1(\mathbf{r}, \mathbf{r}', s) \tag{14}$$

$$\frac{\partial^2 \bar{G}_1}{\partial \rho^2} + \frac{1}{\rho} \frac{\partial \bar{G}_1}{\partial \rho} + \frac{\partial^2 \bar{G}_1}{\partial z^2} + \frac{1}{\rho^2} \frac{\partial^2 \bar{G}_1}{\partial \phi^2} = \frac{s}{\kappa} \bar{G}_1 \tag{15}$$

where \bar{G} , \bar{G}_1 are the Laplace transforms of G , G_1 and, as usual, ρ , z , ϕ denote cylindrical coordinates. Equation (15) has a solution of the form

$$\frac{1}{4\pi\kappa} \int_0^\infty \frac{\lambda}{\mu} J_0(\lambda R) \{F \sinh(\mu z) + H \sinh[\mu(a - z)]\} d\lambda$$

where the functions $F(\lambda)$ and $H(\lambda)$ must be chosen so that \bar{G} vanishes on the planes $z = 0$, $z = a$. We must therefore have

$$F = -e^{-\mu(a-z')} \operatorname{cosech}(\mu a), \quad H = -e^{-\mu z'} \operatorname{cosech}(\mu a)$$

Thus if $0 < z < z'$, we find that

$$\bar{G} = \frac{1}{2\pi\kappa} \int_0^\infty \frac{\lambda J_0(\lambda R) \sinh[\mu(a - z')] \sinh(\mu z)}{\mu \sinh(\mu a)} d\lambda$$

If we make the substitution $\lambda = i\xi$ in this integral, we obtain the form

$$\bar{G} = \frac{1}{4\pi\kappa} \int_{-i\infty}^{i\infty} \frac{\xi J_0(\xi R) \sinh[\eta(a - z')] \sinh(\eta z)}{\eta \sinh(\eta a)} d\xi$$

where $\eta^2 = s/\kappa - \xi^2$. Now it is readily shown by the calculus of residues that

$$\bar{G} = \frac{1}{2\kappa a} \sum_{n=1}^\infty \sin\left(\frac{n\pi z}{a}\right) \sin\left(\frac{n\pi z'}{a}\right) K_0(\xi_n R)$$

where $\xi_n = \sqrt{n^2\pi^2/a^2 + s/\kappa}$. Using the fact that $K_0[x\sqrt{s/\kappa}]$ is the Laplace transform of $(2t)^{-1}e^{-x^2/4\kappa t}$ and that the Laplace transform of $e^{-at}f(t)$ is $\bar{f}(s-a)$, we find that

$$G = \frac{e^{-R^2/a\kappa t}}{2\pi\kappa t a} \sum_{n=1}^{\infty} \sin\left(\frac{n\pi z}{a}\right) \sin\left(\frac{n\pi z'}{a}\right) e^{-n^2\pi^2\kappa t/a^2} \tag{16}$$

This expression could have been obtained by the method of separation of variables if we had been prepared to assume the possibility of the expansion of an arbitrary function in the form (16). One of the advantages of using the theory of the Laplace transform is that it avoids making such an assumption; each Green's function so derived yields an expansion theorem (or an integral theorem).

PROBLEMS

1. Derive the linear analogue of equation (11) for the segment $a \leq x \leq b$. Hence solve the boundary value problem

$$\frac{\partial \theta}{\partial t} - \kappa \frac{\partial^2 \theta}{\partial x^2} \quad x \geq 0, t > 0$$

$$\theta(0, t) = \phi(t), t > 0; \quad \theta(x, 0) = f(x), x \geq 0$$

2. By using the theory of Laplace transforms derive the Green's function for the segment $0 \leq x \leq a$.
3. Show that the Green's function for problems with radial symmetry, in which the temperature vanishes on $r = a$, can be expressed in the form

$$G(r, r', t) = \frac{1}{2\pi a r r'} \sum_{n=1}^{\infty} \sin\left(\frac{n\pi r}{a}\right) \sin\left(\frac{n\pi r'}{a}\right) e^{-n^2\pi^2\kappa t/a^2}$$

4. Show that the two-dimensional analogue of equation (11) is

$$\theta(x, y, t) = \int_S f(x', y') G(x, y; x', y'; t) dS' - \kappa \int_0^t dt' \int_C \phi(x', y'; t') \frac{\partial G}{\partial n} ds'$$

where C is the boundary of the region S , and where G has a singularity of the type

$$\frac{1}{4\pi\kappa t} \exp\left[-\frac{(x-x')^2 + (y-y')^2}{4\kappa t}\right]$$

at the point (x, y) .

Determine the Green's functions for the regions

- (i) $-\infty < x < \infty, y > 0$
- (ii) $x > 0, y > 0$
- (iii) $0 < x < a, 0 < y < b$

5. Show that the Green's function for the cylinder $0 \leq z \leq h, \rho \leq a$ is

$$G(\rho, \phi, z; \rho', \phi', z') = \frac{2}{\pi a^2 h} \sum_{m=1}^{\infty} e^{-m^2\pi^2 h^2 t} \sin\left(\frac{m\pi z}{h}\right) \sin\left(\frac{m\pi z'}{h}\right) \sum_{n=-\infty}^{\infty} \cos n(\phi - \phi') \times \sum_j e^{-\xi_n^2 \kappa t} \frac{J_n(\xi_n \rho) J_n(\xi_n \rho')}{J_n'(\xi_n a)^2}$$

where $\xi_{n1}, \xi_{n2}, \dots, \xi_{ni}, \dots$ are the positive roots of the transcendental equation $J_n(\xi a) = 0$.

7. The Diffusion Equation with Sources

In the previous sections of this chapter we have considered the solution of problems relating to diffusion in a medium in which there are no sources. We shall now consider briefly the solution of the more general equation (3) of Sec. 1 when the source function $Q(\mathbf{r}, \theta, t)$ assumes a simple form. In many cases of practical interest the function $Q(\mathbf{r}, \theta, t)$ may be taken to be a linear function of the temperature of the form

$$Q(\mathbf{r}, \theta, t) = \phi(\mathbf{r}, t) + \theta\psi(t) \quad (1)$$

and we have seen in Prob. 3 of Sec. 1 that the solution of problems of this type can be deduced readily from solutions of the equation

$$\frac{\partial \theta}{\partial t} = \kappa \nabla^2 \theta + \chi(\mathbf{r}, t) \quad (2)$$

We shall consider therefore only this simple equation.

The analysis of problems of this kind can be further simplified. Suppose that we have to solve equation (2) in a region V bounded by a simple surface S subject to the conditions

$$\theta(\mathbf{r}, 0) = f(\mathbf{r}) \text{ if } \mathbf{r} \in V; \quad \theta(\mathbf{r}, t) = \phi(\mathbf{r}, t) \text{ if } \mathbf{r} \in S \quad (3)$$

then if we find a function $\theta_1(\mathbf{r}, t)$ which satisfies the homogeneous equation

$$\frac{\partial \theta}{\partial t} = \kappa \nabla^2 \theta \quad (4)$$

and the boundary and initial conditions (3) and a function $\theta_2(\mathbf{r}, t)$ which satisfies the equation (2) and the boundary and initial conditions

$$\theta_2(\mathbf{r}, 0) = 0 \text{ if } \mathbf{r} \in V; \quad \theta_2(\mathbf{r}, t) = 0 \text{ if } \mathbf{r} \in S \quad (5)$$

then it is immediately obvious that the solution of the problem posed by equations (2) and (3) is given by the equation

$$\theta(\mathbf{r}, t) = \theta_1(\mathbf{r}, t) + \theta_2(\mathbf{r}, t) \quad (6)$$

The methods available for the solution of equation (4) are also available for the solution of the nonhomogeneous equation (2). For instance, if the method of separation of variables has been applied to determine the function $\theta_1(\mathbf{r}, t)$, the same type of expansion may be employed in the determination of $\theta_2(\mathbf{r}, t)$, or if a particular kind of integral transform has been used to find $\theta_1(\mathbf{r}, t)$, it may also be used to determine $\theta_2(\mathbf{r}, t)$.

For instance, if we wish to solve the equation

$$\frac{\partial \theta}{\partial t} = \kappa \frac{\partial^2 \theta}{\partial x^2} + \chi(x, t) \quad (7)$$

in the region $0 \leq x \leq a$, we know that the solution of

$$\frac{\partial \theta}{\partial t} = \kappa \frac{\partial^2 \theta}{\partial x^2}$$

which vanishes when $x = 0$, $x = a$, is of the form

$$\sum_{n=1}^{\infty} A_n e^{-n^2 \pi^2 \kappa t / a^2} \sin \frac{n\pi x}{a}$$

Therefore we assume a solution of equation (7) of the form

$$\theta_2(x, t) = \sum_{n=1}^{\infty} \phi_n(t) \sin \frac{n\pi x}{a} \quad (8)$$

We also employ the expansion

$$\chi(x, t) = \sum_{n=1}^{\infty} \chi_n(t) \sin \frac{n\pi x}{a} \quad (9)$$

where
$$\chi_n(t) = \frac{2}{a} \int_0^a \chi(x, t) \sin \frac{n\pi x}{a} dx \quad (10)$$

Substituting from equations (8) and (9) into equation (7), we see that the functions $\phi_n(t)$ must satisfy the first-order ordinary differential equation

$$\frac{d\phi_n}{dt} + \frac{n^2 \pi^2 \kappa}{a^2} \phi_n = \chi_n(t) \quad (11)$$

and, since $\theta_2(x, 0) = 0$, must also satisfy the initial condition

$$\phi_n(0) = 0 \quad (12)$$

When we have found the functions $\phi_n(t)$ satisfying the equations (11) and (12), we have only to substitute them as coefficients in the expansion (8) to obtain the desired result.

To illustrate this method we consider:

Example 8. *The faces $x = 0$, $x = a$ of a finite slab are maintained at zero temperature. A source of strength Q is situated at $x = b$. Determine the distribution of temperature within the slab.*

We have to solve the equation (7) in which the function $\chi(x, t)$ is $Q(x)$, where

$$Q(x) = \lim_{\epsilon \rightarrow 0} Q_\epsilon(x)$$

where
$$Q_\epsilon(x) = \begin{cases} \frac{Q}{2\epsilon \rho c} & |x - b| < \epsilon \\ 0 & |x - b| > \epsilon \end{cases}$$

The Fourier coefficients of $Q_\epsilon(x)$ are

$$\frac{Q}{\rho c a \epsilon} \int_{b-\epsilon}^{b+\epsilon} \sin \frac{n\pi x}{a} dx = \frac{2Q}{\rho c} \frac{1}{(n\pi\epsilon)} \sin \frac{n\pi\epsilon}{a} \sin \frac{n\pi b}{a}$$

If we let $\epsilon \rightarrow 0$, we find that for this $\chi(x, t)$

$$\chi_n(t) = \frac{2Q}{\rho c a} \sin \frac{n\pi b}{a}$$

Substituting this constant value in equation (11), we see that the approximate form for $\phi_n(t)$ is

$$\phi_n(t) = \frac{2Qa}{\pi^2 k n^2} (1 - e^{-n^2 \pi^2 \kappa t / a^2}) \sin \frac{n\pi b}{a} \tag{13}$$

where, it will be remembered, $k = \rho c \kappa$. Substituting from equation (13) into equation (8), we find that the desired solution is

$$\theta(x,t) = \frac{2Qa}{\pi^2 k} \sum_{n=1}^{\infty} \frac{1}{n^2} (1 - e^{-n^2 \pi^2 \kappa t / a^2}) \sin \frac{n\pi x}{a} \sin \frac{n\pi b}{a}$$

When the range of the space variables is infinite, it is more appropriate to make use of the theory of integral transforms. Consider, for instance, the problem of solving the equation (7) for the infinite range $-\infty < x < \infty$ subject to the initial condition $\theta(x,0) = 0$. If we multiply both sides of equation (7) by $(2\pi)^{-1/2} e^{i\xi x}$ and integrate with respect to x from $-\infty$ to ∞ , we find that the Fourier transform

$$\Theta(\xi,t) = \frac{1}{\sqrt{2\pi}} \int_{-\infty}^{\infty} \theta(x,t) e^{i\xi x} dx \tag{14}$$

satisfies the ordinary differential equation

$$\frac{d\Theta}{dt} + \kappa \xi^2 \Theta = X(\xi,t) \tag{15}$$

where $X(\xi,t)$ denotes the Fourier transform of $\chi(x,t)$. The solution of equation (15) we are seeking must satisfy the initial condition $\Theta(\xi,0) = 0$, so that we have

$$\Theta(\xi,t) = \int_0^t e^{-\kappa \xi^2 (t-t')} X(\xi,t') dt'$$

Making use of Fourier's integral theorem

$$\theta(x,t) = \frac{1}{\sqrt{2\pi}} \int_{-\infty}^{\infty} \Theta(\xi,t) e^{-i\xi x} d\xi$$

and interchanging the order of the integrations, we find that

$$\theta(x,t) = \frac{1}{\sqrt{2\pi}} \int_0^t dt' \int_{-\infty}^{\infty} e^{-i\xi x - \kappa \xi^2 (t-t')} X(\xi,t') d\xi$$

Now

$$F(\xi) = e^{-\kappa \xi^2 (t-t')}$$

is the Fourier transform of the function

$$f(x) = \frac{1}{[2\kappa(t-t')]^{1/2}} e^{-x^2/4\kappa(t-t')}$$

so that using the convolution theorem for Fourier transforms

$$\int_{-\infty}^{\infty} F(\xi)X(\xi)e^{-i\xi x} d\xi = \int_{-\infty}^{\infty} f(x-\eta)\chi(\eta) d\eta$$

we find that

$$\theta(x,t) = \frac{1}{(4\pi\kappa)^{1/2}} \int_0^t \frac{dt'}{(t-t')^{1/2}} \int_{-\infty}^{\infty} e^{-(x-\eta)^2/4\kappa(t-t')} \chi(\eta,t') d\eta$$

is the final solution of our problem.

PROBLEMS

1. The function $\theta(x,t)$ satisfies the equation

$$\frac{\partial\theta}{\partial t} = \kappa \frac{\partial^2\theta}{\partial x^2} + \chi(x,t)$$

for $x \geq 0$, $t > 0$ and $\theta(x,0) = 0$, $\theta(0,t) = 0$. Show that

$$\theta(x,t) = \sqrt{\frac{2}{\pi}} \int_0^t dt' \int_0^{\infty} X_s(\xi,t') e^{-\kappa\xi^2(t-t')} \sin(\xi x) d\xi$$

where $X_s(\xi,t)$ is the Fourier sine transform of the function $\chi(x,t)$.

2. The function $u(\rho,t)$ satisfies the differential equation

$$\frac{\partial u}{\partial t} = \kappa \left(\frac{\partial^2 u}{\partial \rho^2} - \frac{1}{\rho} \frac{\partial u}{\partial \rho} \right) + \chi(\rho,t)$$

for $\rho > 0$, and the initial condition $u(\rho,0) = 0$. Prove that, for $t > 0$,

$$u(\rho,t) = \int_0^t \frac{\exp[-\rho^2/4\kappa(t-t')]}{2\kappa(t-t')} dt' \int_0^{\infty} {}_0Y_0(\eta,t') e^{-\eta^2/4\kappa(t-t')} I_0 \left[\frac{\rho\eta}{2\kappa(t-t')} \right] d\eta$$

3. The function $\theta(\rho,t)$ satisfies the equation of Prob. 2 in the finite cylinder $0 \leq \rho \leq a$. If $\theta(a,t) = 0$ for $t > 0$, and if $\theta(\rho,0) = 0$, show that

$$\theta(\rho,t) = \frac{2}{a^2} \sum_i \frac{J_0(\rho\xi_i)}{[J_1(a\xi_i)]^2} \int_0^t X(\xi_i,t') e^{-\kappa(t-t')\xi_i^2} dt'$$

where the sum is taken over the positive roots of the equation $J_0(a\xi_i) = 0$ and where

$$X(\xi_i,t) = \int_0^a \rho \chi(\rho,t) J_0(\rho\xi_i) d\rho$$

Show that, in particular, if $\chi(\rho,t) = f(t)$, then

$$\theta(\rho,t) = \frac{2}{a} \sum_i \frac{J_0(\rho\xi_i)}{\xi_i J_1(a\xi_i)} \int_0^t f(t') e^{-\kappa(t-t')\xi_i^2} dt'$$

4. The slowing-down density θ of neutrons in the infinite pile $0 \leq x \leq a$, $0 \leq y \leq b$, $-\infty < z < \infty$ satisfies an equation of the type

$$\frac{\partial\theta}{\partial t} = \nabla^2\theta - S(\mathbf{r})U(t)$$

If θ vanishes on the faces of the pile and is initially zero, show that

$$\theta(x, y, t) = \frac{2}{ab} \sqrt{\frac{2}{\pi}} \sum_{n=1}^{\infty} \sum_{m=1}^{\infty} \sin \frac{m\pi x}{a} \sin \frac{m\pi y}{b} \times \int_0^t U(t') dt' \int_{-\infty}^{\infty} e^{-(z^2 - a^2\pi^2/a^2 - b^2\pi^2/b^2)(t-t')} \bar{S}(z, m, n) e^{-i^2 z} dz$$

where

$$\bar{S} = \frac{1}{\sqrt{2\pi}} \int_0^a dx \int_0^b dy \int_{-\infty}^{\infty} S(x, y, z) \sin \left(\frac{m\pi x}{a} \right) \sin \left(\frac{n\pi y}{b} \right) e^{i^2 z} dz$$

Deduce the solution corresponding to a point source $U(t)$ situated at the geometrical center $(\frac{1}{2}a, \frac{1}{2}b, 0)$ of the pile.

MISCELLANEOUS PROBLEMS

- Heat is flowing along a thin straight bar whose cross section has area A and perimeter p . The conductivity of the material of the bar is K , and the rate at which heat is lost by radiation at the point x of the surface is $H(\theta - \theta_0)$ per unit area, where $\theta(x, t)$ is the temperature at a point in the bar and θ_0 is the temperature of its surroundings. If ρ, c are, respectively, the density and specific heat of the material of the bar, show that θ satisfies the equation

$$\frac{\partial \theta}{\partial t} = \kappa \frac{\partial^2 \theta}{\partial x^2} - h(\theta - \theta_0)$$

where $\kappa = K/\rho c, h = Hp/c\rho A$.

Show that the substitution

$$\theta - \theta_0 = \phi e^{-ht}$$

reduces this equation to the one-dimensional diffusion equation.

- Heat is flowing steadily along a thin straight semi-infinite bar one end of which is situated at the origin and maintained at a constant temperature. The bar radiates into a medium at zero temperature. Prove that if temperatures $\theta_1, \theta_2, \theta_3, \dots$ are measured at a series of points on the bar at equal distances apart, then the ratios $(\theta_{r-1} - \theta_{r+1})/\theta_r$ are constant.
- A spherical shell of internal and external radii r_1, r_2 , respectively, has its inner and outer surfaces maintained at constant temperatures θ_1, θ_2 ; the conductivity of the material of the shell is a linear function of the temperature. Show that the heat flowing through the shell in unit time in the steady state is the same as if the conductivity were independent of temperature and had the value appropriate to the temperature $\frac{1}{2}(\theta_1 + \theta_2)$.
- Prove that the diffusion equation

$$\frac{\partial^2 V}{\partial x^2} = \frac{\partial V}{\partial t}$$

possesses solutions of the type

$$V = At^n \cdot {}_1F_1 \left(-n; \frac{1}{2}; -\frac{x^2}{4t} \right)$$

where A and n are constants and ${}_1F_1(x; \beta; z)$ denotes the confluent hypergeometric function of argument z and parameters x and β .

5. Prove that every solution of the one-dimensional diffusion equation defined and continuous in the space-time region $0 < x < l, 0 < t < T$ takes on its least and greatest values on $t = 0$ or on $x = 0, x = l$. Deduce that: (a) the boundary value problem

$$\frac{\partial^2 \theta}{\partial x^2} = \frac{1}{\kappa} \frac{\partial \theta}{\partial t}, \quad \theta(x, 0) = \phi(x), \quad \theta(0, t) = f(t), \quad \theta(l, t) = g(t)$$

has a unique solution in the region $0 < x < l, 0 < t < T$; (b) the solution of the above boundary value problem depends continuously on the functions $\phi(x), f(t), g(t)$.

6. If the concentration c of one component diffusing in a two-phase medium is determined by the equations

$$\frac{\partial c}{\partial t} = D_1 \frac{\partial^2 c}{\partial x^2}, \quad x < 0, \quad \frac{\partial c}{\partial t} = D_2 \frac{\partial^2 c}{\partial x^2}, \quad x > 0$$

the boundary conditions

$$c_1 = kc_2, \quad D_1 \left(\frac{\partial c}{\partial x} \right)_{-0} = D_2 \left(\frac{\partial c}{\partial x} \right)_{+0} \quad \text{at } x = 0$$

and the initial condition

$$c = \begin{cases} c_0 & x < 0 \\ 0 & x > 0 \end{cases}$$

at $t = 0$, show that when $x > 0$,

$$c = c_0 \frac{kD_1^{\frac{1}{2}}}{kD_2^{\frac{1}{2}} + D_1^{\frac{1}{2}}} \left[1 - \operatorname{erf} \left(\frac{x}{2tD_1^{\frac{1}{2}}} \right) \right]$$

and derive the corresponding expression for $x < 0$.

7. Assuming the temperature at a point on the earth's surface (assumed plane) to show a periodic variation from day to day given by

$$\theta = \theta_0 + \theta_1 \cos \omega t$$

investigate the penetration of these temperature variations into the earth's surface, and show that at a depth x the temperature fluctuates between the limits

$$\theta_0 \pm \theta_1 \exp(-x\sqrt{\omega/2\kappa})$$

8. The conducting core of a long cable whose capacity and resistance per unit length are C and R , respectively, is grounded at one end, which may be taken to be infinitely distant. The other end $x = 0$ is raised to a potential V_0 in the interval $0 < t < \tau$ and then lowered again to its initial zero value. If the interval τ is short, prove that the current in the cable is

$$\tau V_0 \sqrt{\frac{C}{R\pi t}} \left(\frac{CRx^2}{4t^2} - \frac{1}{t} \right) e^{-CRx^2/4t}$$

Hence show that the maximum value of the current at a point with co-ordinate x is proportional to x^{-3} .

9. The sphere $r = b$ is maintained at zero temperature, and the sphere $r = a < b$ is heated in such a way that its temperature at time t is $qe^{s^2/4t}$, s and q being constants. The space between the two spheres is filled with a conducting material. Find the temperature at time t at any point between the spheres.

10. Show that the solution of the equation $\frac{\partial^2 \theta}{\partial x^2} = \frac{\partial \theta}{\partial t}$ satisfying the conditions:

- (i) $\theta \rightarrow 0$ as $t \rightarrow \infty$,
 - (ii) $\theta = 0$ when $x = \pm a$ for all values of $t > 0$,
 - (iii) $\theta = x$ when $t = 0$ and $-a < x < a$
- is

$$\theta = \frac{2a}{\pi} \sum_{n=1}^{\infty} \frac{(-1)^{n-1}}{n} \sin\left(\frac{n\pi x}{a}\right) \exp\left(-\frac{n^2 \pi^2 t}{a^2}\right)$$

11. By use of Fourier series, or otherwise, find a solution of the one-dimensional diffusion equation satisfying the following conditions:

- (i) θ is bounded as $t \rightarrow \infty$;
- (ii) $\partial \theta / \partial x = 0$ for all values of t when $x = 0$ and when $x = a$;
- (iii) $\theta = x(a - x)$ when $t = 0$ and $0 < x < a$.

12. Solve $\partial \theta / \partial t = a^2 (\partial^2 \theta / \partial x^2)$ given that:

- (i) θ is finite when $t = -\infty$;
- (ii) $\theta = 0$ when $x = 0$ and $x = \pi$, for all values of t ;
- (iii) $\theta = x$ from $x = 0$ to $x = \pi$ when $t = 0$.

13. A uniform rod of length a whose surface is thermally insulated is initially at temperature $\theta = \theta_0$. At time $t = 0$ one end is suddenly cooled to temperature $\theta = 0$ and subsequently maintained at this temperature. The other end remains thermally insulated: show that the temperature at this end at time t is given by

$$\theta = \frac{4\theta_0}{\pi} \sum_{n=1}^{\infty} \frac{(-1)^n}{2n-1} \exp\left\{-\frac{(2n-1)^2 \kappa \pi^2 t}{4a^2}\right\}$$

where κ is the thermometric conductivity (diffusivity).

14. The boundaries of the rectangle $0 < x < a$, $0 < y < b$ are maintained at zero temperature. If at $t = 0$ the temperature θ has the prescribed value $f(x, y)$, show that for $t > 0$ the temperature at a point within the rectangle is given by

$$\theta(x, y, t) = \frac{4}{ab} \sum_{m=1}^{\infty} \sum_{n=1}^{\infty} F(m, n) \exp\left[-\kappa t \pi^2 \left(\frac{m^2}{a^2} + \frac{n^2}{b^2}\right)\right] \sin\left(\frac{m\pi x}{a}\right) \sin\left(\frac{n\pi y}{b}\right)$$

where
$$F(m, n) = \int_0^a \int_0^b f(x, y) \sin\left(\frac{m\pi x}{a}\right) \sin\left(\frac{n\pi y}{b}\right) dx dy$$

15. The faces of the solid parallelepiped $0 < x < a$, $0 < y < b$, $0 < z < c$ are kept at zero temperature. If, initially, the temperature of the solid is given by $\theta(x, y, z, 0) = f(x, y, z)$, show that at time $t > 0$

$$\theta(x, y, z, t) = \frac{8}{abc} \sum_{m=1}^{\infty} \sum_{n=1}^{\infty} \sum_{q=1}^{\infty} F(m, n, q) e^{-\mu t} \sin\left(\frac{m\pi x}{a}\right) \sin\left(\frac{n\pi y}{b}\right) \sin\left(\frac{q\pi z}{c}\right)$$

where

$$F(m, n, q) = \int_0^a \int_0^b \int_0^c f(x, y, z) \sin\left(\frac{m\pi x}{a}\right) \sin\left(\frac{n\pi y}{b}\right) \sin\left(\frac{q\pi z}{c}\right) dx dy dz$$

and
$$\mu^2 = \kappa \pi^2 \left(\frac{m^2}{a^2} + \frac{n^2}{b^2} + \frac{q^2}{c^2}\right)$$

16. If the face $x = a$ is kept at a constant temperature θ_0 , the other faces being maintained at zero temperature, and if the initial temperature is zero, show that the steady-state temperature is

$$\theta = \frac{16\theta_0}{\pi^2} \sum_{r=1}^{\infty} \sum_{s=1}^{\infty} \frac{1}{(2r-1)(2s-1)} \frac{\sinh(rx)}{\sinh(ra)} \sin \frac{(2r-1)\pi y}{b} \sin \frac{(2s-1)\pi z}{c}$$

where

$$r^2 = \pi^2 \left[\frac{(2r-1)^2}{b^2} + \frac{(2s-1)^2}{c^2} \right]$$

17. Show that the solution $\theta(\rho, z, t)$ of the diffusion equation for the semi-infinite cylinder $0 \leq \rho \leq a, z > 0$ which satisfies the boundary conditions

$$\begin{aligned} \theta = 0, \quad z = 0 \quad 0 \leq \rho \leq a, \quad t > 0 \\ \theta = 0, \quad \rho = a \quad z = 0, \quad t > 0 \end{aligned}$$

and the initial condition

$$\theta(\rho, z, 0) = f(z)$$

is

$$\theta = \frac{2e^{-z^2/4\kappa t}}{\sqrt{\pi\kappa t}} \sum_i \frac{J_0(\xi_i) e^{-\kappa t \xi_i^2}}{a \xi_i J_1(\xi_i a)} \int_0^z f(u) \sinh \left(\frac{uz}{2\kappa t} \right) e^{-u^2/4\kappa t} du$$

where the sum is taken over all the positive roots of the equation $J_0(\xi a) = 0$.

18. The outer surfaces $\rho = a, \rho = b$ ($a < b$) of an infinite cylinder are kept at zero temperature, and the initial temperature is $\theta(\rho, 0) = f(\rho)$ ($b \leq \rho \leq a$). Show that at time $t > 0$ the temperature is given by

$$\theta(\rho, t) = 2 \sum_i \frac{J_0^2(\xi_i/b) f(\xi_i) e^{-\kappa t \xi_i^2}}{J_0^2(a \xi_i) - J_0^2(b \xi_i)} [J_0(\rho \xi_i) G_0(a \xi_i) - J_0(a \xi_i) G_0(\rho \xi_i)]$$

where f is defined to be

$$f = \int_a^b \rho f(\rho) [J_0(\rho \xi_i) G_0(a \xi_i) - J_0(a \xi_i) G_0(\rho \xi_i)] d\rho$$

and ξ_1, ξ_2, \dots are the positive roots of the transcendental equation

$$J_0(b \xi_i) G_0(a \xi_i) - J_0(a \xi_i) G_0(b \xi_i) = 0$$

19. Find the solution of

$$\frac{\partial^2 \theta}{\partial x^2} = \frac{\partial \theta}{\partial t}, \quad t > 0, \quad 0 \leq x < \infty$$

for which

$$\begin{aligned} \theta(x, 0) &= e^{-x} \quad x > 0 \\ \theta(0, t) &= 0 \quad t > 0 \end{aligned}$$

(Note that $e^{-x\sqrt{s}}$ is the Laplace transform of

$$\frac{x e^{-x^2/4t}}{2\pi^{1/2} t^{3/2}})$$

20. The space $x > 0$ is filled with homogeneous material of thermometric conductivity κ , the surface boundary $x = 0$ being impervious to heat. The temperature distribution at time $t = 0$ is given by $\theta = \theta_0(1 - e^{-a^2 x^2})$. Find the temperature distribution at time t .

21. If $\theta(x, t)$ is the solution of the one-dimensional diffusion equation for the semi-infinite solid $x \geq 0$ which satisfies the conditions $\theta(0, t) = \theta_0 \cos \lambda t$, $\theta(x, 0) = 0$, show that

$$\theta = \theta_0 e^{-\lambda x} \cos (nt - \lambda x) - \frac{a}{\pi} \int_0^x e^{-u^2} \sin \left(\sqrt{\frac{u}{\kappa}} x \right) \frac{u \, du}{u^2 - n^2}$$

where $\lambda = \sqrt{n^2/2\kappa}$.

22. The function $\theta(x, t)$ satisfies the one-dimensional diffusion equation and is such that $\theta(x, 0) = \theta_0$, a constant, and

$$\left(\frac{\partial \theta}{\partial x} \right)_{x=0} = h\theta(0, t)$$

Prove that

$$\theta = \theta_0 \operatorname{erf} \left(\frac{x}{2\sqrt{\kappa t}} \right) - \frac{\theta_0}{\sqrt{\kappa \pi t}} \int_0^x e^{-h u^2 - (x-u)^2/4\kappa t} \, du$$

23. Show by means of the Laplace transform $\theta(x, t)$ that the solution of the one-dimensional diffusion in the region $0 \leq x \leq a$ satisfying the conditions

$$\theta(0, t) = f(t), \quad \theta(a, t) = 0, \quad \theta(x, 0) = 0$$

is given by the formula

$$\theta(x, t) = \frac{2\kappa\pi}{a^2} \sum_{n=1}^{\infty} n \sin \frac{n\pi x}{a} \int_0^t f(\tau) e^{-n^2\pi^2\kappa(t-\tau)} \, d\tau$$

24. The boundaries $x = 0, y = 0$ of the semi-infinite strip $0 \leq y \leq b, x > 0$ are kept at zero temperature while the boundary $y = b$ is kept at temperature θ_0 . If the initial temperature is zero, show that

$$\begin{aligned} \theta(x, y, t) &= \frac{2\theta_0}{\pi} \sum_{n=1}^{\infty} \frac{(-1)^{n+1}}{n} \sin \left(\frac{n\pi y}{b} \right) + \frac{2\theta_0}{\pi} \sum_{n=1}^{\infty} e^{-n\pi x/b} \frac{(-1)^n}{n} \sin \left(\frac{n\pi y}{b} \right) \\ &- \frac{4\theta_0}{b^2} \sum_{n=1}^{\infty} n (-1)^n \sin \frac{n\pi y}{b} \int_0^x \frac{e^{-\kappa(\xi^2 + n^2\pi^2/b^2)} \sin(\xi x) \, d\xi}{\xi(\xi^2 + n^2\pi^2/b^2)} \end{aligned}$$

25. Show that the solution $\theta(r, t)$ of the boundary value problem

$$\frac{\partial^2 \theta}{\partial r^2} - \frac{2}{r} \frac{\partial \theta}{\partial r} - \frac{1}{\kappa} \frac{\partial \theta}{\partial t} = 0 \quad 0 \leq r \leq a, t > 0$$

$$\theta(r, 0) = \theta_0 = \text{const.} \quad 0 \leq r < a$$

$$\frac{\partial \theta}{\partial r} + h\theta = 0 \quad \text{when } r = a, t > 0$$

may be expressed in the form

$$\theta(r, t) = \frac{2a^2\theta_0 h}{r} \sum_{n=1}^{\infty} (-1)^{n-1} \frac{[\xi_n^2 + (ah - 1)^2]^{1/2} \sin(r\xi_n/a)}{\xi_n^2 + ah(ah - 1)\xi_n} e^{-\kappa\xi_n^2 t/a^2}$$

where the sum is taken over the positive roots $\xi_1, \xi_2, \dots, \xi_n, \dots$ of the equation

$$\xi + (ah - 1) \tan \xi = 0$$

26. The distribution of temperature in an infinite solid is governed by the equation

$$\frac{\partial \theta}{\partial t} = \kappa \nabla^2 \theta + \psi(t) \theta - \phi(\mathbf{r}, t)$$

Transforming the equation (cf. Prob. 3 of Sec. 1) and making use of the theory of Fourier transforms, show that if initially $\theta = \theta_0(\mathbf{r})$, then at time $t > 0$

$$\begin{aligned} \theta(\mathbf{r}, t) = & (4\pi\kappa t)^{-3/2} \exp \left[\int_0^t \psi(t') dt' \right] \int \theta_0(\mathbf{r}') \exp \left(-\frac{|\mathbf{r} - \mathbf{r}'|^2}{4\kappa t} \right) d\mathbf{r}' \\ & + (4\pi\kappa t)^{-3/2} \exp \left[\int_0^t \psi(t') dt' \right] \int_0^t \frac{\exp \left[-\int_0^{t'} \psi(t'') dt'' \right]}{(t - t')^{3/2}} dt' \\ & \quad \times \int \exp \left[-\frac{|\mathbf{r} - \mathbf{r}'|^2}{4\kappa(t - t')} \right] \phi(\mathbf{r}', t') d\mathbf{r}' \end{aligned}$$

27. A point source of heat of strength Q is moving with velocity $v(t)$ along the line $x = a, z = 0$ in an infinite solid. If initially the temperature of the solid is zero, show that at time $t > 0$

$$\theta(\mathbf{r}, t) = \frac{Q}{8\rho c(\pi\kappa)^{3/2}} \int_0^t \frac{e^{-R^2/4\kappa(t-t')}}{(t-t')^{3/2}} dt'$$

with $R^2 = (x - a)^2 + [y - tv(t')]^2 + z^2$.

If the point source moves in the same way in the interior of the semi-infinite solid $x > 0$ whose boundary is kept at zero temperature, show that

$$\theta(\mathbf{r}, t) = \frac{Q}{8\rho c(\pi\kappa)^{3/2}} \int_0^t [1 - e^{-ax'\kappa(t-t')}] \frac{e^{-R^2/4\kappa(t-t')}}{(t-t')^{3/2}} dt'$$

APPENDIX

SYSTEMS OF SURFACES

In Chap. 2 we made use of some of the properties of systems of surfaces. The object of this appendix is to provide a brief outline of such systems for the benefit of readers unacquainted with them. For a fuller account the reader is referred to R. J. T. Bell, "An Elementary Treatise on Coordinate Geometry of Three Dimensions," 2d ed. (Macmillan, London, 1931), pp. 307-325.

1. One-parameter Systems

If the function $f(x, y, z, a)$ is a single-valued function possessing continuous partial derivatives of the first order with respect to each of its variables in a certain domain, then in xyz space the equation

$$f(x, y, z, a) = 0 \quad (1)$$

represents a one-parameter system of surfaces.

We now fix attention on the member of this system which is given by a prescribed value of a and on the member corresponding to the slightly different value $a + \delta a$, which will have equation

$$f(x, y, z, a + \delta a) = 0 \quad (2)$$

These two surfaces will intersect in a curve whose equations are (1) and (2), and it is easily seen that the curve may also be considered to be the intersection of the surface with equation (1) with the surface whose equation is

$$\frac{1}{\delta a} \{f(x, y, z, a + \delta a) - f(x, y, z, a)\} = 0 \quad (3)$$

As the parameter difference δa tends to zero, we see that this curve of intersection tends to a limiting position given by the equations

$$f(x, y, z, a) = 0, \quad \frac{\partial}{\partial a} f(x, y, z, a) = 0 \quad (4)$$

This limiting curve is called the *characteristic curve* of the system on the surface (1) or, more loosely, the characteristic curve of (1). Geometrically it is the curve on the surface (1) approached by the intersection curve of (1) and (2) as $\delta a \rightarrow 0$.

As the parameter a varies, the characteristic curve (4) will trace out a surface whose equation

$$g(x, y, z) = 0 \quad (5)$$

is obtained by eliminating a between the equations (4). This surface is called the *envelope* of the one-parameter system (1).

For example, the equation

$$x^2 + y^2 + (z - a)^2 = 1$$

is the equation of the family of spheres of unit radius with centers on the z axis. Putting $f = x^2 + y^2 + (z - a)^2 - 1$, we see that $f_z = z - a$, so that the characteristic curve to the surface a is the circle

$$z = a, \quad x^2 + y^2 = (z - a)^2 - 1$$

and it follows immediately that the envelope of this family is the cylinder

$$x^2 + y^2 = 1$$

(cf. Fig. 48). In this particular case it is obvious that the envelope touches each member of the family along the appropriate characteristic curve. We shall now prove that this is true in general.

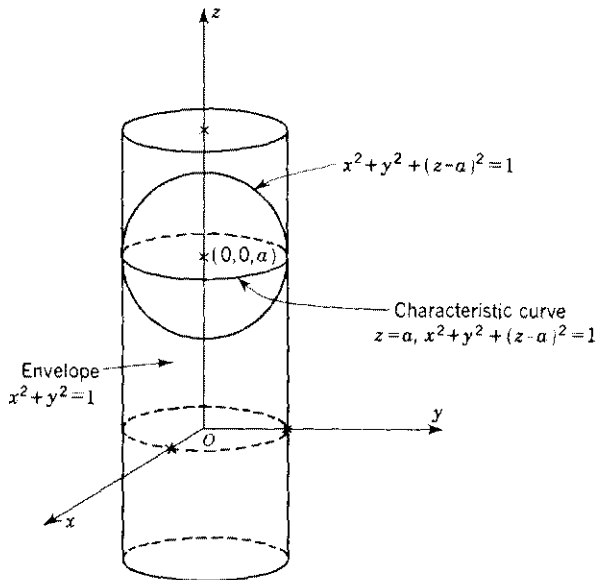

Figure 48

Theorem 1. *Apart from singular points, the envelope touches each member of the one-parameter system of surfaces along the characteristic curve of the system on that member.*

To prove this theorem consider the one-parameter system (1). Since it is a one-parameter system it follows that through any point P of the envelope there is one member of (1) whose characteristic curve passes through $P(x, y, z)$. The direction cosines of the normal to this surface are proportional to (f_x, f_y, f_z) . Now we may consider the envelope to be the surface

$$f(x, y, z, a(x, y, z)) = 0 \quad (6)$$

where $a(x, y, z)$ is determined from the equation

$$\frac{\partial f}{\partial a} = 0 \quad (7)$$

Now the direction cosines of the normal to the surface (6) are proportional to

$$\left(\frac{\partial f}{\partial x} + \frac{\partial f}{\partial a} \frac{\partial a}{\partial x}, \frac{\partial f}{\partial y} + \frac{\partial f}{\partial a} \frac{\partial a}{\partial y}, \frac{\partial f}{\partial z} + \frac{\partial f}{\partial a} \frac{\partial a}{\partial z} \right)$$

an en. on account of (7), reduce to (f_x, f_y, f_z) . Hence the tangent planes to the surface and the envelope coincide.

We have proved that along the appropriate characteristic curve the surface a and the envelope have the same values of (x, y, z, p, q) . In Sec. 8 of Chap. 2 we saw that these numbers specify the *characteristic strip* of the surface a . We may therefore think of the characteristic strip as being the set of small elements of tangent planes which the surface and the envelope have in common along the characteristic curve.

The argument given above breaks down at singular points, i.e., at points at which $f_x = f_y = f_z = 0$, but it is not difficult to show that such points lie on the locus (4). As a consequence singular loci appear in the result.

2. Two-parameter Systems

In a similar way we may discuss the two-parameter system of surfaces defined by the equation

$$f(x, y, z, a, b) = 0 \quad (1)$$

in which a and b are parameters. We consider first the one-parameter subsystem

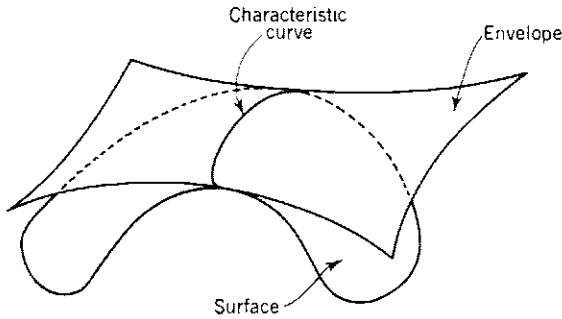

Figure 49

obtained by taking b to be a prescribed function of a ; e.g.,

$$b = \phi(a) \quad (2)$$

This in turn gives rise to an envelope obtained by eliminating a, b from equations (1) and (2) and the relation

$$\frac{\partial f}{\partial a} + \frac{\partial f}{\partial b} \frac{db}{da} = 0 \quad (3)$$

The characteristic curve of the subsystem on the surface (1) is given by equations (1) and (3), in which b has been substituted from (2).

It should be observed that for every form of function $\phi(a)$ the characteristic curve of the subsystem on (1) passes through the point defined by the equations

$$f = 0, \quad f_a = 0, \quad f_b = 0 \quad (4)$$

This point is called the *characteristic point* of the two-parameter system (1) on the particular surface (1). As the parameters a and b vary, this point generates a surface which is called the *envelope* of the surfaces (1). Its equation is obtained by eliminating a and b from the three equations comprising the set (4).

As an example consider the equation

$$(x - a)^2 + (y - b)^2 + z^2 = 1 \quad (5)$$

where a and b are parameters. The two-parameter family corresponding to this equation is made up of all spheres of unit radius whose centers lie on the xy plane. In this instance the equations (4) assume the forms

$$(x - a)^2 + (y - b)^2 + z^2 = 1, \quad x - a = 0, \quad y - b = 0$$

so that the characteristic points of the two-parameter system on the surface (1) are $(a, b, \pm 1)$. In other words, each sphere has two characteristic points. The envelope is readily seen to be the pair of parallel planes $z = \pm 1$.

A subsystem of the two-parameter system (5) is obtained by taking $b = 2a$; the equation of this subsystem is

$$(x - a)^2 + (y - 2a)^2 + z^2 = 1 \quad (6)$$

The characteristic curve of this subsystem is the intersection of the sphere (6) with the plane

$$x + 2y = 5a \quad (7)$$

It is therefore a great circle through the center $C(a, 2a, 0)$ of the sphere normal to the line OC . Its center lies on the line

$$\frac{x}{1} = \frac{y}{2} = \frac{z}{0} \quad (8)$$

The equation of the envelope of this subsystem is obtained by eliminating a from equations (6) and (7). We find that the envelope is a right circular cylinder with axis (8) and unit radius.

Corresponding to Theorem 1 for one-parameter families of surfaces we have:

Theorem 2. *The envelope of a two-parameter system is touched at each of its points P by the surface of which P is the characteristic point.*

The proof is a simple extension of that for Theorem 1. We may consider the envelope to be the surface

$$f\{x, y, z, a(x, y, z), b(x, y, z)\} = 0 \quad (9)$$

where the functions $a(x, y, z)$ and $b(x, y, z)$ are defined by the relations

$$f_a = 0, \quad f_b = 0 \quad (10)$$

The direction cosines of the tangent plane to the envelope at the point $P(x, y, z)$ are therefore proportional to

$$\left(\frac{\partial f}{\partial x} + \frac{\partial f}{\partial a} \frac{\partial a}{\partial x} + \frac{\partial f}{\partial b} \frac{\partial b}{\partial x}, \quad \frac{\partial f}{\partial y} + \frac{\partial f}{\partial a} \frac{\partial a}{\partial y} + \frac{\partial f}{\partial b} \frac{\partial b}{\partial y}, \quad \frac{\partial f}{\partial z} + \frac{\partial f}{\partial a} \frac{\partial a}{\partial z} + \frac{\partial f}{\partial b} \frac{\partial b}{\partial z} \right)$$

and, as a result of equations (10), these reduce to (f_x, f_y, f_z) , showing that the tangent plane to the envelope coincides with the tangent plane to the surface (1) at P , as we had to prove.

3. The Edge of Regression

We shall return now to a consideration of the one-parameter system of surfaces with equation

$$f(x, y, z, a) = 0 \quad (1)$$

Then, as we showed in Sec. 1, the characteristic curve on (1) has equations

$$f(x, y, z, a) = 0, \quad \phi(x, y, z, a) = 0 \quad (2)$$

where $\phi(x, y, z, a) = \frac{\partial}{\partial a} f(x, y, z, a)$. The characteristic curve on a neighboring surface has equations

$$f(x, y, z, a + \delta a) = 0, \quad \phi(x, y, z, a + \delta a) = 0 \quad (3)$$

These two characteristic curves will intersect if the four equations (2) and (3) are consistent or if the equations (2) and

$$\frac{1}{\delta a} \{f(x, y, z, a - \delta a) - f(x, y, z, a)\} = 0 \quad (4)$$

$$\frac{1}{\delta a} \{\phi(x, y, z, a - \delta a) - \phi(x, y, z, a)\} = 0 \quad (5)$$

are consistent.

Both characteristic curves lie on the envelope of the system (1). If they intersect, the locus of their limiting point of intersection as $\delta a \rightarrow 0$ is called the *edge of regression of the envelope of (1)*. It should be noted that this locus is a curve on the envelope.

Letting $\delta a \rightarrow 0$ in equations (4) and (5), we see that the characteristic curves will possess a limiting point of intersection if the equations

$$f = 0, \quad \phi = 0, \quad f_a = 0, \quad \phi_a = 0$$

are consistent; i.e., if

$$f = 0, \quad f_a = 0, \quad f_{aa} = 0 \quad (6)$$

are consistent.

Since there are only three equations to be satisfied, it follows that in general there is always a solution. For this reason we say that "consecutive characteristic curves intersect" at a point given the equations (6). As the parameter a varies, this point generates the edge of regression; its equations are obtained by eliminating the parameter a in two different ways from the equations (6). The edge of regression has the property that it touches each of the characteristic curves of the system.

To illustrate these remarks we consider the one-parameter system of planes whose equation is

$$3a^2x - 3ay + z = a^3 \quad (7)$$

in which a is a parameter. The characteristic curve of the system on the surface (7) has for its equations the equation (7) and

$$a^2 - 2ax + y = 0 \quad (8)$$

The envelope is found by eliminating a between equations (7) and (8). If we multiply equation (8) by a and subtract it from equation (7), we find that

$$a^2x = 2ay - z \quad (9)$$

and eliminating a from equations (8) and (9), we obtain the equation

$$a = \frac{xy - z}{2(x^2 - y)}$$

Substituting this value for a in equation (7), we see that the envelope has equation

$$(xy - z)^2 = 4(x^2 - y)(y^2 - xz)$$

For the edge of regression we have, in addition to equations (7) and (8), the equation $a - x = 0$, so that the edge of regression has freedom equations

$$x = a, \quad y = a^2, \quad z = a^3$$

Alternatively it can be thought of as the intersection of the surfaces

$$y^2 = xz, \quad xy = z$$

4. Ruled Surfaces

We shall now consider briefly some of the properties of a ruled surface. A *ruled surface* is one which is generated by straight lines, which are themselves called *generators*. Typical examples are cones, cylinders, the hyperboloid of one sheet, the hyperbolic paraboloid. We distinguish between two kinds of ruled surface. A *developable* surface is a ruled surface of which "consecutive generators intersect;" a ruled surface which is not developable is called a *skew* surface. Cones are developable, though they are not typical examples, since any two generators intersect, not merely two consecutive generators. Hyperboloids of one sheet and hyperbolic paraboloids are skew surfaces.

A developable surface is so called because it can be "developed" into a plane in the sense that it can be deformed into a part of a plane without stretching or tearing. To see this we consider a set of "consecutive generators" $\lambda_1, \lambda_2, \lambda_3, \dots$ on a developable surface. They intersect as shown in Fig. 50, and the surface consists of small plane elements $\pi_1, \pi_2, \pi_3, \dots$. The element π_1 can be rotated about the line λ_2 until it is coplanar with π_2 . The area $\pi_1 - \pi_2$ can now be rotated about λ_3 until it is brought into the plane π_3 . We can proceed thus until the whole surface is developed into part of a plane.

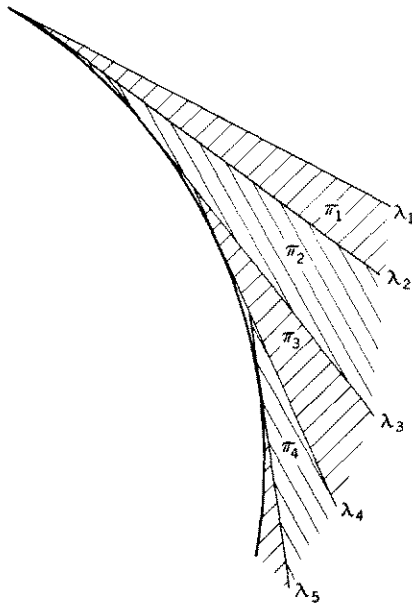

Figure 50

There are two results about developable surfaces which are of value in the theory of partial differential equations:

Theorem 3. *The envelope of a one-parameter family of planes is a developable surface.*

To prove this theorem we note that the equation of a one-parameter family of planes may be written in the form

$$x + ay + f(a)z + g(a) = 0 \quad (1)$$

The characteristic curve is determined by

$$y + f'(a)z + g'(a) = 0 \quad (2)$$

together with equation (1). Since the characteristic curve is the intersection of the planes (1) and (2), it is a straight line. The envelope which is generated by it is therefore a ruled surface. This straight line intersects its consecutive in a point given by the equations (1), (2), and

$$f''(a)z + g''(a) = 0 \quad (3)$$

Since "consecutive generators intersect" at this point, the envelope is a developable surface.

Theorem 4. *The edge of regression of a developable surface touches the generators.*

This theorem follows from the fact that a developable surface consists of two sheets which meet one another at a cuspidal edge, one sheet being generated by the forward tangents to the edge of regression, the other sheet by backward tangents.

SOLUTIONS TO THE ODD-NUMBERED PROBLEMS

Chapter 1

Section 1

$$1. p^2 = \frac{l^2}{a} + \frac{m^2}{b} + \frac{n^2}{c}$$

Section 3

$$1. x + y + z = c_1, \quad xyz = c_2$$

$$3. (x + y)(z + 1) = c_1, \quad (x - y)(z - 1) = c_2$$

2. $a x^2 + b y^2 + c z^2 = c_1, \quad x^2 + y^2 + z^2 = c_2$
 4. $x^2 + y^2 + z^2 = c_1, \quad \frac{1}{x} + \frac{1}{y} + \frac{1}{z} = c_2$

Section 4

1. The orthogonal trajectories are the intersections of the system $xyz + d = kx$ (k a parameter) with the surface $x^2 + y^2 - 2fyz + d = 0$.

3. The orthogonal trajectories are the curves

$$3z - 2 \left(x - \frac{1}{x} \right) = c_1, \quad 2y = x^2$$

5. The orthogonal trajectories are the curves

$$x + c_1 = z + \frac{1}{2z} - \frac{1}{6z^3}, \quad (x - y)z = 1$$

Section 5

1. Integrable; $xy + z^2 = c$.

3. Integrable; $x_1^2 - cz^3$.

5. The equation is not integrable.

Section 6

$$1. (a - x)^2 + z = y(c - y)$$

$$3. yz = zx + xy = c(x + y + z)$$

$$5. yz + 1 = (xy + 1)(cy + 1)$$

$$7. y^2 - z^2 = \frac{2yz}{x} = C$$

Miscellaneous Problems

$$1. (a) x^2 y^2 z^3 = c_1, \quad (x^3 + y^3)z^3 = c_2$$

$$(b) y = c_1 x, \quad x^2 + y^2 + z^2 = c_2 x$$

$$(c) x - y = c_1, \quad xy + yz + zx = c_2$$

3. The integral curves are given by the equations

$$xz + ay = c_1(az - xy), \quad (xz + ay)y = (c_2 - z)(az - xy)$$

from which it follows that they are the intersections of the quadrics $xz + ay - c_1(az - xy)$ by the planes $c_1 y + z = c_2$ and are therefore conics.

- 5. $y^2 = 2z, \quad y = c_1 e^{x-z}$
- 7. $x^2 - y^2 = 2az, \quad (x - y)^2 + 2z^2 = c_1$
- 13. $x(\frac{1}{3}x^2 - y^2) = c_1, \quad xy = z$

Chapter 2

Section 2

- 1. (a) $pq = z$
- (b) $px + qy = q^2$
- (c) $z(px - qy) = z^2 - 1$

Section 4

- 1. $x^2 + y^2 + z^2 = f(xy)$
- 2. $x^2 + z - y^2 = x f(\frac{z}{y})$
- 3. $(x + y)(x + y + z) = f(xy)$
- 4. $y z - y^2 = f(x^2 + y^2)$
- 5. $F(x^2 + y^2 - z^2, xy + z) = 0$
- 6. $z = xy f(x^2 + y^2)$

Section 5

- 1. $x^2 + y^2 - 2x = z^2 - 4z$
- 2. $x^2 - 2xy + z - x^2 z^2 + z = f(y + xz) + x^2 y^2 + z - xz - y - 1$
- 3. $z^3(x^3 + y^3)^2 = a^9(x - y)^3$
- 4. $z^{\frac{1}{2} - 2z} = f(\frac{x}{yz}), \quad f(\frac{x}{yz}) = \frac{x}{yz^2} - 1$
- 5. $(x - y + z)^2 + z^4(x + y + z)^2 - 2z^2(x - y + z) - 2z^4(x + y + z) = 0$

Section 6

- 1. $(x^2 + y^2 + 4z^2)(x^2 - y^2)^2 = a^4(x^2 + y^2)$
- 3. The general equation is

$$x^2 + y^2 + z^2 = z f\left(\frac{2x^2 + y^2}{z^2}\right)$$

The case quoted is obtained by taking $f(\xi)$ to be constant.

$$(x^2 + y^2 + z^2)^2 = c_1(2x^2 + y^2)$$

Section 7

- 1. $(x + y - z)^2 = 4xy$

Section 8

- 1. Characteristics:
 - $x = 2v(e^t - 1), \quad y = \frac{1}{2}v(e^t + 1), \quad z = v^2 e^{2t};$
 - $16z = (4y + x)^2$
- 3. Characteristics:
 - $x = 2v(2 - e^{-t}), \quad y = 2\sqrt{2}v(e^{-t} - 1), \quad z = -v^2 e^{-2t};$
 - $4z + (x + \sqrt{2}y)^2 = 0$

Section 9

- 1. $z = x + c_1(1 + xy)$

Section 10

- 1. $(x + b)^2 + y^2 = az^2$
- 3. $z = bx^a y^{1/a}$
- 5. $z = \frac{2}{3}(y + a)^{\frac{3}{2}} + \frac{1}{9} + \frac{1}{3x^2} + be^{3/x^2}$
- 7. $z = \frac{ax}{y^2} + \frac{b}{y} - \frac{a^2}{4y^3}$

Section 11

1. $z = -ax - \frac{ay}{a-1} - b$

2. $4(x^2-1)z = -(ax+y+z)^2$

3. $z^2 = 2(a+1)\left(x - \frac{y}{a}\right) - b$

4. $z = \ln|x + \sqrt{x^2 - a^2}| + \frac{1}{a} \tan^{-1}\left(\frac{z}{a}\right) + b$

5. $z = \frac{1}{3}(x^2 + a^2)^{\frac{3}{2}} + (y^2 - a^2)^{\frac{3}{2}} + b$

6. $z = ax + yz + \frac{1+y^2}{xz}$

Section 12

1. $(x + ay - z - b)^2 - 4bx, \quad xy = z(y - 2)$

5. $(x - a)^2 + y^2 + z^2 - 2by = 0, \quad (y^2 + 4y + 2z^2)^2 = 8x^2y^2$

Section 13

3. $u = (ax^2 - b)^{\frac{1}{3}} + ay^{\frac{1}{3}} + \frac{z}{b} + c$

Section 14

1. $\eta = \eta_0 \cos \frac{2\pi}{\lambda} \left\{ x - \frac{mt}{(h - \eta)^2} \right\}$

3. $P_n(t) = \frac{(\lambda/\beta)^n}{n!(e^{\lambda/\beta} - 1)}$

Miscellaneous Problems

3. $f(\zeta) = 2\zeta + 1$

2. $x^2 + y^2 + z^2 = a^2 + \frac{1}{2}(4x - y + 3z - 6a)^2$

5. $p^2 + q^2 = \tan^2 \gamma$

7. $(x^2 + y)(xz - y) = zy$

9. The integral surfaces are generated by the curves

$$x^2 + y^2 - a^2 = c_1 z^2, \quad y = c_2 z$$

which are obviously conics;

$$3z^2(x^2 + y^2) = x^2(x^2 + y^2 - a^2)$$

11. $f[(x + y)z, lx^2 + my^2 + nz^2] = 0$

$$lx^2 + my^2 + nz^2 = (x + y)z \left[\frac{1}{4}l + \frac{1}{4}m + n \right] + \frac{1}{2}(l - m)(x + y)z$$

12. $x + yz = x - y$

$$+ \frac{1}{4}(l + m)(x + y)^2 z^2$$

13. $z - ax + ay = b[(x + y)^2 - 8a]$

15. $2z \sqrt{x^2 - a + b} = x^2 + 2y^2 + z^2$

17. $xz = ay + b(1 - ax)$

19. $z^2 = x^2(2y^2 - 1)$

10. $u = 2\sqrt{\frac{x^2 - y^2}{3}} + \frac{1}{2} \ln \frac{1}{3} \frac{x+y}{x-y}$

21. $4x^2 z^2 = (x^3 + 2y)^2$

Chapter 3

Section 3

5. $\sigma_x = c + \frac{kx}{a} \pm 2k \left(1 - \frac{y^2}{a^2} \right)^{\frac{1}{2}}, \quad \sigma_y = c + \frac{kx}{a}$

Section 4

3. $z = f_1(x + y) + f_2(x - y) + f_3(2x + y) - \frac{1}{2}xe^{x+y}$

5. $z = \frac{1}{6}(\log x)^3 + f_1\left(\frac{x}{y}\right) + f_2(xy)$

Section 5

$$1. z = \int_0^x d\xi \int_0^y f(\xi, \eta) d\eta + f_1(x) + f_2(y)$$

$$z = xy(xy + 1) + f_1(x) + f_2(y)$$

3. If the equation

$$R(c) \frac{d^2z}{dx^2} - P(c) \frac{dz}{dx} + Z(c)z = W(x, c)$$

has solution $z = c_1 f(x, c) + c_2 g(x, c)$, then the given equation has solution

$$z = f_1(y) f(x, y) + f_2(y) g(x, y);$$

$$z = \frac{e^x}{(1+y)^2} + f_1(y)e^{-xy} + f_2(y)e^{-x/y}$$

$$5. z = (x^2 - y^2)f_1(x^2 + y^2) + f_2(x^2 + y^2)$$

Section 6

$$3. (x - 3\mu t)^3 = Ct, \text{ where } C \text{ is a constant.}$$

Section 7

1. (a) Parabolic; (b) hyperbolic; (c) elliptic; (d) elliptic; (e) parabolic.

Section 8

$$3. z = x \log \frac{x(x+y)}{x^2+1} + y \log \frac{y(x+y)}{y^2+1}$$

$$5. z = 2x^3 - 3x^2y + 3xy^2 - 2y^3$$

Section 9

$$3. V = \sum_n c_n \left(\frac{r}{a}\right)^n \cos(n\theta)$$

Section 10

$$3. z(x, y) = k \left[1 - \operatorname{erf} \frac{y}{2\sqrt{x}} \right]$$

$$\text{where } \operatorname{erf}(\xi) = \frac{2}{\sqrt{\pi}} \int_0^\xi e^{-u^2} du.$$

Section 11

$$3. y = \phi(z) + z\psi(x)$$

$$5. y = f(x+z) + g(z)$$

Miscellaneous Problems

$$3. \sigma_r = \frac{2}{r^2}(Bx - Ay), \quad \tau_{r\theta} = \sigma_\theta = 0$$

$$5. z = xf_1(y) + yf_2(x)$$

$$z = \frac{(n-1)xy^{n-1} - x^{n-1}y}{n-2}$$

$$7. z = \frac{1}{3}xy^3 + f(y+2ix) + g(y-2ix)$$

$$z = y^2 - 4x^2 + \frac{4}{3}x^3y$$

$$z = (x+y)f_1(xy) + f_2(xy)$$

Chapter 4

Section 2

3. The potential is due to: (a) a uniform density $\rho = 3/(2\pi)$ of matter within the sphere $r = a$; (b) a surface density $\sigma = -3(4x^2 - y^2 - z^2)/(4\pi a)$ on the sphere $r = a$.
5. $\frac{1}{2}(k - 1)$

Section 3

1. $A \log \{(x^2 + y^2)^2 - 2a^2(x^2 - y^2) + a^4\} + B$

Section 6

1. If $0 \leq \theta \leq \frac{1}{2}\pi$, $r < a$,

$$\psi = 2\pi\sigma a \sum_{n=0}^{\infty} \frac{(-1)^n \left(-\frac{1}{2}\right)_n}{n!} \left(\frac{r}{a}\right)^{2n} P_{2n}(\cos \theta) - 2\pi\sigma z$$

but if $r > a$,

$$\psi = 2\pi\sigma a \sum_{n=0}^{\infty} \frac{(-1)^{n+1} \left(-\frac{1}{2}\right)_{n-1}}{(n-1)!} \left(\frac{a}{r}\right)^{2n+1} P_{2n}(\cos \theta)$$

where $(a)_n = a(a+1) \cdots (a+n-1)$.

Section 7

1. If the polar axis is taken along the direction of the field,

$$\psi = -E \left(1 - \frac{a^3}{r^3}\right) r \cos \theta$$

3. If the polar axis is taken along the direction of the uniform stream,

$$\psi = -U \left(1 + \frac{a^3}{2r^3}\right) r \cos \theta$$

Section 12

1. $\phi + i\psi = (1 - 2i)(\sin z + z^2)$, $z = x + iy$

Miscellaneous Problems

23. $\frac{6\pi\sigma\omega(a_2 - a_1)}{c(\mu + 2)}$

27. The potential at a point distant r ($< a$) from the center is

$$2\pi\gamma\sigma \sum_{n=0}^{\infty} (-1)^n \frac{\left(-\frac{1}{2}\right)_n}{n!} \left(\frac{1}{b^{2n+1}} - \frac{1}{a^{2n+1}}\right) r^{2n} P_{2n}(\cos \theta)$$

$0 < r < a < b$. The magnitude of the attraction at a point in the plane of the disk distant r ($< a$) from the center is

$$4\pi\gamma\sigma \sum_{n=0}^{\infty} \frac{\left(-\frac{1}{2}\right)_{n+1} \left(-\frac{1}{2}\right)_{n+1}}{n!(n+1)!} \left(\frac{1}{a^{2n+3}} - \frac{1}{b^{2n+3}}\right) r^{2n}$$

33. The potential at an external point is

$$\frac{\mathbf{m} \cdot (\mathbf{r} - \mathbf{f})}{|\mathbf{r} - \mathbf{f}|^3} - \frac{(\mu - 1)a}{(\mu + 1)r} \frac{\mathbf{m} \cdot (\boldsymbol{\rho} - \mathbf{f})}{|\boldsymbol{\rho} - \mathbf{f}|} + \frac{(\mu - 1)a}{(\mu + 1)^2 r} \int_0^1 \frac{\mathbf{m} \cdot (\lambda \boldsymbol{\rho} - \mathbf{f})}{|\lambda \boldsymbol{\rho} - \mathbf{f}|} \lambda^{-\mu/(\mu+1)} d\lambda$$

where $\boldsymbol{\rho} = a^2 \mathbf{r}/r^2$.

39. The complex potential is

$$w = -m \log(z^2 - c^2) - m \log\left(z^2 - \frac{a^4}{c^2}\right) \div 2m \log z$$

41. (a) $\psi = \frac{1}{2}\omega c^2 e^{2(x-\xi)} \cos 2\eta$, where $x = c \cosh \xi \cos \eta$

$$y = c \sinh \xi \sin \eta, \quad a = c \cosh \alpha, \quad b = c \sinh \alpha$$

(b) $\psi = ce^{(x-\xi)}(V \cosh \alpha \cos \eta - U \sinh \alpha \sin \eta)$

(c) $\psi = \frac{1}{4}\omega c^2 e^{2(\alpha-\xi)} \cos 2\eta + c\omega e^{\alpha-\xi}(x_0 \cosh \alpha \cos \eta + y_0 \sinh \alpha \sin \eta)$

45. The complex potential is $w = 2m \log(e^{\pi z/b} - 1)$.

49. $z = \sinh\left(\frac{\pi \zeta}{2\alpha}\right)$

51. $u_r = -\frac{2\gamma}{\pi} \left(\frac{z \cos \theta + a \sin \theta}{rR} \right), \quad u_z = \frac{2\gamma \sin \theta}{\pi R}$

where $R^4 = (r^2 + z^2 - a^2)^2 + 4a^2 r^2, \quad \tan 2\theta = \frac{2ar}{r^2 + z^2 - a^2}$

Chapter 5

Section 4

3. $z = \frac{16va}{\pi^3 c} \sum_{r=0}^{\infty} \sum_{s=0}^{\infty} \frac{(-1)^{r+s}}{(2r+1)(2s+1)\alpha_{rs}} \sin \frac{(2r+1)\pi}{8} \sin \frac{(2s+1)\pi}{8} \sin \frac{(2r+1)\pi x}{a}$
 $\times \sin \frac{(2s+1)\pi y}{a} \sin \left(\frac{\pi \alpha_{rs} ct}{a} \right)$

where $\alpha_{rs}^2 = (2r+1)^2 + (2s+1)^2$

Section 5

3. $\psi = -\frac{aA \sin(kr) \cos(kct)}{kcr \sin(ka)}$

Section 6

3. $\psi = \begin{cases} 0 & r - ct > a \\ \frac{\kappa[a^2 - (r - ct)^2]}{4cr} & -a < r - ct < a \\ 0 & r - ct < -a \end{cases}$

$$\frac{\partial \psi}{\partial t} = \begin{cases} 0 & r - ct > a \\ \frac{\kappa(r - ct)}{2} & -a < r - ct < a \\ 0 & r - ct < -a \end{cases}$$

Miscellaneous problems

1. $\frac{2ac\rho}{[(c\rho + c'\rho')^2 + \sigma^2 m^2]^{\frac{1}{2}}}$

$$7. \quad y = -\frac{4I}{\pi\rho c} \sum_{s=1}^{\infty} \frac{1}{s} \sin\left(\frac{s\pi}{6}\right) \cos\left(\frac{s\pi}{2}\right) \sin\left(\frac{s\pi x}{l}\right) \sin\left(\frac{s\pi ct}{l}\right)$$

$$9. \quad u = \frac{1}{12} x t (x^2 - t^2)$$

$$19. \quad \pi \left(\frac{5T}{\sigma A}\right)^{\frac{1}{2}}$$

$$31. \quad -\frac{1}{2} i \int_{L_1} f(x') H_0^{(2)}(k\rho) dx'$$

35. The amplitude of the reflected wave is

$$\frac{\sin 2\alpha - \sin 2\beta}{\sin 2\alpha + \sin 2\beta}$$

where $\sqrt{\epsilon} \sin \beta = \sin \alpha$.

$$37. \quad f(\xi) = 2C \int_a^{\sqrt{\xi}} v^2 e^{-ikv^2} dv$$

Chapter 6

Section 4

$$1. \quad \theta = \frac{4}{\pi} \sum_{r=1}^{\infty} \frac{(-1)^r}{(2r+1)^2} \sin(2r+1)x \cdot e^{-(2r+1)^2 kt}$$

Section 5

$$1. \quad \theta = \frac{1}{2\pi i} \int_{\gamma-i\infty}^{\gamma+i\infty} \bar{f}(s) \frac{\sinh[\kappa^{-\frac{1}{2}} s^{\frac{1}{2}}(a-x)]}{\sinh(\kappa^{-\frac{1}{2}} s^{\frac{1}{2}} a)} e^{st} ds$$

$$5. \quad (\delta^2 + 4\nu t)^{-\frac{1}{2}} \exp\left(\frac{-z^2}{\delta^2 + 4\nu t}\right)$$

Section 6

1. (a) If $\theta(a,t) = \phi_1(t)$, $\theta(b,t) = \phi_2(t)$, $\theta(x,0) = f(x)$, then

$$\theta(x,t) = \int_a^b G(x,t) f(x) dx + \kappa \int_0^t \left\{ \phi_1(t') \left(\frac{\partial G}{\partial x'}\right)_{x'=a} - \phi_2(t') \left(\frac{\partial G}{\partial x'}\right)_{x'=b} \right\} dt'$$

where the Green's function $G(x,t)$ satisfies

$$G_t = \kappa G_{xx}, \quad G(a,t) = G(b,t) = 0 \quad t > 0$$

$$G(x,0) = 0 \quad a \leq x \leq b$$

$$(b) \quad \theta(x,t) = \frac{1}{2\sqrt{\pi\kappa t}} \int_0^{\infty} f(x') [e^{-(x-x')^2/4\kappa t} - e^{-(x+x')^2/4\kappa t}] dx' \\ + \frac{x}{2\sqrt{\pi\kappa}} \int_0^t \phi(t') \frac{e^{-x^2/4\kappa(t-t')}}{(t-t')^{\frac{3}{2}}} dt'$$

Miscellaneous Problems

3. If $k = k_0 + k_1\theta$, then the flux of heat through the shell is

$$Q = \frac{4\pi(\theta_1 - \theta_2)[k_0 + \frac{1}{2}k_1(\theta_1 + \theta_2)]r_1 r_2}{r_1 - r_2}$$

$$7. \theta = \theta_0 + \theta_1 \exp \left[-\left(\frac{\omega}{2\kappa}\right)^{\frac{1}{2}} x \right] \cos \left[\omega t - \left(\frac{\omega}{2\kappa}\right)^{\frac{1}{2}} x \right]$$

$$9. \theta(r,t) = \frac{qae^{s^2 t} \sinh [s(b-r)\kappa^{-\frac{1}{2}}]}{r \sinh [s(b-a)\kappa^{-\frac{1}{2}}]}$$

$$11. \theta(x,t) = -\frac{a^2}{\pi} \sum_{r=1}^{\infty} \frac{1}{r^2} \cos \left(\frac{2\pi r x}{a} \right) e^{-4\pi^2 r^2 \kappa t / a^2}$$

$$19. \theta(x,t) = e^{t-x} - \frac{x e^t}{2\sqrt{\pi}} \int_0^t e^{-\tau - x^2/4\tau} \tau^{-\frac{3}{2}} d\tau$$

INDEX

- Abel's equation, 178, 180*n.*
Absolute temperature, 41
Absorption of heat, 275
Accessible points, 34
Adiabatic law, 258
Ahlfors, L. V., 185*n.*
d'Alembert's solution, 215, 224
Analytical mechanics, 8
Appel's functions, 137
Arc length, 4
Axially symmetrical potential problems, 161
- Baker, B. B., 241*n.*
Bars, vibrations of, 210, 266
Bartels, R. C. F., 278*n.*
Basset, G., 177
Bell, R. J. T., 118*n.*, 309
Bernoulli's theorem, 187
Bernstein, D., 48*n.*, 119
Bessel functions, 127, 159
 spherical, 234
Bessel's equation, 126, 159
Bicharacteristics, 118
Biharmonic equation, 95
Birth and death processes, 82
Blasius' theorem, 193
Bocher, M., 178*n.*, 180*n.*
Born, M., 37*n.*
Boundary value problems, 151–155,
 175–179, 278–282
Bremmer's relations, 272
Buchdahl, H. A., 35*n.*
Busbridge, I. W., 177*n.*
- Cable, 90, 211, 304
Calculus of variations, 174, 226, 230
Canonical forms, 106
Capacity of condenser, 189
Carathéodory, C., 39*n.*
Carathéodory's axiom, 41
Carathéodory's theorem, 33
Carlsaw, H. S., 275*n.*
Cauchy's method, 61
Cauchy's problem, for first-order
 equations, 47
 for second-order equations, 110
 for wave equation, 221
Cauchy-Riemann equations, 154, 185
Central conicoid, 7
Chadwick, J., 7*n.*
Chain, 93
Chandrasekhar, S., 82*n.*
Characteristic, 111
Characteristic base curve, 111
Characteristic cone, 118
Characteristic curve, 111, 309
 of second-order equations, 110
 in three variables, 115
Characteristic equations, 64
Characteristic point, 311
Characteristic strip, 63, 311
Characteristic surfaces, 117
Charpit's method, 69, 134
Churchill, R. V., 154, 219*n.*, 278*n.*
Churchill problem, 154, 155
Circle theorem, 192
Clairaut equations, 72
Compatible systems, 67
Complementary function, 97
Complete integral, 49, 60
Complex potential, 187
Compressible fluid, 114
Conductance, 91
Conducting media, 277
Conduction of heat, 274
Conduction vector, 143
Conductivity, 274
Confluent hypergeometric function, 303
Conformal transformation, 190
Conoid, 118
Convolution theorem, 302
Copson, E. T., 177, 241*n.*, 254, 258, 261
Copson's method, 179
Copson's theorem, 179
Coulson, C. A., 236*n.*

- Courant, R., 231
 Crack problems, 179
 Curves, 3, 10
 systems of, 15
 Cylindrical waves, 236
- D* function, 254
 Damped oscillations, 266
 Developable surface, 314
 Dielectric constant, 143
 Dielectrics, 143
 Diffraction, 246
 Diffusion of vorticity, 276
 Diffusion coefficient, 276
 Diffusion equation, 91, 139, 275–308
 elementary solution of, 282
 Green's function for, 294–298
 with sources, 299–302
 Dipole, 143
 Dirac delta function, 252
 Direction cosines, 4
 Dirichlet's principle, 175
 Dirichlet's problem, 151, 169, 174
 for circle, 195
 for half plane, 195
 for semi-infinite space, 170
 for sphere, 171
 for two dimensions, 193–196
 Discriminant, 106
 Diverging wave, 235
 Domain, of dependence, 224
 of influence, 224
 Dual integral equations, 179
 Duhamel's theorem, 279
 Dynamical systems, 8
- Earth's temperature, 304
 Edge of regression, 313
 Eigenvalue, 228
 Eigenvalue problems, 231
 Elastic solid, 95, 136, 213
 Electrical double layer, 148
 Electrified disk, 175
 Electrode, 143
 Electromagnetic pulse, 294
 Electromagnetic waves, 212, 234, 236,
 249, 252, 270–273
 Electrostatic energy, 158
 Electrostatic field, 92
 Electrostatic potential, 142
 Electrostatics, 141, 158, 162, 167, 188
- Elementary solutions, of diffusion equation, 282
 of Laplace's equation, 145
 of wave equation, 215
 Elliptic equation, 108, 118
 Ellis, C. D., 7*n*.
 Envelope, 309, 312
 Equations, with constant coefficients,
 96–104
 with variable coefficients, 105–109
 (See also specific equations)
 Equipotential surfaces, 148
 Error function, 284
 Euler-Lagrange equation, 174
 Evans, G. C., 146*n*.
 Exact equation, 19
 Existence of solutions, 9, 48
 Expanding gas cloud, 262
- Feller, W., 82*n*.
 Feshbach, H., 164*n*.
 Finite transforms, 229
 Fink's law, 276
 First law of thermodynamics, 39
 Flexural vibrations, 266
 Flux of heat, 275
 Fokker-Planck equation, 82
 Forsyth, A. R., 134*n*.
 Fourier cosine transform, 128
 Fourier series, 160, 219, 242
 Fourier sine transform, 128
 Fourier transform, 128
 Fourier's solution, 293
 Fourier-Bessel series, 160, 229
 Franklin, P., 120
- Gallop, J., 177
 Gas-thermometer scale, 41
 Gauss' law, 92
 Gauss' theorem, 144
 General integral, 49, 60
 General solution, 49
 Generalized form of Green's theorem,
 122
 Generation of heat, 275
 Generator, 314
 Gillespie, R. P., 181*n*.
 Golomb, M., 9, 15*n*., 126
 Goursat, E., 9*n*.
 Gravitation, 141
 Green, G., 175*n*.
 Green's equivalent layer, 148

- Green's function, 120, 121
 for diffusion equation, 294–298
 for Laplace's equation, 167–174
 for two-dimensional equation,
 193–196
 for wave equation, 222, 244–248
- Green's theorem, 92, 148, 167
 generalized form, 122
- Group velocity, 236
- Hamilton-Jacobi equation, 81
- Hamiltonian function, 8, 81
- Hankel functions, 237
- Hankel transform, 128
- Harmonic equation, 92
 (See also Laplace's equation)
- Harmonic oscillator, 8
- Harnack's theorems, 196, 197
- Heat function, 275
- Heaviside's unit function, 266
- Heavy string, 8
- Helmholtz's equation, 219
- Helmholtz's solution, 239
- Helmholtz's theorems, 240
- Hencky-Mises condition, 95, 136
- Hilbert, D., 111, 231
- Homogeneous equations, 28
- Hydration of cement, 275
- Hyperbolic equation, 108, 118
- Image system, 167
- Incompressible fluid, 187
- Inductance, 91
- Integrable equations, 19, 21
- Integral equations, 178, 183
- Integral strip, 63, 110
- Integral surface, circumscribing given
 surface, 76
 passing through curve, 56, 73
- Integral transforms, 126–131
- Integrating factor, 19, 21
- Internal energy, 40
- Inversion, 152, 164
- Inversion theorem, 127
 Kelvin's, 164
- Irreducible equations, 102
- Irreducible operator, 98
- Irrational motion, 142, 157
- Jacobi's method, 78
- Jäger, J. C., 275*n*.
- Jost, W., 276*n*.
- Joule's law, 39
- Kelvin's inversion theorem, 164
- Kelvin's theorem on harmonic functions,
 197
- King, L. V., 177
- Kirchhoff's solution, 239
- Kirchhoff's theorems, 242
- Kober, H., 192
- Kowalewski, S., 49
- Lagrange's equation, 50
- Lamb, H., 95*n*.
- Lamé's constants, 213
- Landé, A., 39*n*.
- Laplace transform, 128, 290, 297
- Laplace's equation, 92, 109, 141–208
 elementary solution of, 145
 Green's function for, 167–174
- Laplacian operator, 93, 164
- Lass, H., 21*n*., 93*n*., 148*n*.,
- Laurent's series, 162
- Legendre functions, 156
- Legendre polynomials, 156
- Legendre series, 157, 162, 173
- Legendre's associated equation, 156
- Legendre's associated functions, 157
- Legendre's differential equation, 156
- Lienard-Wichert potentials, 253
- Linear equations, 47, 89
 of first order, 49
- Linear hyperbolic equations, 119
- Liouville's theorem, 197
- Lipschitz's condition, 9, 119
- Love, A. E. H., 95*n*.
- Logarithmic potential, 182
- Longitudinal sound waves, 210, 257
- MacDonald, H. M., 177
- Magnetostatics, 143
- Markhoff process, 82
- Maxwell's equations, 93, 212, 252, 270,
 271, 277
- Mean value, 243
- Mechanical work, 39
- Membrane, vibrations of, 139, 211,
 226–232
- Milne-Thompson, L. M., 192*n*.
- Mixed boundary value problems,
 175–179

- Monge's method, 131
 Monochromatic sound waves, 246, 248, 269
 Morse, P. M., 164*n.*
 Muskhelishvili, N. I., 179, 183
- Natani's method, 30, 32
 Nehari, Z., 192
 Neumann's problem, 153
 Neutrons, 276
 Nonhomogeneous wave equation, 249
 Nonlinear equations, of first order, 59
 of second order, 131
 uniform, 132
 Normal to surface, 5
- One variable separable, 28
 Order of equation, 44
 Orthogonal surfaces, 57
 Orthogonal trajectories, 15
- Parabolic equation, 108, 118
 Parametric equations, 2, 37
 Partial differential equation, 44
 Particular integral, 97
 Pfaffian differential equation, 18–33
 Pfaffian differential form, 18
 Phase velocity, 236
 Pile, 302
 Plane element, 62
 Plastic body, 95
 Poincaré, H., 91
 Poincaré's solution, 243
 Poisson's equation, 92, 141, 257
 Poisson's integral, 172, 196, 283
 Poisson's ratio, 95
 Poisson's solution, 239, 243
 Potential of a disk, 139
 Potential equation (*see* Laplace's equation)
 Primitive, 21
 Punching problems, 179
- Quantity of heat, 40
 Quantum electrodynamics, 254
 Quasi-linear equation, 132
- Radiation from surface, 144, 275
 Radioactive decay, 7, 275
 Reciprocal cone, 118*n.*
- Reducible operator, 98
 Reduction to an ordinary equation
 Riemann invariants, 258
 Riemann's method, 119
 Riemann-Green function, 121
 Riemann-Liouville integral, 254
 Riemann-Volterra solution, 221–22
 Retarded potential, 251
 Retarded value, 251
 Riesz, M., 254
 Riesz's integrals, 254–257
 Ruled surface, 314
 Rutherford, E., 7
- Scalar potential, 212, 252
 Second law of thermodynamics,
 Second-order equations in physics,
 Self-adjoint operator, 123, 222
 Separable equations, 72
 Separation of variables, 123, 156, 2
 Shanks, M. E., 9, 15*n.*, 126
 Simple wave, 258
 Simultaneous differential equations
 Singular integral, 60
 Singular integral equations, 179, 18
 Singular points, 310
 Skew surface, 314
 Slow motion of viscous fluid, 95
 Slowing down of neutrons, 276
 Slowing-down density, 276
 Sneddon, I. N., 127*n.*, 156*n.*, 159*n.*,
 229, 234*n.*, 251, 276*n.*, 278*n.*, 2
 Soddy, F., 7
 Solutions, elementary (*See* Elementary solutions)
 existence of, 9, 48
 general, 49
 satisfying given conditions, 73
 (*See also* specific solutions)
 Sound waves, 94, 210, 211, 233,
 236, 246, 257
 longitudinal, 210, 257
 monochromatic, 246, 248, 269
 Source function, 275, 299
 Space form of wave equation, 209
 Spherical Bessel functions, 234
 Steady currents, 143
 Steady flow of heat, 144
 Stieltjes measure, 147
 Stieltjes potentials, 146
 Stochastic processes, 82
 Stratton, J. A., 234
 Stream function, 187