

Second Edition

MCO_{in}Qs

COMPUTER SCIENCE

Timothy J Williams



Contents

<i>Preface to the Second Edition</i>	<i>vii</i>
<i>Preface to the First Edition</i>	<i>viii</i>
<i>Acknowledgements</i>	<i>x</i>
1. Programming with C	1
2. Unix	43
3. Principles of Programming Languages	76
4. Mathematical Foundations of Computer Science	96
5. Operating Systems	131
6. Automata Theory	146
7. Principles of Compiler Design	158
8. Computer Organization	171
9. Data Structures	203
10. Computer Graphics	224
11. System Software	235
12. Database Management Systems	242
13. Object Oriented Programming Using C++	250
14. Computer Networks	264
15. Software Engineering	272
16. SQL*PLUS, SQL, PL/SQL, Forms and Reports	279
<i>Appendix: Computer Science Question Paper for GATE 2005</i>	315
<i>Suggested Books for Reading</i>	333

Second Edition

MCOQs in COMPUTER SCIENCE

This book is designed for Computer Science students taking their GATE, GRE and other competitive examinations, e.g. examinations for PSUs and placement examinations for software firms. It can also act as a powerful self-evaluation tool for the students of Computer Science and Engineering, MCA, B.Sc. (Computer Science), BCA and PGDCA.

Updated With:

- ▶ Inclusion of a new chapter on Oracle covering SQL, PL/SQL, SQL*Plus, Reports and Forms.
- ▶ Expanded coverage of Principles of Programming Languages, Mathematical Foundations of Computer Science, Operating Systems and Data Structures.
- ▶ Over 280 new exercises plus many updated problems.
- ▶ A hundred more explanations to exercise-answers.

Key Features

- ▶ Over 1950 Multiple-Choice Questions to fully arm the student for competitive examinations.
- ▶ Includes answers to all questions.
- ▶ Provides a brief explanation for 620 chosen tricky questions.
- ▶ Includes questions from previous years' papers of the GATE examination, GRE's subject test in Computer Science and questions from the screening tests conducted by organizations for placement.
- ▶ Question Paper of GATE 2005 included.



Tata McGraw-Hill

Visit us at : www.tatamcgrawhill.com

ISBN 0-07-059356-6



9 780070 593565

Suggested Books for Reading

1. Aho and Ullman (1985), *Principles of Compiler Design*, Narosa.
2. Beek, L.L. (1985), *An Introduction to System Programming*, Addison Wesley.
3. Black, Ulyss (1987), *Computer Networks*, Prentice Hall.
4. Cohen, D.I.A. (1991), *Introduction to Computer Theory*, Wiley.
5. Das, Sumitabha (1993), *Unix System: Concepts and Applications*, Tata McGraw-Hill.
6. Date, C.J. (1981), *An Introduction to Database System*, Vol. 1. Narosa.
7. Donovan (1972), *Systems Programming*, Tata McGraw-Hill.
8. Hamacher, et al (1984), *Computer Organisation*, Tata McGraw-Hill.
9. Hancock, L. (1986), *C Primer*, Tata McGraw-Hill.
10. Harrington (1987), *Computer Graphics*, Tata McGraw-Hill.
11. Hayes, J.P. (1888), *Computer Architecture and Organisation*, Tata McGraw-Hill.
12. Hearn and Baker (1986), *Computer Graphics*, Prentice Hall.
13. Horowitz, E. (1984), *Fundamentals of Programming Languages*, Galgotia.
14. Kanetkar, Y. (1993), *Exploring C*, BPB.
15. Kelly, A., and I. Pohl (1992), *C by Dissection*, Benjamin/Cummings.
16. Koeing, A. (1989), *C Traps and Pitfalls*, Addison Wesley.
17. Korth and Silberschatz (1991), *Database Systems Concepts*, Tata McGraw-Hill.
18. Kruse R. (1987), *Data Structures and Program Design*, Prentice Hall.
19. Lafore, R. (1991), *Object Oriented Programming in Turbo C++*, Galgotia.
20. Liu, C.L. (1985), *Elements of Discrete Mathematics*, McGraw-Hill.
21. Mano, M. (1982), *Computer System Architecture*, Prentice-Hall.

Preface to the Second Edition

This book is primarily written for undergraduate students of computer science seeking admission to master's program in computer science through examinations like GATE and GRE (in computer science). It will also be helpful for those taking computer science tests conducted by some companies for recruitment. It contains more than 1800 questions from the core areas of computer science. The questions are grouped subject-wise.

The overwhelming response to the first edition of this book has inspired me to bring out this second edition which is a thoroughly revised and updated version of the first.

The book now has sixteen chapters. The first chapter deals with the programming language C that is still popular in spite of its age. The second chapter contains questions on UNIX, which has become popular due to its simple and easy-to-understand structure. In the third chapter, a variety of problems based on the principles of programming languages are discussed.

The fourth chapter, Mathematical Foundations of Computer Science, has been revamped. It has questions based on the mathematical principles that are vital to the better understanding of computer science. Numerous problems from operations research, numerical methods, matrices and determinants, permutations and combinations, probability and statistics, discrete math, calculus and theory of equations are included in this chapter. In almost all the other chapters also some revision has been effected and additional questions included.

A new chapter on Oracle that covers SQL, PL/SQL, SQL*Plus, FORMS and REPORTS has been added towards the end of the book. Also included is the Computer Science question paper for GATE 2005 as an appendix. This will help the students in the preparation of their GATE examination.

Every effort has been made to make this book error-free. I welcome all constructive criticism of the book.

TIMOTHY J WILLIAMS

Preface to the First Edition

This book of multiple choice questions has been compiled by taking into account the requirements of undergraduate students of Computer Science and Engineering. It contains more than 1600 questions that are carefully selected from the core subjects included in the curriculum of the major universities imparting computer education in our country.

A multipurpose book of this kind would not only serve the purposes of students appearing for various competitive examinations but would also expose professionals to a wide array of questions chosen from areas of contemporary relevance and interest.

The questions are grouped subject-wise, keeping in view the needs of individuals with various levels of expertise and background in computers. The book is ideal for students preparing for AGRE test in computer science as well as GATE and other similar exams. It is equally useful for students seeking placement in reputed firms as a good number of questions from the screening tests conducted by these organisations are included in the text.

The book is divided into fifteen chapters. The first chapter deals with the programming language C which is notable for the power and freedom offered to the users. Kernighan and Ritchie have made the language accessible to all by bestowing low-level features in an otherwise, high level language. But, even ace programmers are often encountered with difficulties while operating C language. Hence a large number of questions in this chapter are devoted to make readers aware of the potential problems incurred while tackling C.

The second chapter contains questions on UNIX & C, a powerful combination made popular due to the simple and easy-to-understand structure. In third chapter, a variety of problems based on the principles of programming languages with a special emphasis on PASCAL are discussed.

The fourth chapter dwells on the questions relating to the mathematical principles that are vital to the better understanding of computer science. Numerous problems on operations research, numerical methods, matrices and determinants, permutations and combinations, probability and statistics, discrete maths, calculus, and theory of equations are included in this chapter. Various relevant topics in computer science are covered systematically in rest of the chapters.

The process of analysis and organised reasoning is vital to programming. I believe that the questions included in this book will sharpen the logical thinking and reasoning of the readers which would help them a great deal in mastering the art of programming.

Every effort has been made to make the book, simple and error-free. I welcome any constructive criticism of the book and will be grateful for any honest appraisal from the readers.

TIMOTHY J WILLIAMS

Statement for Linked Answer Questions 84a and 84b

We are given 9 tasks T_1, T_2, \dots, T_9 . The execution of each task requires one unit of time. We can execute one task at a time. Each task T_i has a profit P_i and a deadline d_i . Profit P_i is earned if the task is completed before the end of the d_i^{th} unit of time.

Task	T_1	T_2	T_3	T_4	T_5	T_6	T_7	T_8	T_9
Profit	15	20	30	18	18	10	23	16	25
Deadline	7	2	5	3	4	5	2	7	3

Q.84a Are all tasks completed in the schedule that gives maximum profit?

- (A) All tasks are completed (B) T_1 and T_6 are left out
(C) T_1 and T_8 are left out (D) T_4 and T_6 are left out

Q.84b What is the maximum profit earned?

- (A) 147 (B) 165 (C) 167 (D) 175

Statement for Linked Answer Questions 85a and 85b

Consider the following floating point format.



Mantissa is a pure fraction in sign-magnitude form.

Q.85a The decimal number 0.239×2^{13} has the following hexadecimal representation (without normalization and rounding off):

- (A) 0D 24 (B) 0D 4D (C) 4D 0D (D) 4D 3D

Q.85b The normalized representation for the above format is specified as follows. The mantissa has an implicit 1 preceding the binary (radix) point. Assume that only 0's are padded in while shifting a field.

The normalized representation of the above (0.239×2^{13}) is:

- (A) 0A 20 (B) 11 34 (C) 49 D0 (D) 4A E8

Q.82a The edge e must definitely belong to:

- (A) the minimum weighted spanning tree of G
- (B) the weighted shortest path from s to t
- (C) each path from s to t
- (D) the weighted longest path from s to t

Q.82b Let the weight of an edge e denote the congestion on that edge. The congestion on a path is defined to be the maximum of the congestions on the edges of the path. We wish to find the path from s to t having minimum congestion. Which one of the following paths is always such a path of minimum congestion?

- (A) a path from s to t in the minimum weighted spanning tree
- (B) a weighted shortest path from s to t
- (C) an Euler walk from s to t
- (D) a Hamiltonian path from s to t

Statement for Linked Answer Questions 83a and 83b

Consider the following expression grammar. The semantic rules for expression evaluation are stated next to each grammar production.

$E \rightarrow \text{number}$	$E.\text{val} = \text{number val}$
$E \rightarrow '+' E$	$E^{(1)}.\text{val} = E^{(2)}.\text{val} + E^{(3)}.\text{val}$
$E \rightarrow ' \times ' E$	$E^{(1)}.\text{val} = E^{(2)}.\text{val} \times E^{(3)}.\text{val}$

Q.83a The above grammar and the semantic rules are fed to a *yacc* tool (which is an LALR (1) parser generator) for parsing and evaluating arithmetic expressions. Which one of the following is true about the action of *yacc* for the given grammar?

- (A) It detects recursion and eliminates recursion
- (B) It detects *reduce-reduce* conflict, and resolves
- (C) It detects *shift-reduce* conflict, and resolves the conflict in favor of a *shift* over a *reduce* action
- (D) It detects *shift-reduce* conflict, and resolves the conflict in favor of a *reduce* over a *shift* action

Q.83b Assume the conflicts in Part (a) of this question are resolved and an LALR(1) parser is generated for parsing arithmetic expressions as per the given grammar. Consider an expression $3 \times 2 + 1$. What precedence and associativity properties does the generated parser realize?

- (A) Equal precedence and left associativity; expression is evaluated to 7
- (B) Equal precedence and right associativity; expression is evaluated to 9
- (C) Precedence of \times is higher than that of $+$, and both operators are left associative; expression is evaluated to 7
- (D) Precedence of $+$ is higher than that of \times , and both operators are left associative; expression is evaluated to 9

Acknowledgements

All praise, laud and honor to Jesus Christ for His amazing grace and guidance.

It is Prof. Kuppaswami of Pondicherry University who unraveled my latent and dormant potential of writing a book of this kind. Special thanks to him. This book is not the outcome of my effort alone. I am indebted to Mr. Selvaradjou, Dr. Antony, Dr. Sukumaran and my ex-colleagues at Pondicherry Engineering College for their contribution and cooperation.

Thanks to Ms Vibha Mahajan, Mr Jacob Alexander, Ms Mini Narayanan, Ms Anjali Razdan and others at Tata McGraw-Hill for their efforts and cooperation while working on this revised edition.

I would have thanked Hannah, had it been an Indian tradition to thank one's own wife.

TIMOTHY J WILLIAMS

Chapter 1

Programming with C

- Choose the correct statement.
 - Use of `goto` enhances the logical clarity of a code.
 - Use of `goto` makes the debugging task easier.
 - Use `goto` when you want to jump out of a nested loop.
 - Never use `goto`.
- Which is true of conditional compilation?
 - It is taken care of by the compiler.
 - It is setting the compiler option conditionally.
 - It is compiling a program based on a condition.
 - It is taken care of by the pre-processor.
- C was primarily developed as a
 - systems programming language
 - general purpose language
 - data processing language
 - none of the above
- C is a
 - high level language
 - low level language
 - high level language with some low level features.
 - low level language with some high level features.
- Even if a particular implementation doesn't limit the number of characters in an identifier, it is advisable to be concise because
 - chances of typographic errors are less
 - it may be processed by assembler, loaders, etc., which may have their own rules that may contradict the language rules

The ALU, the bus and all the registers in the data path are of identical size. All operations including incrementation of the PC and the GPRs are to be carried out in the ALU. Two clock cycles are needed for memory read operation—the first one for loading address in the MAR and the next one for loading data from the memory bus into the MDR.

Q.79 The instruction “add R0, R1” has the register transfer interpretation $R0 \leftarrow R0 + R1$. The minimum number of clock cycles needed for execution cycle of this instruction is:

- (A) 2 (B) 3 (C) 4 (D) 5

Q.80 The instruction “call Rn, sub” is a two word instruction. Assuming that PC is incremented during the fetch cycle of the first word of the instruction, its register transfer interpretation is

$$Rn \leftarrow PC + 1;$$

$$PC \leftarrow M[PC];$$

The minimum number of CPU clock cycles needed during the execution cycle of this instruction is:

- (A) 2 (B) 3 (C) 4 (D) 5

LINKED ANSWER QUESTIONS: Q.81A TO Q.85B CARRY TWO MARKS EACH

Statement for Linked Answer Questions 81a and 81b

Consider the following C-function:

```
double foo (int n) {
    int i;
    double sum;
    if (n == 0) return 1.0;
    else {
        sum = 0.0;
        for (i = 0; i < n; i++)
            sum += foo(i);
        return sum;
    }
}
```

Q.81a The space complexity of the above function is:

- (A) $O(1)$ (B) $O(n)$ (C) $O(n!)$ (D) $O(n^n)$

Q.81b Suppose we modify the above function `foo ()` and store the values of `foo (i)`, $0 \leq i < n$, as and when they are computed. With this modification, the time complexity for function `foo ()` is significantly reduced. The space complexity of the modified function would be:

- (A) $O(1)$ (B) $O(n)$ (C) $O(n^2)$ (D) $O(n!)$

Statement for Linked Answer Questions 82a and 82b

Let s and t be two vertices in a undirected graph $G = (V, E)$ having distinct positive edge weights. Let $[X, Y]$ be a partition V such that $s \in X$ and $t \in Y$. Consider the edge e having the minimum weight amongst all those edges that have one vertex in X and one vertex in Y .

A	C
2	4
3	4
4	3
5	2
7	2
9	5
6	4

The set of all tuples that must be additionally deleted to preserve referential integrity when the tuple (2, 4) is deleted is:

- (A) (3, 4) and (6, 4)
- (B) (5, 2) and (7, 2)
- (C) (5, 2), (7, 2) and (9, 5)
- (D) (3, 4), (4, 3) and (6, 4)

Q.77 The relation **book** (title, price) contains the titles and prices of different books. Assuming that no two books have the same price, what does the following SQL query list?

```

select title
from book as B
where (select count (*)
      from book as A
      where T. price > B.price) < 5
    
```

- (A) Titles of the four most expensive books
- (B) Title of the fifth most inexpensive book
- (C) Title of the fifth most expensive book
- (D) Titles of the five most expensive books

Q.78 Consider a relation scheme R = (A, B, C, D, E, H) on which the following functional dependencies hold: {A → B, BC → D, E → C, D → A}. What are the candidate keys of R?

- (A) AE, BE
- (B) AE, BE, DE
- (C) AEH, BEH, BCH
- (D) AEH, BEH, DEH

COMMON DATA QUESTIONS

Common Data for Questions 79, 80

Consider the following data path of a CPU.

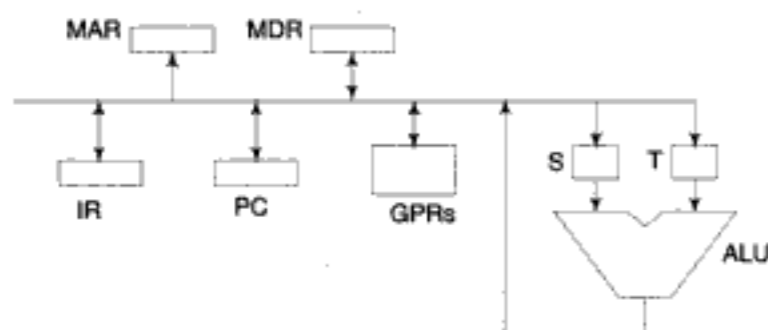

- (c) by being concise, one can be mnemonic
- (d) none of the above

*6. The minimum number of temporary variables needed to swap the contents of two variables is

- (a) 1
- (b) 2
- (c) 3
- (d) 0

7. The purpose of the following program fragment

```

b = s + b;
s = b - s;
b = b - s;
    
```

where s, b are two integers is to

- (a) transfer the contents of s to b
- (b) transfer the contents of b to s
- (c) exchange (swap) the contents of s and b
- (d) negate the contents of s and b

8. Consider the function

```

find(int x, int y)
{return(( x < y) ? 0 : ( x - y));}
    
```

Let a, b be two non-negative integers. The call find(a, find(a, b)) can be used to find the

- (a) maximum of a, b
- (b) positive difference of a, b
- (c) sum of a, b
- (d) minimum of a, b

9. Let a, b be two non-negative integers. Which of the following calls, finds the positive difference of a and b?

- (a) find(a,b) + find(b,a)
- (b) find(a,find(a,b))
- (c) a + find(a,b)
- (d) b + find(a,b)

10. If integer needs two bytes of storage, then maximum value of an unsigned integer is

- (a) $2^{16} - 1$
- (b) $2^{15} - 1$
- (c) 2^{16}
- (d) 2^{15}

*11. If integer needs two bytes of storage, then maximum value of a signed integer is

- (a) $2^{16} - 1$
- (b) $2^{15} - 1$
- (c) 2^{16}
- (d) 2^{15}

*12. printf("%d", printf("tim"));

- (a) results in a syntax error
- (b) outputs tim3
- (c) outputs garbage
- (d) prints tim and terminates abruptly

*13. If abc is the input, then the following program fragment

```

char x, y, z;
printf("%d", scanf ("%c%c%c", &x, &y, &z));
    
```

- (a) a syntax error
- (b) a fatal error
- (c) segmentation violation
- (d) printing of 3

*14. Consider the statements

```

putchar(getchar());
putchar(getchar());
    
```

If
a
b

is the input, the output will be

- (a) an error message (b) this can't be the input
(c) ab (d) a b

15. Let a, b be two positive integers. Which of the following options correctly relates / and %?

- (a) $b = (a/b) * b + a \% b$ (b) $a = (a/b) * b + a \% b$
(c) $b = (a \% b) * b + a / b$ (d) $a = (a \% b) * b + a / b$

16. Literal means

- (a) a string (b) a string constant (c) a character (d) an alphabet

17. Length of the string "correct" is

- (a) 7 (b) 8
(c) 6 (d) implementation dependent.

18. Which of the following are true regardless of the implementation?

- (a) `sizeof(int)` is not less than `sizeof(long)`
(b) `sizeof(short)` equals `sizeof(int)`
(c) `sizeof(int)` equals `sizeof(unsigned)`
(d) `sizeof(double)` is not less than `sizeof(float)`

19. Coercion

- (a) takes place across an assignment operator.
(b) takes place if an operator has operands of different data types.
(c) means casting.
(d) none of the above.

20. Choose the correct statements.

- (a) Casting refers to implicit type conversion.
(b) Coercion refers to implicit type conversion.
(c) Casting refers to explicit type conversion.
(d) Coercion refers to explicit type conversion.

21. Consider the following program fragment

```
char c = 'a';
while (c++ <= 'z')
    putchar(xxx);
```

If the required output is abcdefghijklmnopqrstuvwxyz, then xxx should be

- (a) c (b) c++ (c) c-1 (d) -c

22. Which of the following comments are true?

- (a) C provides no input-output features.
(b) C provides no file access features.
(c) C borrowed most of its ideas from BCPL.
(d) C provides no features to manipulate composite objects.

Q.69 A device with data transfer rate 10 kB/sec is connected to a CPU. Data is transferred byte-wise. Let the interrupt overhead by 4 μ sec. The byte transfer time between the device interface register and CPU or memory is negligible. What is the minimum performance gain of operating the device under interrupt mode over operating it under program controlled mode?

- (A) 15 (B) 25 (C) 35 (D) 45

Q.70 Consider a disk drive with the following specifications:

16 surfaces, 512 tracks/surface, 512 sectors/track, 1 KB/sector, rotation speed 3000 rpm. The disk is operated in cycle stealing mode whereby whenever one 4 byte word is ready it is sent to memory; similarly, for writing, the disk interface reads a 4 byte word from the memory in each DMA cycle. Memory cycle time is 40 nsec. The maximum percentage of time that the CPU gets blocked during DMA operation is:

- (A) 10 (B) 25 (C) 40 (D) 50

Q.71 Suppose n processes, P_1, \dots, P_n share m identical resource units, which can be reserved and released one at a time. The maximum resource requirement of process P_i is s_i , where $s_i > 0$. Which one of the following is a sufficient condition of ensuring that deadlock does not occur?

- (A) $\forall i, s_i < m$ (B) $\forall i, s_i < n$ (C) $\sum_{i=1}^n s_i < (m+n)$ (D) $\sum_{i=1}^n s_i < (m * n)$

Q.72 Consider the following code fragment:

```
if (fork ( ) == 0)
    { a = a + 5; printf (" % d, % d\n", a, &a); }
else { a = a - 5; printf ("% d, % d\n", a, &a); }
```

Let u, v be the values printed by the parent process, and x, y be the values printed by the child process. Which one of the following is TRUE?

- (A) $u = x + 10$ and $v = y$ (B) $u = x + 10$ and $v \neq y$
(C) $u + 10 = x$ and $v = y$ (D) $u + 10 = x$ and $v \neq y$

Q.73 In a packet switching network, packets are routed from source to destination along a single path having two intermediate nodes. If the message size is 24 bytes and each packet contains a header 3 bytes, then the optimum packet size is:

- (A) 4 (B) 6 (C) 7 (D) 9

Q.74 Suppose the round trip propagation delay for a 10 Mbps Ethernet having 48-bit jamming signal is 46.4 μ s. The minimum frame size is:

- (A) 94 (B) 416 (C) 464 (D) 512

Q.75 Let E_1 and E_2 be two entities in an E/R diagram with simple single-valued attributes. R_1 and R_2 are two relationships between E_1 and E_2 , where R_1 is one-to-many and R_2 is many-to-many. R_1 and R_2 do not have any attributes of their own. What is the minimum number of tables required to represent this situation in the relational model?

- (A) 2 (B) 3 (C) 4 (D) 5

Q.76 The following table has two attributes A and C where A is the primary key and C is the foreign key referencing A with on-delete cascade.

(A) $00 \rightarrow 11 \rightarrow 01$ (B) $00 \rightarrow 11$ (C) $00 \rightarrow 10 \rightarrow 01 \rightarrow 11$ (D) $00 \rightarrow 11 \rightarrow 01 \rightarrow 10$

Q.65 Consider a three word machine instruction

ADD A[R0], @B

The first operand (destination) "A[R0]" uses indexed addressing mode with R0 as the index register. The second operand (source) "@B" uses indirect addressing mode. A and B are memory addresses residing at the second and the third words, respectively. The first word of the instruction specifies the opcode, the index register designation and the source and destination addressing modes. During execution of ADD instruction, the two operands are added and stored in the destination (first operand).

The number of memory cycles needed during the execution cycle of the instruction is:

(A) 3 (B) 4 (C) 5 (D) 6

Q.66 Match each of the high level language statements given on the left hand side with the most natural addressing mode from those listed on the right hand side.

- | | |
|----------------------------|----------------------------|
| (1) A [I] = B [J]; | (a) Indirect addressing |
| (2) while (* A++); | (b) Indexed addressing |
| (3) int temp = *x; | (c) Autoincrement |
| (A) (1, c), (2, b), (3, a) | (B) (1, a), (2, c), (3, b) |
| (C) (1, b), (2, c), (3, a) | (D) (1, a), (2, b), (3, c) |

Q.67 Consider a direct mapped cache of size 32 kB with block size 32 bytes. The CPU generates 32 bit addresses. The number of bits needed for cache indexing and the number of tag bits are respectively:

(A) 10, 17 (B) 10, 22 (C) 15, 17 (D) 5, 17

Q.68 A 5 stage pipelined CPU has the following sequence of stages:

IF—Instruction fetch from instruction memory.

RD—Instruction decode and register read.

EX—Execute: ALU operation for data and address computation.

MA—Data memory access—for write access, the register read at RD stage is used.

WB—Register write back.

Consider the following sequence of instructions:

I₁: L R0, loc 1; R0 <= M [loc 1]I₂: A R0, R0; R0 <= R0 + R0I₃: S R2, R0; R2 <= R2 - R0

Let each stage take one clock cycle.

What is the number of clock cycles taken to complete the above sequence of instructions starting from the fetch of I₁?

(A) 8 (B) 10 (C) 12 (D) 15

*23. If y is of integer type then the expressions

 $3 * (y - 8) / 9$ and $(y - 8) / 9 * 3$

- (a) must yield the same value (b) must yield different values
(c) may or may not yield the same value (d) none of the above

24. If y is of integer type then the expressions

 $3 * (y - 8) / 9$ and $(y - 8) / 9 * 3$

yield the same value if

- (a) y is an even number (b) y is an odd number
(c) y - 8 is an integral multiple of 9 (d) y - 8 is an integral multiple of 3

25. Integer division results in

- (a) truncation (b) rounding (c) overflow (d) none of the above

26. Which of the following comments about EOF are true?

- (a) Its value is defined within `stdio.h`.
(b) Its value is implementation dependent.
(c) Its value can be negative.
(d) Its value should not equal the integer equivalent of any character.

*27. The value of an automatic variable that is declared but not initialized will be

- (a) 0 (b) -1 (c) unpredictable (d) none of the above

28. Choose the correct statements.

- (a) An identifier may start with an underscore.
(b) An identifier may end with an underscore.
(c) IF is a valid identifier.
(d) The number of significant characters in an identifier is implementation dependent.

29. Choose the correct statements.

- (a) Constant expressions are evaluated at compile time.
(b) String constants can be concatenated at compile time.
(c) Size of array must be known at compile time.
(d) None of the above.

30. The `const` feature can be applied to

- (a) an identifier (b) an array
(c) an array argument (d) none of the above

31. Which of the following operators takes only integer operands?

- (a) + (b) * (c) / (d) %

32. In an expression involving `||` operator, evaluation

- (a) will be stopped if one of its components evaluates to false
(b) will be stopped if one of its components evaluates to true
(c) takes place from right to left
(d) takes place from left to right

33. The statement
- ```

if(myPtr != NULL)
 *myPtr = NULL;
else
 *myPtr = NULL;

```
- has the same effect as the statement(s)
- (a) `if(myPtr) *myPtr = NULL; else *myPtr = NULL;`
  - (b) `*myPtr = NULL;`
  - (c) `if(!myPtr) *myPtr = NULL; else *myPtr = NULL;`
  - (d) `if(myPtr == NULL) *myPtr = NULL; else *myPtr = NULL;`

34. Pick the operators that associate from the left.

- (a) +
- (b) ,
- (c) =
- (d) <

35. Pick the operators that associate from the right.

- (a) ?:
- (b) +=
- (c) =
- (d) !=

36. The operators `.`, `||`, `<`, `=`, if arranged in the ascending order of precedence reads

- (a) `.`, `||`, `<`, `=`
- (b) `=`, `<`, `||`, `.`
- (c) `=`, `||`, `<`, `.`
- (d) `<`, `||`, `=`, `.`

37. Pick the operators whose meaning is context dependent.

- (a) \*
- (b) #
- (c) &
- (d) No such operator exists.

38. Pick the operators that associate from the left.

- (a) &&
- (b) ||
- (c) ?:
- (d) ,

\*39. The following code fragment

```

int x, y = 2, z, a;
x = (y *= 2) + (z = a = y);
printf ("%d", x);

```

- (a) prints 8
- (b) prints 6
- (c) prints 6 or 8 depending on the compiler implementation
- (d) is syntactically wrong

\*40. If `n` has the value 3, then the output of the statement `printf("%d %d", n++, ++n);`

- (a) is 3 5
- (b) is 4 5
- (c) is 4 4
- (d) is implementation dependent

41. `x -= y + 1;` means

- (a) `x = x - y + 1`
- (b) `x = -x - y - 1`
- (c) `x = -x + y + 1`
- (d) `x = x - y - 1`

42. Which of the following comments about the `++` operator are correct?

- (a) It is a unary operator.
- (b) The operand can come before or after the operator.

Consider the following timing diagram. Let  $A_i$  represent the logic level on the line A in the  $i$ -th clock period.

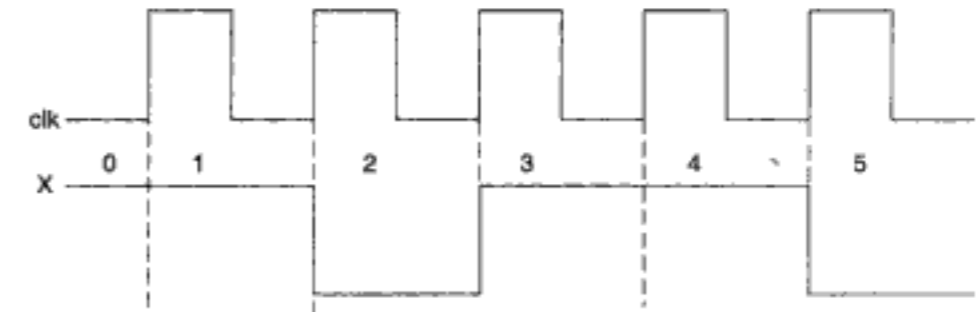

Let  $A'$  represent the complement of A. The correct output sequence on Y over the clock periods 1 through 5 is:

- (A)  $A_0 A_1 A_1' A_3 A_4$
- (B)  $A_0 A_1 A_2' A_3 A_4$
- (C)  $A_1 A_2 A_2' A_3 A_4$
- (D)  $A_1 A_2' A_3 A_4 A_5'$

Q.63 The following diagram represents a finite state machine which takes as input a binary number from the least significant bit.



Which one of the following is TRUE?

- (A) It computes 1's complement of the input number
- (B) It computes 2's complement of the input number
- (C) It increments the input number
- (D) It decrements the input number

Q.64 Consider the following circuit.

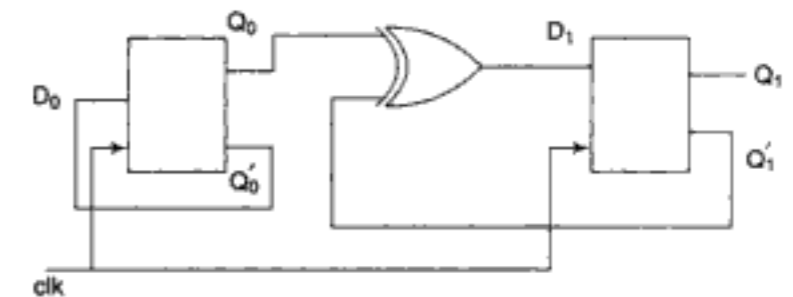

The flip-flops are positive edge triggered D FFs. Each state is designated as a two bit string  $Q_0Q_1$ . Let the initial state be 00. The state transition sequence is:

- (A)  $L_1$  is a deterministic CFL (B)  $L_2$  is a deterministic CFL  
 (C)  $L_3$  is a CFL, but not a deterministic CFL (D)  $L_3$  is a deterministic CFL

**Q.58** Consider the following two problems on undirected graphs:

$\alpha$ : Given  $G(V, E)$ , does  $G$  have an independent set of size  $|V| - 4$ ?

$\beta$ : Given  $G(V, E)$ , does  $G$  have an independent set of size 5?

Which one of the following is TRUE?

- (A)  $\alpha$  is in P and  $\beta$  is NP-complete (B)  $\alpha$  is NP-complete and  $\beta$  is in P  
 (C) Both  $\alpha$  and  $\beta$  are NP-complete (D) Both  $\alpha$  and  $\beta$  are in P

**Q.59** Consider the grammar:

$$E \rightarrow E + n \mid E \times n \mid n$$

For a sentence  $n + n \times n$ , the handles in the right-sentential form of the reduction are:

- (A)  $n, E + n$  and  $E + n \times n$  (B)  $n, E + n$  and  $E + E \times n$   
 (C)  $n, n + n$  and  $n + n \times n$  (D)  $n, E + n$  and  $E \times n$

**Q.60** Consider the grammar:

$$S \rightarrow (S) \mid a$$

Let the number of states in SLR (1), LR (1) and LALR (1) parsers for the grammar be  $n_1, n_2$  and  $n_3$  respectively. The following relationship holds good:

- (A)  $n_1 < n_2 < n_3$  (B)  $n_1 = n_3 < n_2$  (C)  $n_1 = n_2 = n_3$  (D)  $n_1 \geq n_3 \geq n_2$

**Q.61** Consider number 3 of the following C-program.

```
int main () { /* Line 1 */
int I, N; /* Line 2 */
 fro (I = 0, I < N, I ++); /* Line 3 */
}
```

Identify the compiler's response about this line while creating the object-module:

- (A) No compilation error (B) Only a lexical error  
 (C) Only syntactic errors (D) Both lexical and syntactic errors

**Q.62** Consider the following circuit involving a positive edge triggered D FF.

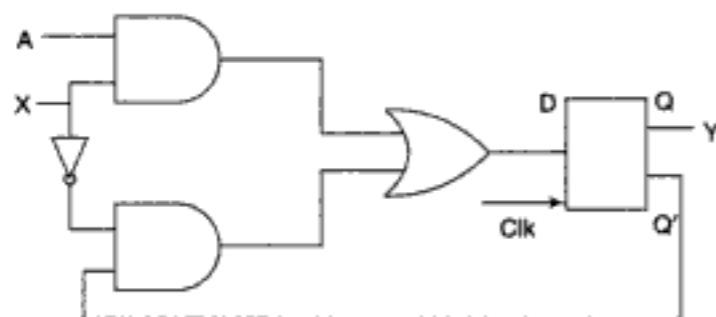

- (c) It cannot be applied to an expression.  
 (d) It associates from the right.

**43.** In standard C, trigraphs in the source program are translated

- (a) before the lexical analysis  
 (b) after the syntax analysis  
 (c) before the recognition of escape characters in strings  
 (d) during the intermediate code generation phase

**\*44.** The expression  $5 - 2 - 3 * 5 - 2$  will evaluate to 18, if

- (a)  $-$  is left associative and  $*$  has precedence over  $-$   
 (b)  $-$  is right associative and  $*$  has precedence over  $-$   
 (c)  $-$  is right associative and  $-$  has precedence over  $*$   
 (d)  $-$  is left associative and  $-$  has precedence over  $*$

**45.** `printf("%c", 100);`

- (a) prints 100 (b) prints the ASCII equivalent of 100  
 (c) prints garbage (d) none of the above

**\*46.** The program fragment

```
int i = 263;
putchar(i);
```

- (a) prints 263 (b) prints the ASCII equivalent of 263  
 (c) rings the bell (d) prints garbage

**47.** Which of the following comments regarding the reading of a string, using `scanf` (with `%s` option) and `gets`, is true?

- (a) Both can be used interchangeably.  
 (b) `scanf` is delimited by end of line, while `gets` is not.  
 (c) `scanf` is delimited by blank space, while `gets` is not.  
 (d) None of the above.

**\*48.** The following statement

```
printf("%f", 9/5);
```

prints

- (a) 1.8 (b) 1.0 (c) 2.0 (d) none of the above

**49.** The statement

```
printf("%f", (float)9/5);
```

prints

- (a) 1.8 (b) 1.0 (c) 2.0 (d) none of the above

**\*50.** Which of the following are not keywords in C?

- (a) `printf` (b) `main` (c) `IF` (d) none of the above

**\*51.** The following program fragment

```
unsigned i = 1;
int j = -4;
printf("%u", i + j);
```

prints



- (a) garbage
- (b) -3
- (c) an integer that changes from machine to machine
- (d) none of the above

\*52. If the following program fragment (assume negative numbers are stored in 2's complement form)

```
unsigned i = 1;
int j = -4;
printf("%u", i + j);
```

prints x, then printf("%d", 8 \* sizeof(int));  
outputs an integer that is same as (log in the answers are to the base two)

- (a) an unpredictable value
- (b)  $8 * \log(x+3)$
- (c)  $\log(x+3)$
- (d) none of the above

53. Choose the statements that are syntactically correct.

- (a) /\* Is /\* this a valid \*/ comment \*/
- (b) for(;;);
- (c) return;
- (d) return(5+2);

\*54. The following program fragment

```
for(i = 3; i < 15; i += 3);
printf("%d", i);
```

results in

- (a) a syntax error
- (b) an execution error
- (c) printing of 12
- (d) printing of 15

\*55. The following program fragment

```
for (i = 1; i < 5; ++i)
if (i == 3) continue;
else printf("%d ", i);
```

results in the printing of

- (a) 1 2 4 5
- (b) 1 2 4
- (c) 2 4 5
- (d) none of the above

56. The following program fragment

```
if (a = 0)
printf("a is zero");
else
printf("a is not zero");
```

results in the printing of

- (a) a is zero
- (b) a is not zero
- (c) nothing
- (d) garbage

Q.53 Consider the machine M:

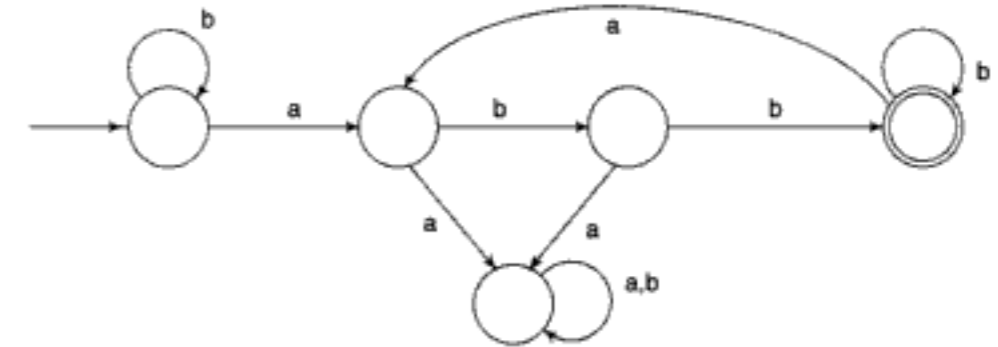

The language recognized by M is:

- (A)  $\{w \in \{a,b\}^* \mid \text{every } a \text{ in } w \text{ is followed by exactly two } b\text{'s}\}$
- (B)  $\{w \in \{a,b\}^* \mid \text{every } a \text{ in } w \text{ is followed by at least two } b\text{'s}\}$
- (C)  $\{w \in \{a,b\}^* \mid w \text{ contains the substring 'abb'}\}$
- (D)  $\{w \in \{a,b\}^* \mid w \text{ does not contain 'aa' as a substring}\}$

Q.54 Let  $N_f$  and  $N_p$  denote the classes of languages accepted by non-deterministic finite automata and non-deterministic push-down automata, respectively. Let  $D_f$  and  $D_p$  denote the classes of languages accepted by deterministic finite automata and deterministic push-down automata, respectively. Which one of the following is TRUE?

- (A)  $D_f \subset N_f$  and  $D_p \subset N_p$
- (B)  $D_f \subset N_f$  and  $D_p = N_p$
- (C)  $D_f = N_f$  and  $D_p = N_p$
- (D)  $D_f = N_f$  and  $D_p \subset N_p$

Q.55 Consider the languages:

$$L_1 = \{a^n b^n c^m \mid n, m > 0\} \text{ and } L_2 = \{a^n b^m c^m \mid n, m > 0\}$$

Which one of the following statements is FALSE?

- (A)  $L_1 \cap L_2$  is a context-free language
- (B)  $L_1 \cup L_2$  is a context-free language
- (C)  $L_1$  and  $L_2$  are context-free languages
- (D)  $L_1 \cap L_2$  is a context-sensitive language

Q.56 Let  $L_1$  be a recursive language, and let  $L_2$  be recursively enumerable but not a recursive language. Which one of the following is TRUE?

- (A)  $\bar{L}_1$  is recursive and  $\bar{L}_2$  is recursively enumerable
- (B)  $\bar{L}_1$  is recursive and  $\bar{L}_2$  is not recursively enumerable
- (C)  $\bar{L}_1$  and  $\bar{L}_2$  are recursively enumerable
- (D)  $\bar{L}_1$  is recursively enumerable and  $\bar{L}_2$  is recursive

Q.57 Consider the languages:

$$L_1 = \{ww^R \mid w \in \{0,1\}^*\}$$

$$L_2 = \{w \# w^R \mid w \in \{0,1\}^*\}, \text{ where } \# \text{ is a special symbol}$$

$$L_3 = \{ww \mid w \in \{0,1\}^*\}$$

Which one of the following is TRUE?

Q.47 Which one of the following graphs is NOT planar?

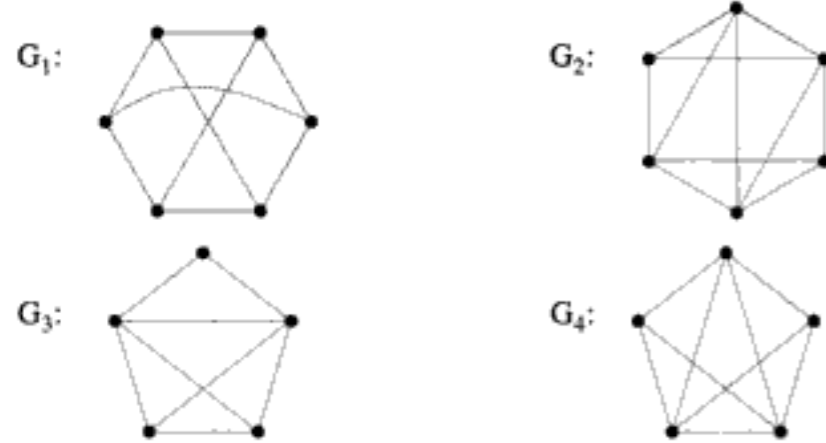

- (A)  $G_1$  (B)  $G_2$  (C)  $G_3$  (D)  $G_4$

Q.48 Consider the following system of equations in three real variables  $x_1, x_2$  and  $x_3$ :

$$\begin{aligned} 2x_1 - x_2 + 3x_3 &= 1 \\ 3x_1 + 2x_2 + 5x_3 &= 2 \\ -x_1 + 4x_2 + x_3 &= 3 \end{aligned}$$

This system of equations has

- (A) no solution  
(B) a unique solution  
(C) more than one but a finite number of solutions  
(D) an infinite number of solutions

Q.49 What are the eigen values of the following  $2 \times 2$  matrix?

$$\begin{bmatrix} 2 & -1 \\ -4 & 5 \end{bmatrix}$$

- (A) -1 and 1 (B) 1 and 6 (C) 2 and 5 (D) 4 and -1

Q.50 Let  $G(x) = 1/(1-x)^2 = \sum_{i=0}^{\infty} g(i)x^i$ , where  $|x| < 1$ . What is  $g(i)$ ?

- (A)  $i$  (B)  $i + 1$  (C)  $2i$  (D)  $2^i$

Q.51 Box  $P$  has 2 red balls and 3 blue balls and box  $Q$  has 3 red balls and 1 blue ball. A ball is selected as follows: (i) select a box (ii) choose a ball from the selected box such that each ball in the box is equally likely to be chosen. The probabilities of selecting boxes  $P$  and  $Q$  are  $1/3$  and  $2/3$ , respectively. Given that a ball selected in the above process is a red ball, the probability that it came from the box  $P$  is:

- (A)  $4/19$  (B)  $5/19$  (C)  $2/9$  (D)  $19/30$

Q.52 A random bit string of length  $n$  is constructed by tossing a fair coin  $n$  times and setting a bit to 0 or 1 depending on outcomes head and tail, respectively. The probability that two such randomly generated strings are not identical is:

- (A)  $1/2^n$  (B)  $1 - 1/n$  (C)  $1/n!$  (D)  $1 - 1/2^n$

57. The following program fragment

```
if(a = 7)
 printf("a is seven");
else
 printf("a is not seven");
```

results in the printing of

- (a) a is seven (b) a is not seven  
(c) nothing (d) garbage

\*58. The following program fragment

```
int k = -7;
printf("%d", 0 < !k);
```

- (a) prints 0 (b) prints a non-zero value  
(c) is illegal (d) prints an unpredictable value

59. The following loop

```
for(putchar('c'); putchar('a'); putchar('r'))
 putchar('t');
```

outputs

- (a) a syntax error (b) cartrt  
(c) catrat (d) catratratrat...

60. The following loop

```
for(i = 1, j = 10; i < 6; ++i, --j)
 printf("%d %d ", i, j);
```

prints

- (a) 1 10 2 9 3 8 4 7 5 6 (b) 1 2 3 4 5 10 9 8 7 6  
(c) 1 1 1 1 1 9 9 9 9 9 (d) none of the above

61. The following program fragment

```
int a = 4, b = 6;
printf("%d", a == b);
```

- (a) outputs an error message (b) prints 0  
(c) prints 1 (d) none of the above

62. The following program fragment

```
int a = 4, b = 6;
printf("%d", a != b);
```

- (a) outputs an error message (b) prints 0  
(c) prints 1 (d) none of the above

63. The following program fragment

```
int a = 4, b = 6;
printf("%d", a = b);
```

- (a) outputs an error message (b) prints 0  
(c) prints 1 (d) none of the above

64. A possible output of the following program fragment

```
for(i = getchar();; i = getchar())
 if(i == 'x') break;
 else putchar(i);
```

is

- (a) mi                      (b) mix                      (c) mixx                      (d) none of the above

65. The following program

```
main()
{
 int i = 5;
 if (i == 5) return;
 else printf("i is not five");
 printf("over");
}
```

results in

- (a) a syntax error                      (b) an execution error  
(c) printing of over                      (d) execution termination, without printing anything

\*66. The following program fragment

```
int i = 5;
do {putchar(i + 100); printf("%d", i--);}
while(i);
```

results in the printing of

- (a) i5h4g3f2el                      (b) i4h3g2fle0  
(c) an error message                      (d) none of the above

\*67. The following program fragment

```
int i = 107, x = 5;
printf((x > 7)? "%d": "%c", i);
```

results in

- (a) an execution error                      (b) a syntax error  
(c) printing of k                      (d) none of the above

\*68. Replacing > by < in the previous question results in

- (a) printing of 107                      (b) a syntax error  
(c) printing of k                      (d) none of the above.

\*69. The following loop

```
while(printf("%d", printf("az")))
 printf("by");
```

- (a) prints azbybybyby...                      (b) prints azbyazbyazbyazby...  
(c) results in a syntax error                      (d) none of the above

- (B)  $\forall (x) [\text{teacher}(x) \rightarrow \exists (y) [\text{student}(y) \wedge \text{likes}(y, x)]]$   
(C)  $\exists (y) \forall (x) [\text{teacher}(x) \rightarrow [\text{student}(y) \wedge \text{likes}(y, x)]]$   
(D)  $\forall (x) [\text{teacher}(x) \wedge \exists (y) [\text{student}(y) \rightarrow \text{likes}(y, x)]]$

Q.42 Let R and S be any two equivalence relations on a non-empty set A. Which one of the following statements is TRUE?

- (A)  $R \cup S$ ,  $R \cap S$  are both equivalence relations  
(B)  $R \cup S$  is an equivalence relation  
(C)  $R \cap S$  is an equivalence relation  
(D) Neither  $R \cup S$  nor  $R \cap S$  is an equivalence relation

Q.43 Let  $f: B \rightarrow C$  and  $g: A \rightarrow B$  be two functions and let  $h = f \circ g$ . Given that  $h$  is an onto function which one of the following is TRUE?

- (A)  $f$  and  $g$  should both be onto functions  
(B)  $f$  should be onto but  $g$  need not be onto  
(C)  $g$  should be onto but  $f$  need not be onto  
(D) both  $f$  and  $g$  need not be onto

Q.44 What is the minimum number of ordered pairs of non-negative numbers that should be chosen to ensure that there are two pairs  $(a, b)$  and  $(c, d)$  in the chosen set such that

$$a \equiv c \pmod{3} \text{ and } b \equiv d \pmod{5}$$

- (A) 4                      (B) 6                      (C) 16                      (D) 24

Q.45 Consider three decision problems  $P_1$ ,  $P_2$  and  $P_3$ . It is known that  $P_1$  is decidable and  $P_2$  is undecidable. Which one of the following is TRUE?

- (A)  $P_3$  is decidable if  $P_1$  is reducible to  $P_3$   
(B)  $P_3$  is undecidable if  $P_3$  is reducible to  $P_2$   
(C)  $P_3$  is undecidable if  $P_2$  is reducible to  $P_3$   
(D)  $P_3$  is decidable if  $P_3$  is reducible to  $P_2$ 's complement

Q.46 Consider the set  $H$  of all  $3 \times 3$  matrices of the type

$$\begin{bmatrix} a & f & e \\ 0 & b & d \\ 0 & 0 & c \end{bmatrix}$$

where  $a, b, c, d, e$  and  $f$  are real numbers and  $abc \neq 0$ . Under the matrix multiplication operation, the set  $H$  is:

- (A) a group                      (B) a monoid but not a group  
(C) a semigroup but not a monoid                      (D) neither a group nor a semigroup



- Q.21** What is the swap space in the disk used for?  
 (A) Saving temporary html pages (B) Saving process data  
 (C) Storing the super-block (D) Storing devices drivers
- Q.22** Increasing the RAM of a computer typically improves performance because:  
 (A) Virtual memory increases (B) Larger RAMs are faster  
 (C) Fewer page faults occur (D) Fewer segmentation faults occur
- Q.23** Packets of the same session may be routed through different paths in:  
 (A) TCP, but not UDP (B) TCP and UDP  
 (C) UDP, but not TCP (D) Neither TCP, nor UDP
- Q.24** The *address resolution protocol* (ARP) is used for:  
 (A) Finding the IP address from the DNS  
 (B) Finding IP address of the default gateway  
 (C) Finding the IP address that corresponds to a MAC address  
 (D) Finding the MAC address that corresponds to an IP address
- Q.25** The maximum window size for data transmission using the *selective reject protocol* with  $n$ -bit frame sequence numbers is:  
 (A)  $2^n$  (B)  $2^{n-1}$  (C)  $2^n - 1$  (D)  $2^{n-2}$
- Q.26** In a network of LANs connected by bridges, packets are sent from one LAN to another through intermediate bridges. Since more than one path may exist between two LANs, packets may have to be routed through multiple bridges. Why is the *spanning tree algorithm* used for bridge-routing?  
 (A) For shortest path routing between LANs  
 (B) For avoiding loops in the routing paths  
 (C) For fault tolerance  
 (D) For minimizing collisions
- Q.27** An organization has a class B network and wishes to form subnets for 64 departments. The subnet mask would be:  
 (A) 255.255.0.0 (B) 255.255.64.0 (C) 255.255.128.0 (D) 255.255.252.0
- Q.28** Which one of the following is a key factor for preferring B<sup>+</sup>-trees to binary search trees for indexing database relations?  
 (A) Database relations have a large number of records  
 (B) Database relations are sorted on the primary key  
 (C) B<sup>+</sup>-trees require less memory than binary search trees  
 (D) Data transfer from disks is in blocks
- Q.29** Which one of the following statements about normal forms is FALSE?  
 (A) BCNF is stricter than 3NF  
 (B) Lossless, dependency-preserving decomposition into 3NF is always possible  
 (C) Lossless, dependency-preserving decomposition into BCNF is always possible  
 (D) Any relation with two attributes is in BCNF

- 70.** The following statements  

```
for(i = 3; i < 15; i += 3)
{ printf("%d ", i);
 ++i;
}
```

 will result in the printing of  
 (a) 3 6 9 12 (b) 3 6 9 12 15 (c) 3 7 11 (d) 3 7 11 15
- 71.** If  $a = 9$ ,  $b = 5$  and  $c = 3$ , then the expression  $(a - a/b * b\%c) > a\%b\%c$  evaluates to  
 (a) true (b) false (c) invalid (d) 0
- 72.** In a `for` loop, if the condition is missing, then,  
 (a) it is assumed to be present and taken to be false  
 (b) it is assumed to be present and taken to be true  
 (c) it results in a syntax error  
 (d) execution will be terminated abruptly
- 73.** In a `for` loop, if the condition is missing, then infinite looping can be avoided by a  
 (a) `continue` statement (b) `goto` statement  
 (c) `return` statement (d) `break` statement
- 74.** Choose the correct statement.  
 (a) 0 represents a false condition.  
 (b) Non-zero value represents a false condition.  
 (c) 1 represents a false condition.  
 (d) Anything that is not 1, represents a false condition.
- 75.** Which of the following comments about `for` loop are correct?  
 (a) Index value is retained outside the loop.  
 (b) Index value can be changed from within the loop.  
 (c) `goto` can be used to jump, out of loop.  
 (d) Body of the loop can be empty.
- 76.** Which of the following comments about `for` loop are correct?  
 (a) Using `break` is equivalent to using a `goto` that jumps to the statement immediately following the loop.  
 (b) `Continue` is used to by-pass the remainder of the current pass of the loop.  
 (c) If comma operator is used, then the value returned is the value of the right operand.  
 (d) It can always be replaced by a `while` loop.
- 77.** Choose the correct answers.  
 (a) `for` loops can be nested  
 (b) Nested `for` loop can't use the same index variable  
 (c) Nested `for` loop can't overlap  
 (d) None of the above

78. Consider the following program fragment

```
if (a > b)
if (b > c)
s1;
else s2;
```

s2 will be executed if

- (a)  $a \leq b$       (b)  $b > c$       (c)  $b \leq c$  and  $a \leq b$       (d)  $a > b$  and  $b \leq c$

79. If switch feature is used, then

- (a) default case must be present  
 (b) default case, if used, should be the last case  
 (c) default case, if used, can be placed anywhere  
 (d) none of the above

80. The switch feature

- (a) can always be replaced by a nested if-then-else clause  
 (b) enhances logical clarity  
 (c) can't always be replaced by a nested if-then-else clause  
 (d) none of the above

81. break statement can be simulated by using

- (a) goto      (b) return  
 (c) exit      (d) any of the above features

\*82. The following program fragment

```
if (2 < 1)
;
else
x = (2 < 0)? printf("one") : printf("four");
printf ("%d", x);
```

- (a) prints nothing      (b) results in a syntax error  
 (c) prints four0      (d) none of the above

\*83. Consider the following program fragment

```
if (a > b)
printf("a > b");
else
printf("else part");
printf("a <= b");
```

a  $\leq$  b will be printed if

- (a)  $a > b$       (b)  $a < b$       (c)  $a = b$       (d) none of the above

(B) An array of 100 numbers

(C) An array of 500 numbers

(D) A dynamically allocated array of 550 numbers

Q.6 An undirected graph  $G$  has  $n$  nodes. Its adjacency matrix is given by an  $n \times n$  square matrix whose (i) diagonal elements are 0's, and (ii) non-diagonal elements are 1's. Which one of the following is TRUE?

(A) Graph  $G$  has no minimum spanning tree (MST)

(B) Graph  $G$  has a unique MST of cost  $n - 1$

(C) Graph  $G$  has multiple distinct MSTs, each of cost  $n - 1$

(D) Graph  $G$  has multiple spanning trees of different costs

Q.7 The time complexity of computing the transitive closure of a binary relation on a set of  $n$  elements is known to be:

(A)  $O(n)$

(B)  $O(n \log n)$

(C)  $O(n^{3/2})$

(D)  $O(n^3)$

Q.8 Let A, B and C be non-empty sets and let

$$X = (A - B) - C \text{ and } Y = (A - C) - (B - C)$$

Which one of the following is TRUE?

(A)  $X = Y$

(B)  $X \subset Y$

(C)  $Y \subset X$

(D) none of these

Q.9 The following is the Hasse diagram of the poset  $\{\{a, b, c, d, e\}, \leq\}$

The poset is:

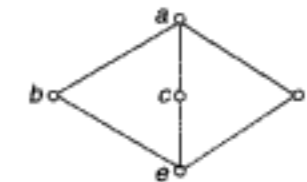

(A) not a lattice

(B) a lattice but not a distributive lattice

(C) a distributive lattice but not a Boolean algebra

(D) a Boolean algebra

Q.10 Let  $G$  be a simple connected planar graph with 13 vertices and 19 edges. Then, the number of faces in the planar embedding of the graph is:

(A) 6

(B) 8

(C) 9

(D) 13

Q.11 Let  $G$  be a simple graph with 20 vertices and 100 edges. The size of the minimum vertex cover of  $G$  is 8. Then, the size of the maximum independent set of  $G$  is:

(A) 12

(B) 8

(C) Less than 8

(D) More than 12

Q.12 Let  $f(x)$  be the continuous probability density function of a random variable  $X$ . The probability that  $a < X \leq b$ , is:

(A)  $f(b - a)$

(B)  $f(b) - f(a)$

(C)  $\int_a^b f(x) dx$

(D)  $\int_a^b xf(x) dx$

5. Write your registration number, name and name of the Centre at the specified locations on the right half of the ORS.
6. Using HB pencil, darken the appropriate bubble under each digit of your registration number and the letters corresponding to your paper code.
7. Calculator is allowed in the examination hall.
8. Charts, graph sheets or tables are not allowed.
9. Use the blank pages given at the end of the question paper for rough work.
10. This question paper contains 24 printed pages including pages for rough work. Please check all pages and report, if there is any discrepancy.

**Q.1-Q.30 carry one mark each**

**Q.1** What does the following C-statement declare?

```
int (* f)(int *);
```

- (A) A function that takes an integer pointer as argument and returns an integer
- (B) A function that takes an integer as argument and returns an integer pointer
- (C) A pointer to a function that takes an integer pointer as argument and returns an integer
- (D) A function that takes an integer pointer as argument and returns a function pointer

**Q.2** An Abstract Data Type (ADT) is:

- (A) same as an abstract class
- (B) a data type that cannot be instantiated
- (C) a data type for which only the operations defined on it can be used, but none else
- (D) all of the above

**Q.3** A common property of logic programming languages and functional languages is:

- (A) both are procedural languages
- (B) both are based on  $\lambda$ -calculus
- (C) both are declarative
- (D) both use Horn clauses

**Q.4** Which one of the following are essential features of an object-oriented programming language?

- (i) Abstraction and encapsulation
- (ii) Strictly-typedness
- (iii) Type-safe property coupled with sub-type rule
- (iv) Polymorphism in the presence of inheritance

- (A) (i) and (ii) only
- (B) (i) and (iv) only
- (C) (i), (ii) and (iv) only
- (D) (i), (iii) and (iv) only

**Q.5** A program P reads in 500 integers in the range [0, 100] representing the scores of 500 students. It then prints the frequency of each score above 50. What would be the best way for P to store the frequencies?

- (A) An array of 50 numbers

**84.** Consider the following flow chart.

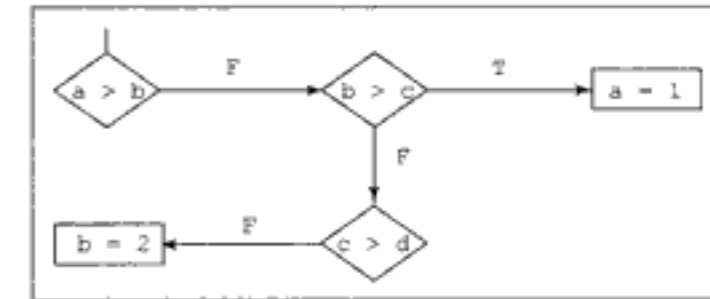

**Fig. 1.1**

Which of the following, correctly implements the above flow chart?

- |                                                                                                                                                                                        |                                                                                                                                                                                                                |
|----------------------------------------------------------------------------------------------------------------------------------------------------------------------------------------|----------------------------------------------------------------------------------------------------------------------------------------------------------------------------------------------------------------|
| <p>(a) <code>if (a &gt; b)</code><br/> <code>if (b &gt; c)</code><br/> <code>a = 1;</code><br/> <code>else if (c &gt; d)</code><br/> <code>b = 2;</code></p>                           | <p>(b) <code>if (a &lt;= b)</code><br/> <code>if (b &gt; c)</code><br/> <code>a = 1;</code><br/> <code>else if (c &lt;= d)</code><br/> <code>b = 2;</code></p>                                                 |
| <p>(c) <code>if (a &gt; b)</code><br/> <code>;</code><br/> <code>else if (b &gt; c)</code><br/> <code>a = 1;</code><br/> <code>else if (c &lt;= d)</code><br/> <code>b = 2;</code></p> | <p>(d) <code>if (a &gt; b)</code><br/> <code>;</code><br/> <code>else if (b &gt; c)</code><br/> <code>a = 1;</code><br/> <code>else if (c &gt; d)</code><br/> <code>;</code><br/> <code>else b = 2;</code></p> |

**\*85.** The body of the following for loop

```
for(putchar('a'); putchar(0); putchar('c'))
 putchar('b');
```

will be executed

- (a) 0 times
- (b) 1 time
- (c) infinitely many times
- (d) will not be executed because of syntax error

**86.** The following statement

```
if (a > b)
if (c > b)
printf("one");
else
if (c == a) printf("two");
else printf("three");
else printf("four");
```

- (a) results in a syntax error
- (b) prints four in  $c \leq b$
- (c) prints two if  $c \leq b$
- (d) prints four in  $a \leq b$



87. The above statement can never print  
 (a) one (b) two (c) three (d) four
88. The following program fragment  

```
int x = 4, y = x, i;
for (i = 1; i < 4; ++i)
 x += x;
```

 outputs an integer that is same as  
 (a)  $8 * y$  (b)  $y * (1 + 2 + 3 + 4)$   
 (c)  $y * 4$  (d)  $y * y$
89. Using goto inside for loop is equivalent to using  
 (a) continue (b) break (c) return (d) none of the above
- \*90. Choose the correct statements.  
 (a) All the elements of the array should be of the same data type and storage class.  
 (b) The number of subscripts determines the dimension of the array.  
 (c) The array elements need not be of the same storage class.  
 (d) In an array definition, the subscript can be any expression yielding a non-zero integer value.
91. Consider the declaration  

```
static char hello[]="hello";
```

 The output of `printf("%s\n", hello);`  
 will be the same as that of  
 (a) `puts("hello");` (b) `puts(hello);`  
 (c) `printf("%s\n", "hello");` (d) `puts("hello\n");`
- \*92. If storage class is missing in the array definition, by default it will be taken to be  
 (a) automatic  
 (b) external  
 (c) static  
 (d) either automatic or external depending on the place of occurrence.
93. The following program fragment  

```
int x[5][5], i, j;
for(i = 0; i < 5; ++i)
 for(j = 0; j < 5; j++)
 x[i][j] = x[j][i];
```

 (a) transposes the given matrix x (b) makes the given matrix x, symmetric  
 (c) doesn't alter the matrix x (d) none of the above
94. Which of the following features of C is meant to provide reliable access to special memory locations?  
 (a) `static_const` (b) `pragma` (c) `volatile` (d) `immutable`

## Appendix

# Computer Science Question Paper for GATE 2005

## CS: Computer Science and Engineering

Duration: Three Hours

Maximum Marks: 150

Read the following instructions carefully.

- This question paper contains all objective questions. Q.1 to Q.30 carry **one** mark each and Q.31 to Q.80 carry **two** marks each. Q.81 to Q.85 each contains part "a" and "b". In these questions, parts "a" as well as "b" carry **two** marks each.
- Answer all the questions.
- Questions must be answered on special machine gradable **Objective Response Sheet (ORS)** by darkening the appropriate bubble (marked A, B, C, D) against the question number on the left hand side of the **ORS**, using **HB** pencil. **Each question has only one correct answer.** In case you wish to change an answer, erase the old answer completely using a good soft eraser.
- There will be **NEGATIVE** marking. In Q.1 to Q.30, **0.25** mark will be deducted for each wrong answer and in Q.31 to Q.80, **0.5** mark will be deducted for each wrong answer. In Q.81 to Q.85, for the part "a", **0.5** mark will be deducted for a wrong answer. Marks for correct answers to part "b" of Q.81 to Q.85 will be given only if the answer to the corresponding part "a" is correct. However, there is no negative marking for part "b" of Q.81 to Q.85. More than one answer bubbled against a question will be deemed as an incorrect response.

SUBSTR('123456', -2) extracts the substring starting at the second location from the last (because of the - sign) till the end.

SUBSTR('123456', 5, 2) extracts the substring of length 2 (the third (optional) argument specifies the length) starting at location 5 (the count starts from 1).

SUBSTR('123456', -2) extracts the substring of length 2 starting at the second location from the last (because of the - sign)

96. LPAD('abcd',10,'wert') means, in a field of length 10, pad the string 'abcd' on the left side with the string 'wert'
97. ROUND(45.926,-2) rounds 2 decimal places to the left of the decimal point (left because of the - sign). This essentially means round to the nearest hundred. So, 45 will be rounded to 0
99. NVL(NVL(NULL, NVL(NULL, 3)), 4) is equivalent to NVL(NVL(NULL, 3), 4), which is equivalent to NVL(3, 4)
101. SELECT SUBSTR('myname@abcd.com', INSTR('myname@abcd.com', '@', 1) + 1) FROM DUAL; prints whatever that comes after the @ character which is the domain name.
103. Whenever a NOT IN list includes NULL, this is what happens.
106. ROWNUM is a pseudo-column that is used to label the rows of the result set. This query cannot return any row because if it returns a row (or more than one row) the first record must have a ROWNUM of greater than 5. But the first row will have the ROWNUM 1.
107. NULL in (NULL) is logically equivalent to NULL = NULL
108. TRUNC(45.926,-2) truncates 2 decimal places to the left of the decimal point (left because of the - sign). The 45 will be made 0
109. IS NULL is the right way to check if something is NULL.
130. You cannot specify the size
132. WNDIS stands for Writes No Database State.  
WNPS stands for Writes No Package State.  
RNDIS stands for Reads No Database State.  
RNPS stands for Reads No Package State.
139. They are sparse, meaning a row exists only when it is assigned a value. They are unconstrained, meaning rows can be added dynamically.
159. It puts the input focus back in the data item that caused the validation failure.
175. Only if the "Display Hint Automatically" property is set, it will be displayed automatically.
186. For the same reason a Boolean variable is initialized to FALSE rather than TRUE at declaration.
193. There are certain items that cannot receive the input focus. Such items cannot have a Hint associated to them. The Tooltip displays the message when the cursor is over the item.
198. The "Check Box Mapping of Other Values" property determines if the Check box is Checked or Unchecked.
199. Combo Box lets the user search the list by typing the first few characters of the search value. Note that LOV is the best choice to implement a list that is long.
201. It can also be used to count, compute standard deviation and find the minimum.
234. Because the data type of a bind variable is CHAR by default.

95. Consider the array definition

```
int num[10] = {3, 3, 3};
```

Pick the correct answers.

- (a) num[9] is the last element of the array num  
(b) The value of num[8] is 3  
(c) The value of num[3] is 3  
(d) None of the above.

96. Consider the following type definition.

```
typedef char x[10];
x myArray[5];
```

What will sizeof(myArray) be? (Assume one character occupies 1 byte)

- (a) 15 bytes                      (b) 10 bytes                      (c) 50 bytes                      (d) 30 bytes

97. While passing an array as an actual argument, the function call must have the array name

- (a) with empty brackets                      (b) with its size  
(c) alone                      (d) none of the above

- \*98. The following program

```
main()
{
 static int a[] = {7,8,9};
 printf("%d", 2[a] + a[2]);
}
```

- (a) results in bus error                      (b) results in segmentation violation error  
(c) will not compile successfully                      (d) none of the above

99. The parameter passing mechanism for an array is

- (a) call by value                      (b) call by value-result  
(c) call by reference                      (d) none of these

100. Consider the statement

```
int val[2][4] = {1, 2, 3, 4, 5, 6, 7, 8};
```

4 will be the value of

- (a) val[1][4]                      (b) val[0][4]  
(c) val[1][1]                      (d) none of the above

101. The maximum number of dimension an array can have in C is

- (a) 3                      (b) 4                      (c) 5                      (d) compiler dependent

102. The following program fragment

```
int m, n, b = m = n = 8;
char wer[80];
sprintf(wer, "%d%d%d", m, n, b);
puts(wer);
```

- (a) prints the string 8 8 8                      (b) prints the null string  
(c) prints the string 888                      (d) none of the above

103. Under which of the following conditions, the size of an one-dimensional array need not be specified?
- when initialization is a part of definition
  - when it is a declaration
  - when it is a formal parameter
  - when it is an actual argument
104. If a two dimensional array is used as a formal parameter, then
- both the subscripts may be left empty
  - the first (row) subscript may be left empty
  - the first subscript must be left empty
  - both the subscripts must be left empty
105. The following program
- ```
main()
{
    static char a[3][4] = {"abcd", "mnop", "fghi"};
    putchar(**a);
}
```
- will not compile successfully
 - results in run-time error
 - prints garbage
 - none of the above
106. C does no automatic array bound checking. This is
- true
 - false
 - C's asset
 - C's shortcoming

Answer the next three questions based on the program fragment given below

```
int hh = 16;
static char wer[] = "NO SUBSTITUTE FOR HARD WORK";
```

107. `printf("%10.5s", wer);`
outputs
- NO SU
 - NO SUBSTIT
 - NO SU
 - UTE F
108. `printf("%-10.5s", wer);`
outputs
- NO SU
 - NO SUBSTIT
 - NO SU
 - UTE F

46. It prints all possible x, y where x can be one of the 10 values – 2001, 2002, ..., 2010 and y can be one of the 10 values – 2001, 2002, ..., 2010, giving us $10 \times 10 = 100$ rows.
49. Because CustNum 1008 ordered neither a pen nor a pencil.
50. The 8 rows are 1001, 1002, 1006, 1009, 1001, 1002, 1007, 1009.
51. This query lists out all CustNum who ordered pen and pencil.
52. This query lists out 1003, 1004, 1005, 1008, 1009, and 1010. You might have missed 1009 thinking the order includes pen/pencil. If you analyze the query you will find that 1009 is included because order 2009 includes table.
53. The CustNum 1009 will be displayed.
54. The CustNum that are displayed are 1003 and 1005.
55. Every CustNum ordered at least one of table, chair, pen or pencil. So, the first query returns all the 10 CustNum. For similar reasons, the second query also returns all the 10 CustNum.
57. If it is 20, this query counts and displays all CusNum who placed order for an item that is worth more than Rs.20. The possible items are table and chair. There are exactly 6 CustNum who ordered for a table or chair.
58. This query finds and displays the CustNum who placed the most recent order.
59. BETWEEN includes the end values.
60. `SELECT SUBSTR(TO_CHAR(SYSDATE), 8) FROM DUAL,` displays the string 05. The given query finds and displays those CustNum who placed order in the year 05.
62. NULL is not equal to NULL
63. Option (a) prints 0.
Option (b) prints 2.
Option (a) prints -2.
67. You can verify by executing the PL/SQL code
- ```
IF LENGTH('') IS NULL THEN
 DBMS_OUTPUT.PUT_LINE('Hi');
ELSE
 DBMS_OUTPUT.PUT_LINE('Bye');
END IF;
```
- This will print Hi
71. ALL is optional. Its presence or absence doesn't change the output. Unlike DISTINCT, it allows duplicates in the output.
72. `NVL(NULL, 3)` returns 3. So, `NVL(NVL(NULL, 3), 4)` is equivalent to `NVL(3, 4)`
73. This query counts the number of employees who get more than the maximum salary.
74. NULL is neither equal to NULL nor not equal to NULL.
77. Simple Join is yet another name for Equijoin.
79. It prints the two records
- | From    | To        |
|---------|-----------|
| Chennai | New Delhi |
| Chennai | Agra      |



21. a,b,c,d  
22. d  
23. b  
24. b  
25. b  
26. d  
27. a,b,c  
28. b  
29. a  
30. b,c  
31. d  
32. b  
33. b  
34. d  
35. c  
36. a  
37. a  
38. d  
39. c  
40. d  
41. d  
42. a  
43. a  
44. d  
45. a  
46. c  
47. a  
48. c  
49. c  
50. b  
51. c  
52. c  
53. b  
54. c  
55. a  
56. b,c,d  
57. c  
58. a  
59. c  
60. d  
61. a  
62. d  
63. d  
64. a,b  
65. a  
66. a,b  
67. c  
68. b  
69. b  
70. a  
71. c  
72. a  
73. d  
74. d  
75. d  
76. d  
77. c  
78. c  
79. c  
80. c  
81. c  
82. d  
83. b  
84. d  
85. d  
86. b  
87. b  
88. c  
89. d  
90. a  
91. b,d  
92. a,b  
93. a,b,c,d  
94. d  
95. a,b,c,d  
96. a  
97. d  
98. a,b,c,d  
99. a  
100. c  
101. a  
102. a  
103. d  
104. a  
105. b  
106. d  
107. d  
108. d  
109. a  
110. d  
111. b  
112. d  
113. c  
114. b,d  
115. d  
116. d  
117. a,c  
118. d  
119. c  
120. a  
121. b,c,d  
122. b  
123. d  
124. c  
125. d  
126. a,c  
127. b  
128. c  
129. c  
130. a,d  
131. a  
132. d  
133. c  
134. a  
135. c  
136. b  
137. a,c,d  
138. c  
139. a,b,c  
140. a  
141. a,b,c,d  
142. a,b  
143. a,d  
144. a,b,c,d  
145. a,b,c  
146. a,b,c  
147. d  
148. a  
149. b,d  
150. c  
151. a,c  
152. d  
153. d  
154. b  
155. d  
156. a  
157. d  
158. d  
159. d  
160. a,b,c  
161. a,b  
162. d  
163. b  
164. a  
165. c  
166. b  
167. a  
168. d  
169. b,c  
170. c  
171. d  
172. a,b  
173. b  
174. a  
175. a,c  
176. d  
177. d  
178. b  
179. d  
180. d  
181. c  
182. b  
183. a,c  
184. a,b,c  
185. a  
186. b  
187. a  
188. c  
189. a  
190. a,b,c  
191. b  
192. c  
193. a,b,c  
194. c  
195. a,d  
196. d  
197. b  
198. d  
199. a  
200. c  
201. a,b,c,d  
202. d  
203. d  
204. a  
205. a  
206. a,b  
207. a,b,c  
208. b  
209. c  
210. c  
211. d  
212. a  
213. c  
214. d  
215. b  
216. c  
217. b  
218. d  
219. a,b,c  
220. a  
221. c  
222. a  
223. a  
224. a,b  
225. c  
226. c  
227. a,b,c  
228. a  
229. a  
230. d  
231. b,c  
232. a  
233. a,d  
234. c  
235. d  
236. d  
237. a,d  
238. c  
239. c  
240. d

109. `printf("%-10.*s", hh, wer);`  
outputs  
(a) NO SU (b) NO SUBSTITUTE FO  
(c) NO SU (d) error message
110. If `n` has the value 3, then the statement `a[++n] = n++;`  
(a) assigns 3 to `a[5]` (b) assigns 4 to `a[5]`  
(c) assigns 4 to `a[4]` (d) what is assigned is compiler-dependent
111. Choose the statement that best defines an array.  
(a) It is a collection of items that share a common name.  
(b) It is a collection of items that share a common name and occupy consecutive memory locations.  
(c) It is a collection of items of the same type and storage class that share a common name and occupy consecutive memory locations.  
(d) None of the above.
- \*112. Choose the correct statements.  
(a) Strictly speaking C supports 1-dimensional arrays only.  
(b) An array element may be an array by itself.  
(c) Array elements need not occupy contiguous memory locations.  
(d) None of the above.
- \*113. The order in which actual arguments are evaluated in a function call  
(a) is from the left (b) is from the right  
(c) is compiler-dependent (d) none of the above
114. If a global variable is of storage class static, then  
(a) the static declaration is unnecessary if the entire source code is in a single file  
(b) the variable is recognized only in the file in which it is defined  
(c) it results in a syntax error  
(d) none of the above
- \*115. Which of the following statements are correct?  
(a) It is possible for a function to access a variable that is local to another function.  
(b) Two local variables may have the same name.  
(c) The scope of a local variable should be a function.  
(d) The scope of a local variable may be a single statement.
- \*116. The default parameter passing mechanism is  
(a) call by value (b) call by reference  
(c) call by value result (d) none of the above
117. Choose the correct statements.  
(a) During external variable definition, storage is set aside by the compiler.  
(b) During external variable declaration, no storage is set aside by the compiler.  
(c) The use of external variables may make debugging difficult.  
(d) None of the above.



118. The storage class `static` can be used to
- restrict the scope of an external identifier
  - preserve the exit value of variables
  - provide privacy to a set of functions
  - none of the above

\*119. The following program

```
main()
{printf("tim");
 main();}
```

- is illegal
- keeps on printing `tim`
- prints `tim` once
- none of the above

\*120. Consider the following program.

```
main()
{ putchar('M');
 first();
 putchar('m'); }
first()
{ _____ }
second()
{ putchar('d'); }
```

If Madam is the required output, then the body of `first()` must be

- empty
- `second(); putchar('a');`
- `putchar('a'); second(); printf("%c", 'a');`
- none of the above.

121. Use of functions

- helps to avoid repeating a set of statements many times
- enhances the logical clarity of the program
- helps to avoid repeated programming across programs
- makes the debugging task easier

122. Which of the following comments about wide characters is/are true?

- It is the binary representation of a character in the extended binary set.
- It is of integer type `wchar_t`.
- End of file is represented by `WEOF`.
- None of the above.

123. Pick the correct statements.

- The body of a function should have only one `return` statement.
- The body of a function may have many `return` statements.
- A function can `return` only one value to the calling environment.
- If `return` statement is omitted, then the function does its job but returns no value to the calling environment.

236. The address of a customer usually spans 4 lines – Address Line 1, Address Line 2, Address Line 3, and Address Line 4. Some customers don't have Address Line 2. The invoice when printed will show an empty second line for such customers. How do you prevent this from happening?

- This cannot be prevented
- By using anchors
- By using format triggers
- By using anchors and format triggers

237. Let Field1 and Field2 be two fields that are connected by an anchor as follows.



Field1 is the Parent Object and Field2 is the Child Object. The values of the Child Edge Type and Child Edge Percent can be

- Top, 0 respectively
- Bottom, 100 respectively
- Left, 100 respectively
- Left, 0 respectively

238. If the After Parameter trigger fails

- nothing happens
- the Report gets terminated abruptly
- you will be put in the parameter form again
- none of the above

239. Consider the query `SELECT * FROM EMP WHERE deptno = :abc;`

Let there be a Validation Trigger for the variable `abc` that is coded as follows.

```
IF (:abc IN (10,20,40)) THEN
 return(TRUE);
ELSE
 return(FALSE);
END IF
```

During runtime, if the user enters a value other than 10, 20, or 40,

- the value will be discarded
- the user will be asked to enter another value
- an exception will be raised
- the value will be defaulted to 10

240. An object in a Repeating Frame must

- belong to its associated group or must be from a parent group
- belong to its associated group or must be defined at Report level
- be from a parent group or must be defined at Report level
- belong to its associated group or must be from a parent group or must be defined at Report level

### Answers

- |             |          |       |        |             |
|-------------|----------|-------|--------|-------------|
| 1. a,b,c    | 2. c     | 3. d  | 4. b,d | 5. a,c      |
| 6. d        | 7. a,b,c | 8. d  | 9. d   | 10. c       |
| 11. a,b,c,d | 12. a,b  | 13. a | 14. d  | 15. a,b,c,d |
| 16. a       | 17. d    | 18. c | 19. c  | 20. b       |

- (c) This feature cannot be implemented through Check Boxes or Radio Buttons.  
 (d) None of the above is correct.
- \*198. If a trigger code assigns a value to a Check Box that neither matches the "Value When Checked" nor the "Value When Unchecked", the Check Box will be  
 (a) Checked (b) Unchecked (c) unpredictable (d) none of these
- \*199. Which of the following list items is a good choice to implement lists that are long?  
 (a) Combo Box (b) Poplist (c) Tlist (d) Llist
200. Which of the following can be used to create variables that can be accessed by any Form executing in the current Form session?  
 (a) System variables (b) Parameter variables  
 (c) Global variables (d) None of these
- \*201. A calculated item in a Form can be used to compute  
 (a) sum (b) average (c) maximum (d) variance
202. Which of the following button does not appear when an LOV is listed?  
 (a) Find (b) OK (c) Cancel (d) None of these
203. Which of the following is not a type of canvas?  
 (a) Content (b) Vertical toolbar (c) Tab (d) None of these
204. In a master-detail Form, RELATION is  
 (a) an object belonging to the master data block  
 (b) an object belonging to the detail data block  
 (c) an object that belongs neither to the master data block nor the detail block.  
 (d) not an object
205. Which of the following is the plug-in that facilitates interaction between the FORMS server and the web browser?  
 (a) JInitiator (b) JApplet (c) IDE (d) WebFor
206. A canvas is displayed when  
 (a) an item in the canvas receives the input focus  
 (b) the window that is associated with the canvas is opened  
 (c) the data block that is associated with the canvas is opened  
 (d) all of these
207. Which of the following built-ins can be used to launch a new Form from within a Form?  
 (a) Call\_Form (b) New\_Form (c) Open\_Form (d) None of these
208. Setting the value of the system variable MESSAGE\_LEVEL to 0  
 (a) results in the suppressing of all the messages irrespective of their severity  
 (b) does not suppress the display of any message  
 (c) will result in syntax error  
 (d) is desirable when the Form is moved from development to production
209. Which of the following list items is the worst choice to implement lists that are long?  
 (a) Combo Box (b) Poplist (c) Tlist (d) None of these

124. max is a function that returns the larger of the two integers, given as arguments. Which of the following statements finds the largest of three given numbers?  
 (a) max(max(a, b), max(a, c))  
 (b) max(a, max(a, c))  
 (c) max(max(a, b), max(b, c))  
 (d) max(b, max(a, c))
125. Forward declaration is absolutely necessary  
 (a) if a function returns a non-integer quantity  
 (b) if the function call precedes its definition  
 (c) if the function call precedes its definition and the function returns a non integer quantity  
 (d) none of the above
126. void can be used  
 (a) as a data-type of a function that returns nothing to its calling environment  
 (b) inside the brackets of a function that does not need any argument  
 (c) in an expression  
 (d) in a printf statement
127. Any C program  
 (a) must contain at least one function (b) need not contain any function  
 (c) needs input data (d) none of the above
- \*128. The following program  

```
main()
{ int a = 4;
 change(a);
 printf("%d", a);
}
change(a)
int a;
{ printf("%d", ++a);}
```

 outputs  
 (a) 55 (b) 45 (c) 54 (d) 44
129. Choose the best answer.  
 Storage class defines  
 (a) the datatype (b) the scope  
 (c) the scope and permanence (d) the scope, permanence and datatype
130. Which of the following is true of external variables?  
 (a) They provide a way for two way communication between functions.  
 (b) Their scope extends from the point of definition through the remainder of the program.  
 (c) If they are not initialized, they will have garbage value.  
 (d) None of the above.

\*131. The following program

```
main()
{
 int i = 2;
 { int i = 4, j = 5;
 printf("%d%d", i, j);
 }
 printf("%d%d", i, j);
}
```

- (a) will not compile successfully  
(b) prints 4525  
(c) prints 2525  
(d) none of the above

\*132. The following program

```
main()
{
 inc(); inc(); inc();
}
inc()
{
 static int x;
 printf("%d", ++x);
}
```

- (a) prints 012  
(b) prints 123  
(c) prints 3 consecutive, but unpredictable numbers  
(d) prints 111

133. printf("ab", "cd", "ef");

- prints  
(a) ab  
(b) abcdef  
(c) abcdef, followed by garbage  
(d) none of the above

134. The expression  $4 + 6 / 3 * 2 - 2 + 7 \% 3$  evaluates to

- (a) 3  
(b) 4  
(c) 6  
(d) 7

135. Consider the following program segment.

```
i = 6720; j = 4;
while ((i%j)==0)
{ i = i / j;
 j = j + 1;
}
```

On termination j will have the value

- (a) 4  
(b) 8  
(c) 9  
(d) 6720

178. Suppose that a WHEN-VALIDATE-ITEM trigger and a POST-TEXT-ITEM trigger are defined for a particular text item. Which of them will be fired first?

- (a) POST-TEXT-ITEM  
(b) WHEN-VALIDATE-ITEM  
(c) Unpredictable  
(d) Both of them will be fired simultaneously

179. To debug a PL/SQL code that is within a Form, appropriate messages can be displayed at different points in the execution flow using the built-in

- (a) print  
(b) display  
(c) show  
(d) message

180. In a Form, trigger cannot be defined at

- (a) Form level  
(b) data block level  
(c) data item level  
(d) none of these

181. Which of the following properties of a RELATION determines how to handle records in the detail data block if the associated record in the master data block is deleted?

- (a) Deferred  
(b) Automatic Query  
(c) Delete Record Behavior  
(d) None of these

182. Let BN be the block name and DIN be the data item name. To reference DIN the syntax to be used is

- (a) BN.DIN  
(b) BN.DIN  
(c) DIN  
(d) 'BN.DIN'

183. Choose the correct statements.

- (a) An unrestricted built-in can be called by any trigger code.  
(b) A restricted built-in can be called by any trigger code.  
(c) Restricted built-ins have something to do with the Form navigation.  
(d) Unrestricted built-ins have something to do with the Form navigation

184. The value of the "Delete Record Behavior" property of a RELATION in a master-detail Form can be

- (a) cascading  
(b) isolated  
(c) non-isolated  
(d) none of these

185. To reference a parameter ParamA that is defined in a Form, the syntax to be used is

- (a) :parameter.ParamA  
(b) parameter.ParamA  
(c) parameter:ParamA  
(d) none of these

\*186. Logically speaking, in general, it is a good idea to set the value of the "Check Box Mapping of Other Values" property to the value of the property

- (a) "Value When Checked"  
(b) "Value When Unchecked"  
(c) NULL  
(d) none of these

187. You want to prevent a user from navigating past the last record in a data block. The natural choice to enforce this, is through a

- (a) block level trigger  
(b) form level trigger  
(c) item level trigger  
(d) application level trigger

188. You want to prevent a user from navigating past the last record in a data block. The code used to implement this feature uses

- (a) parameter variable  
(b) global variable  
(c) system variable  
(d) none of these

167. To programmatically set a RELATION property in a master-detail Form, use the
- SET\_RELATION\_PROPERTY built-in
  - SET\_RELATION built-in
  - DEFINE\_RELATION\_PROPERTY built-in
  - DEF\_RELATION\_PROPERTY built-in
168. Which of the following statements about windows, canvases, and data items is correct?
- A window is placed on a data item, which is displayed in a canvas.
  - A canvas is placed on a data item, which is displayed in a window.
  - A data item is placed on a window, which is displayed in a canvas.
  - A data item is placed on a canvas, which is displayed in a window.
169. Choose the correct statements.
- A data block is associated with a canvas.
  - The size of the canvas can be larger than the size of the window.
  - The size of the canvas can be smaller than the size of the window.
  - All of the above are correct.
170. The items of a data block can be grouped within a
- record group
  - program unit
  - frame
  - data store
171. A set of properties can be collectively assigned to an object by using
- record group
  - object group
  - array
  - property class
172. In a master-detail Form, the records in the detail data block are not retrieved immediately when the
- deferred property is set to Yes and the Automatic Query property is set to No.
  - deferred property is set to Yes and the Automatic Query property is set to Yes.
  - deferred property is set to No and the Automatic Query property is set to No.
  - deferred property is set to No and the Automatic Query property is set to Yes.
173. You cannot navigate to a data item if it is a
- button
  - display item
  - text item
  - check box
174. Records retrieved by a data block can be filtered by appropriately setting the value of the
- where clause property
  - number of records returned property
  - select clause property
  - all of these
- \*175. Which of the following comments about HINT are correct?
- It is an item property.
  - It is automatically displayed when the associated item receives the input focus.
  - It may not be automatically displayed when the associated item receives the input focus.
  - None of the above are correct.
176. Which of the following is a collection of Form components?
- Record Group
  - Record Set
  - Data Store
  - Object Group
177. Which of the following is not a parameter to SET\_BLOCK\_PROPERTY?
- Block Name
  - Property Name
  - Value
  - None of these

136. The output of the following program is

```
main()
{ static int x[] = {1, 2, 3, 4, 5, 6, 7, 8};
 int i;
 for(i = 2; i < 6; ++i)
 x[x[i]] = x[i];
 for (i = 0; i < 8; ++i)
 printf ("%d ", x[i]);
}
```

- 1 2 3 3 5 5 7 8
- 1 2 3 4 5 6 7 8
- 8 7 6 5 4 3 2 1
- 1 2 3 5 4 6 7 8

- \*137. main ()

```
{ int a = 5, b = 2;
 printf("%d", a+++b);
}
```

- results in syntax error
- prints 7
- prints 8
- none of the above

- \*138. The program fragment

```
int a = 5, b = 2;
printf ("%d", a++++b);
```

- prints 7
- prints 8
- prints 9
- none of the above

- \*139. Consider the following program

```
main()
{ int x = 2, y = 5;
 if (x < y) return (x = x + y);
 else printf ("z1");
 printf ("z2");
}
```

Choose the correct statements

- The output is z2
- The output is z1z2
- This will result in compilation error
- None of the above

- \*140. puts(argv[0]);

- prints the name of the source code file
- prints argv
- prints the number of command line arguments
- prints the name of the executable code file

141. A possible output of the following program fragment

```
static char wer[][5] = {"harmot", "merli", "axari"};
printf("%d %d %d", wer, wer[0], &wer[0][0]);
```

is



- (a) 262164 262164 262164      (b) 262164 262165 262166  
 (c) 262164 262165 262165      (d) 262164 262164 262165

\*142. The following program

```
main()
{printf("%u", main);}
results in
```

- (a) printing of a garbage number  
 (b) an execution error  
 (c) printing of starting address of the function main  
 (d) an infinite loop

\*143. The following program

```
main()
{ int abc();
 abc();
 (*abc)();
}
int abc()
{ printf("come"); }
```

- (a) results in a compilation error      (b) prints come come  
 (c) results in a run time      (d) prints come come

The next five questions are based on the following program fragment.

```
static char wer[3][4] = {"bag", "let", "bud"};
char(*ptr)[4] = wer;
```

\*144. The possible output of `printf("%d %d", ptr, ptr+1);` is

- (a) 262 262      (b) 262 266      (c) 262 263      (d) 262 265

145. The possible output of `printf("%d %d", wer[1], wer[1]+1);` is

- (a) 162 163      (b) 162 162      (c) 162 166      (d) 162 165

146. The possible output of `printf("%d %d", wer, wer+1);` is

- (a) 262 262      (b) 262 266      (c) 262 263      (d) 262 265

147. `putchar (*(wer[1]+1));`

- (a) prints e      (b) prints a      (c) prints l      (d) prints b

148. In which of the following cases will the character 't' be printed?

- (a) `putchar (*(ptr+1) + 2);`  
 (b) `putchar (*(wer[1] + 2));`  
 (c) `putchar (*(ptr+1) + 2);`  
 (d) none of the above

Questions 154 to 212 are from FORMS.

154. A compiled form module has the extension

- (a) fmb      (b) fmx      (c) exe      (d) obj

155. The attributes of a Form object can be found in the

- (a) layout editor      (b) program editor      (c) property navigator      (d) property palette

156. If the values of the properties of a RELATION in a master-detail Form violates the constraints set forth in the database tables then

- (a) it results in an error  
 (b) it results in a warning  
 (c) what is defined in the database overrides what is defined in the RELATION  
 (d) what is defined in the RELATION overrides what is defined in the database

157. Which of the following triggers can be used to disable the function keys?

- (a) WHEN-BUTTON-PRESSED Trigger      (b) KEY-NULLIFY Trigger  
 (c) WHEN-NEW-FORM-INSTANCE Trigger      (d) KEY-OTHERS Triggers

158. A canvas is displayed in

- (a) an enclosing canvas      (b) a tabbed page      (c) a dialog box      (d) a window

\*159. When a WHEN-VALIDATE-ITEM trigger fails, it

- (a) terminates the Form      (b) displays a message in a dialog box  
 (c) displays a message in the status line      (d) none of these

160. A Data Block in a Form can be based on a

- (a) table      (b) view      (c) stored procedure      (d) none of these

161. An LOV can be populated by

- (a) a record group      (b) a static list of values  
 (c) an object group      (d) an exception

162. During execution, the mode of a Data Block in a Form has to be

- (a) Normal or Query      (b) Normal or Enter Query  
 (c) Query or Enter Query      (d) Normal or Query or Enter Query

163. Trigger code is written in

- (a) SQL      (b) PL/SQL      (c) JAVA      (d) Machine Language

164. The default tab order of the items displayed in a Form is

- (a) determined by the physical ordering of the items in the object navigator  
 (b) determined by the order in which they are stored in the database table  
 (c) determined by their size  
 (d) unpredictable

165. Which of the following is typically used to inform the user of the occurrence of a specific event?

- (a) LOV      (b) Exception      (c) Alert      (d) Boiler Plate

166. In a master-detail Form, more number of records is usually displayed in the

- (a) master block      (b) detail block      (c) neither (a) nor (b)      (d) none of these

151. Consider the flowchart in Fig. 16.2.

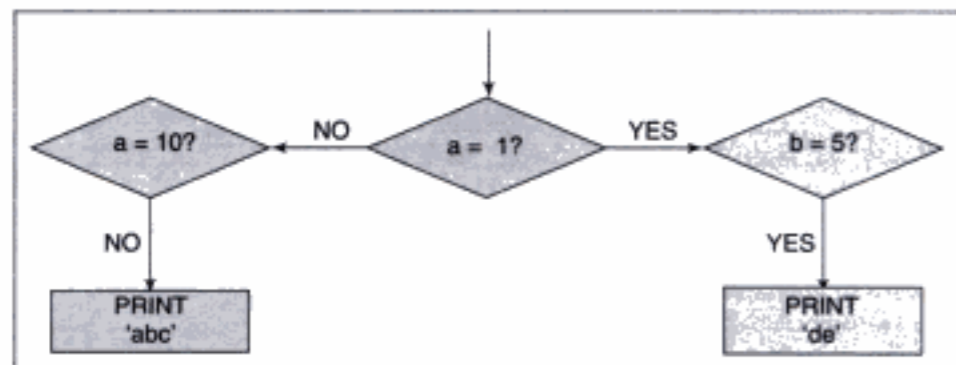

Fig. 16.2

Which of the following codes correctly implement this flowchart?

- (a) IF (a = 1) THEN  
BEGIN  
IF (b = 5) THEN  
DBMS\_OUTPUT.PUT\_LINE('de');  
END IF;  
END;  
ELSE IF (a <> 10) THEN  
DBMS\_OUTPUT.PUT\_LINE('abc');  
END IF;  
END IF;
- (b) IF (a = 1) THEN  
IF (b = 5) THEN  
DBMS\_OUTPUT.PUT\_LINE('de');  
ELSE IF (a <> 10) THEN  
DBMS\_OUTPUT.PUT\_LINE('abc');  
END IF;  
END IF;  
END IF;
- (c) IF (a = 1) THEN  
BEGIN  
IF (b = 5) THEN  
DBMS\_OUTPUT.PUT\_LINE('de');  
END IF;  
END;  
ELSE IF (a = 10) THEN  
NULL;  
ELSE DBMS\_OUTPUT.PUT\_LINE('abc');  
END IF;  
END IF;
- (d) None of these

152. Which of the following is not a collection type in PL/SQL?

- (a) Varrays (b) Index-By tables (c) Nested Tables (d) None of these

153. Which of the following is not a valid parameter mode?

- (a) IN (b) OUT (c) IN OUT (d) None of these

149. Choose the correct statements.

- (a) Address is the numeric value associated with a memory location.  
(b) Two variables can have the same address.  
(c) Address is bound to a variable by the compiler.  
(d) Value of a variable can be an address.

150. Feature for accessing a variable through its address is desirable because

- (a) call by reference can be simulated  
(b) call by value can be simulated  
(c) a function can return more than one value  
(d) excessive use of global variables can be avoided

151. `int i = 5;`

is a statement in a C program. Which of the following are true?

- (a) During execution, value of `i` may change but not its address  
(b) During execution both the address and value may change  
(c) Repeated execution may result in different addresses for `i`  
(d) `i` may not have an associated address

152. Choose the correct statements.

- (a) Address operator cannot be applied to register variables.  
(b) Address operator can be applied to register variables.  
(c) Misuse of register declaration will increase the execution time.  
(d) None of the above.

\*153. Choose the best answer.

Prior to using a pointer variable

- (a) it should be declared  
(b) it should be initialized  
(c) it should be both declared and initialized  
(d) none of the above

154. The operators `>` and `<` are meaningful when used with pointers, if

- (a) the pointers point to data of similar type  
(b) the pointers point to structure of similar data type  
(c) the pointers point to elements of the same array  
(d) none of these

155. A set of names can be represented as a

- (a) two-dimensional array of characters  
(b) one-dimensional array of strings  
(c) one-dimensional array of pointers to character  
(d) none of these

156. If `arr` is a two dimensional array of 10 rows and 12 columns, then `arr[5]` logically points to the

- (a) sixth row (b) fifth row (c) fifth column (d) sixth column

7. While sorting a set of names, representing the names as an array of pointers is preferable to representing the names as a two dimensional array of characters, because
- storage needed will be proportional to the size of the data
  - execution will be faster
  - swapping process becomes easier and faster
  - none of the above
8. The statement
- ```
int **a;
```
- is illegal
 - is legal but meaningless
 - is syntactically and semantically correct
 - none of the above
9. Consider the following declaration.
- ```
int a, *b = &a, **c = &b;
```
- The following program fragment
- ```
a = 4;
**c = 5;
```
- does not change the value of a
 - assigns address of c to a
 - assigns the value of b to a
 - assigns 5 to a
10. If the statement
- ```
b = (int *)**c;
```
- is appended to the above program fragment, then
- value of b is unaffected
  - value of b will be the address of c
  - value of b becomes 5
  - none of these
11. Consider the two declarations
- ```
void *voidPtr ;
char *charPtr ;
```
- Which of the following assignments are syntactically correct?
- voidPtr = charPtr
 - charPtr = voidPtr
 - *voidPtr = *charPtr
 - *charPtr = voidPtr
12. Which of the following operators can be applied to pointer variable(s)?
- Division
 - Multiplication
 - Casting
 - None of these
13. Pointers are of
- integer datatype
 - character datatype
 - unsigned integer datatype
 - none of these
14. The address operator &, cannot act on
- R-values
 - arithmetic expressions
 - members of a structure
 - local variables

138. Consider the declaration
- ```
abc tableName%ROWTYPE;
```
- The field names of abc
- are undefined
  - are \$1, \$2, ...
  - will be the column names of tableName
  - none of these
- \*139. Which of these are true of Collection types?
- They store data of the same data type.
  - They are sparse.
  - They are unconstrained.
  - They can store data of different data type.
140. Which of the following keywords is used in the declaration of a PL/SQL function but not a procedure?
- RETURN
  - BEGIN
  - END
  - EXCEPTION
141. Which of the following are cursor operations?
- OPEN
  - CLOSE
  - FETCH
  - DECLARE
142. Choose the correct statements.
- ROWCOUNT of an implicit cursor gives the total number of rows matched by the query.
  - ROWCOUNT of an explicit cursor gives the total number of rows fetched so far.
  - ROWCOUNT of an implicit cursor gives the total number of rows fetched so far.
  - ROWCOUNT of an explicit cursor gives the total number of rows matched by the query.
143. In PL/SQL
- a block can access variables that are declared in the enclosing block
  - a block can access variables that are declared in the enclosed block
  - a block cannot access variables that are declared in the enclosing block
  - a block cannot access variables that are declared in the enclosed block
144. Which of the following are pre-defined error conditions?
- NO\_DATA\_FOUND
  - TOO\_MANY\_ROWS
  - CASE\_NOT\_FOUND
  - DUP\_VAL\_ON\_INDEX
145. Choose the correct statements.
- In a PL/SQL code
- if the current block is not having the exception handler, the enclosing block will be searched for one



125. Statement 7 cannot be replaced by the statement  
 (a) my\_proc(input2, input1, input3); (b) my\_proc(input2, input2, input2);  
 (c) my\_proc(input3, input1, input2); (d) none of these
126. Statement 7 cannot be replaced by the statements  
 (a) my\_proc(2, 3, 4); (b) my\_proc(2, input3, input2);  
 (c) my\_proc(2, 3, input3); (d) all of these
127. Suppose a procedure my\_proc is created with no formal parameter. Which of the following calls is correct?  
 (a) my\_proc (b) my\_proc; (c) my\_proc( ) (d) my\_proc( );
128. Which of the following cannot be anonymous?  
 (a) Procedure (b) Function (c) Package (d) None of these
129. The design of PL/SQL language has a lot of similarities with the design of  
 (a) COBOL (b) ORACLE (c) ADA (d) LISP
130. Which of the following formal parameter declarations (inside the definition of a PL/SQL procedure or function) are not acceptable?  
 (a) last\_name IN OUT VARCHAR2(30) (b) last\_name IN VARCHAR2  
 (c) last\_name IN VARCHAR2 (d) last\_name OUT VARCHAR2(30)
131. Which of the following can be used to print the description about an error in a PL/SQL program?  
 (a) SQLERRM (b) ERR\_MESG (c) CURR\_ERROR (d) DISP\_ERR
132. If a function does not modify the database state, its purity level is  
 (a) RNDS (b) WNPS (c) RNPS (d) WNDS
133. Which of the following types of triggers can be fired on DDL operations?  
 (a) Instead-Of Trigger (b) DML Trigger (c) system Trigger (d) DDL Trigger
134. If a trigger is fired by an INSERT statement, the values of :old and :new are respectively  
 (a) NULL and the value that is inserted  
 (b) a garbage value and the value that is inserted  
 (c) NULL and NULL  
 (d) the value that is inserted and the value that is inserted
135. To have a variable in global scope, declare it inside a  
 (a) function (b) procedure (c) package (d) none of these
136. In a PL/SQL code, uninitialized variables of type VARCHAR2 will have  
 (a) garbage value (b) NULL value (c) 0 value (d) none of these
137. Choose the correct statements.  
 (a) The n in CHAR(n) can be missing in the declaration.  
 (b) The n in CHAR(n) is mandatory in the declaration.  
 (c) If the n in CHAR(n) is missing in the declaration, it defaults to 1.  
 (d) If a 5 character string is stored in a variable that had been declared as CHAR(10), the string will be right padded with blanks to make it a 10 character string.

165. Consider the following program fragment.  

```
int v = 3, *pv = &v;
printf ("%d %d", v, *pv);
```

 The output will be  
 (a) an error message (b) 3 address of v  
 (c) 3 3 (d) none of the above
166. If the two statements  

```
*pv = 0;
printf ("%d %d", *pv, v);
```

 are appended to the previous program fragment, then the output will be  
 (a) 0 3 (b) 0 0  
 (c) unpredictable (d) none of the above
167. A pointer variable can be  
 (a) passed to a function as argument (b) changed within a function  
 (c) returned by a function (d) can be assigned an integer value
168. A string that is a formal parameter can be declared  
 (a) an array with empty bracket (b) a pointer to character  
 (c) a pointer to a character (d) none of the above
169. Choose the correct statements.  
 (a) An entire array can be passed as argument to a function.  
 (b) A part of an array can be passed as argument to a function.  
 (c) Any change done to an array that is passed as an argument to a function will be local to the function.  
 (d) None of these.
170. Consider the following program.  

```
main()
{
 char x[10], *ptr = x;
 scanf ("%s", x);
 change(&x[4]);
}
change(char a[])
{puts(a);}
```

 If abcdefg is the input, the output will be  
 (a) abcd (b) abc (c) efg (d) garbage
171. For the previous problem the function calls  

```
change(x); and change(ptr);
```

 (a) serves the same purpose (b) the second call is illegal  
 (c) both the calls are illegal (d) none of the above



2. If  $x$  is an array of integer, then the value of  $\&x[i]$  is same as that of  
 (a)  $\&x[i-1] + \text{sizeof}(\text{int})$  (b)  $x + \text{sizeof}(\text{int}) * i$   
 (c)  $x + i$  (d)  $++(\&x[i])$
3. Pick the correct answers.  
 If  $x$  is an one dimensional array, then  
 (a)  $\&x[i]$  is same as  $x + i - 1$   
 (b)  $*(x + i)$  is same as  $\&x[i]$   
 (c)  $*(x + i)$  is same as  $x[i]$   
 (d)  $*(x + i)$  is same as  $*x + i$
4. Let  $x$  be an array. Which of the following cannot be present in the left hand side of an assignment statement?  
 (a)  $x$  (b)  $x + i$  (c)  $*(x + i)$  (d)  $\&x[i]$
5. Let  $x$  be an array. Which of the following operations are illegal?  
 (a)  $++x$  (b)  $x + 1$  (c)  $x++$  (d)  $x * 2$
6. Consider the declaration  

```
char x[] = "WHATIZIT";
char *y = "WHATIZIT";
```

 Pick the correct answers.  
 (a) The output of  $\text{puts}(x)$  and  $\text{puts}(y)$  will be the same.  
 (b) The output of  $\text{puts}(x)$  and  $\text{puts}(y)$  will be different.  
 (c) The output of  $\text{puts}(y)$  is implementation dependent.  
 (d) None of the above comments are true.
7. If  $\text{func}$  is a function needing three arguments  $a_1, a_2, a_3$ , then  $\text{func}$  can be invoked by  
 (a)  $\text{func}(a_1, a_2, a_3);$  (b)  $(*\text{func})(a_1, a_2, a_3);$   
 (c)  $*\text{func}(a_1, a_2, a_3);$  (d) all of the above
8. Consider the declarations  

```
char first(int (*) (char, float));
int second(char, float);
```

 Which of the following function invocation is valid?  
 (a)  $\text{first}(*\text{second});$  (b)  $\text{first}(\&\text{second});$   
 (c)  $\text{first}(\text{second});$  (d) none of the above
9. The declaration  

```
int (*p) [5];
```

 means  
 (a)  $p$  is a one dimensional array of size 5, of pointers to integers  
 (b)  $p$  is a pointer to a 5 element integer array  
 (c) the same as  $\text{int } *p[5];$   
 (d) none of the above

- (b)  $\text{DECODE}(\text{MOD}(\text{YEAR}, 4),$   
 $0, \text{DECODE}(\text{MOD}(\text{YEAR}, 100)$   
 $, 0, \text{DECODE}(\text{MOD}(\text{YEAR}, 400)$   
 $, 0, 'NLY'$   
 $, 'LY')$   
 $, 'LY')$   
 $, 'NLY')$
- (c)  $\text{DECODE}(\text{MOD}(\text{YEAR}, 4),$   
 $0, \text{DECODE}(\text{MOD}(\text{YEAR}, 100)$   
 $, 0, \text{DECODE}(\text{MOD}(\text{YEAR}, 400)$   
 $, 0, 'LY'$   
 $, 'NLY')$   
 $, 'NLY')$
- (d) None of these
- \*103. Table Employee has 10 records. It has a non-NULL SALARY column which is also UNIQUE. The SQL statement  

```
SELECT COUNT(SALARY) FROM EMPLOYEE WHERE SALARY NOT IN (NULL);
```

 prints,  
 (a) 10 (b) 9 (c) 5 (d) 0
104. The FROM clause -  $\text{EMPLOYEE LEFT OUTER JOIN DEPARTMENT}$   
 (a) includes all employees not assigned to any department  
 (b) includes all departments having no employee  
 (c) includes only those employees who are assigned a department  
 (d) none of these
105. Which of the following SQL commands can be used to modify existing data in a database table?  
 (a) MODIFY (b) UPDATE (c) CHANGE (d) NEW
- \*106. Let the statement  

```
SELECT * FROM nameList;
```

 return 10 rows. The statement  

```
SELECT * FROM nameList WHERE ROWNUM > 5;
```

 will return  
 (a) 4 rows (b) 5 rows (c) 6 rows (d) none of these
- \*107. The SELECT statement  

```
SELECT 'Hi' FROM DUAL WHERE NULL IN (NULL);
```

 outputs,  
 (a) TRUE (b) FALSE (c) 'Hi' (d) nothing

\*90. The SQL statement

```
SQL> SELECT A.From, B.From FROM train_info A, train_info B
 GROUP BY(A. From, B. From)
 HAVING A.From = 'Vijayawada';
```

will print,

- (a) 3 records            (b) 4 records            (c) 5 records            (d) 6 records

\*91. Choose the correct statements.

- (a) Column alias cannot be used in the ORDER BY clause  
 (b) Column alias can be used in the ORDER BY clause  
 (c) Column alias can be used in the WHERE clause  
 (d) Column alias cannot be used in the WHERE clause

\*92. The WHERE clause - WHERE city LIKE '%a\\_%b'

cannot display

- (a) ab                    (b) abb                    (c) a\_b                    (d) a\_%b

\*93. Choose the correct statements.

- (a) FALSE AND NULL is FALSE            (b) TRUE AND NULL is NULL  
 (c) NOT NULL is NULL                    (d) FALSE OR NULL is NULL

\*94. Choose the correct statement that is based on a SQL query that has its ORDER BY clause defined as ORDER BY name, game DESC

- (a) Vijay, Golf will be listed before Anand, Chess  
 (b) Anand, Chess will be listed before Vijay, Golf  
 (c) Bhupathi, Tennis will be listed before Anand, Chess  
 (d) Bhupathi, Tennis will be listed before Vijay, Golf

\*95. Which of the following SELECT statements print the string 56?

- (a) SELECT SUBSTR('123456', 5) FROM DUAL ;  
 (b) SELECT SUBSTR('123456', -2) FROM DUAL ;  
 (c) SELECT SUBSTR('123456', 5, 2) FROM DUAL ;  
 (d) SELECT SUBSTR('123456', -2, 2) FROM DUAL ;

\*96. The SQL statement

```
SELECT LPAD('abcd',10,'wert') FROM DUAL ;
```

prints,

- (a) wertweabcd            (b) abcdwertwer            (c) wertwertab            (d) abwertwert

\*97. The SQL statement

```
SELECT ROUND(45.926, -2) FROM DUAL ;
```

- (a) is illegal            (b) prints garbage            (c) prints 45.92            (d) prints 0

\*98. Choose the correct statements.

The SQL statement

```
SELECT SYSDATE FROM DUAL ;
```

180. A function q that accepts a pointer to a character as argument and returns a pointer to an array of integer can be declared as

- (a) int(\*q(char\*))[]                    (b) int \*q(char \*)[]  
 (c) int(\*q)(char \*)[]                    (d) none of the above

\*181. Consider the declaration

```
int a = 5, *b = &a;
```

The statement

```
printf("%d", a * b);
```

prints

- (a) 25                    (b) garbage                    (c) 5 × address of b            (d) an error message

\*182. In the previous question, printf("%d", a\*\*b); prints

- (a) 25                    (b) garbage                    (c) 0                    (d) an error message

183. The following program

```
main()
{
 float a = .5, b = .7;
 if (b < .7)
 if (a < .5)
 printf("TELO");
 else
 printf("LTTE");
 else
 printf("JKLF");
}
```

outputs

- (a) LTTE                    (b) TELO                    (c) JKLF                    (d) PLO

184. What is the output of the following program segment?

```
void max(int x, int y, int m)
{ if(x > 5) m = x;
 else m = y;}
int main()
{ int i = 20, j = 5, k = 0;
 max(i, j, k); printf("%d", k); }
```

- (a) 5                    (b) 20                    (c) 0                    (d) none of the above

185. Consider the program

```
main()
{
 int y = 1 ;
 printf("%d", (*(char *)&x)) ;
}
```

If the machine in which this program is executed is little-endian (meaning, the lower significant digits occupy lower addresses), then the output will be

- (a) 0 (b) 99999999 (c) 1 (d) unpredictable

186. Choose the correct statements.

- (a) Array stores data of the same type (b) Array can be a part of a structure  
(c) Array of structure is allowed (d) Structure stores data of the same type

187.  $a \rightarrow b$  is syntactically correct if

- (a) a and b are structures  
(b) a is a structure and b is a pointer to a structure  
(c) a is a pointer to a structure and b is a structure  
(d) a is a pointer to a structure in which b is a field

188. A file is preferable to an array of structures because

- (a) file lives even after the program that created it terminates  
(b) memory space will not be wasted  
(c) there are many system tools to manipulate files  
(d) there are language as well as system features to deal with files

189. The program

```
main()
{
 int i = 5;
 i = (++i) / (i++);
 printf("%d", i);
}
```

prints

- (a) 2 (b) 5 (c) 1 (d) 6

190. If a file is opened in  $r+$  mode then

- (a) reading is possible (b) writing is possible  
(c) it will be created if it does not exist (d) all the above comments are true

191. `ftell`

- (a) is a function  
(b) gives the current file position indicator  
(c) can be used to find the size of a file  
(d) is meant for checking whether a given file exists or not

192. If a file is opened in  $w+$  mode then

- (a) appending is possible  
(b) reading is possible  
(c) writing is possible  
(d) after write operation reading is possible without closing and re-opening.

76. The SQL statement

SELECT DECODE(2, 2, DECODE(3, 3, 2)) FROM DUAL;

- (a) is illegal (b) prints garbage (c) 3 (d) 2

\*77. Which of the following joins is also called as an 'inner join'?

- (a) Non-Equijoin (b) Self-Join (c) Equijoin (d) None of these

The next 13 questions (78–90) are based on the following table.

Consider the following table. (Table Name: train\_info)

| TrainNum | From       | To         | Through1   | Through2 | Through3 |
|----------|------------|------------|------------|----------|----------|
| 1        | Chennai    | New Delhi  | Vijayawada | Jhansi   | Agra     |
| 2        | Vijayawada | New Delhi  | Jhansi     | Agra     |          |
| 3        | Hyderabad  | Kanpur     | Vijayawada | Jhansi   |          |
| 4        | Hyderabad  | Kanpur     | New Delhi  | Agra     |          |
| 5        | Vijayawada | Agra       | Hyderabad  | Jhansi   | Kanpur   |
| 6        | Chennai    | Vijayawada |            |          |          |

78. The SQL statement

SQL> SELECT COUNT(\*) FROM train\_info  
WHERE through1 LIKE '%ad%';

will print,

- (a) 1 (b) 2 (c) 3 (d) 4

\*79. How many record(s) will be printed by the following SQL query?

SQL> SELECT A.From, B.To FROM train\_info A, train\_info B  
WHERE A.To = B.From;

- (a) No record (b) 1 record (c) 2 records (d) None of these

80. The SQL statement

SQL> SELECT COUNT(\*) FROM train\_info A, train\_info B  
WHERE A.start\_city = B.start\_city AND A.destination\_city = B.destination\_city;

will print,

- (a) 6 (b) 7 (c) 8 (d) none of these

81. The SQL statement

SQL> SELECT COUNT(\*) FROM train\_info A, train\_info B  
WHERE A.start\_city = B.start\_city AND A.destination\_city = B.destination\_city  
AND A.trainNum <> B.trainNum;

will print,

- (a) 0 (b) 1 (c) 2 (d) none of these

82. The SQL statement

SQL> SELECT COUNT(\*) FROM train\_info A, train\_info B, train\_info C;

will print,

- (a) 6 (b) 18 (c) 12 (d) 216



68. The SQL statement  
SELECT INSTR('abcdecfg', 'c') FROM DUAL ;  
prints,  
(a) 2 (b) 3 (c) 5 (d) 6
69. The SQL statement  
SELECT LPAD('abcd',10,'\*') FROM DUAL ;  
prints,  
(a) abcd\*\*\*\*\* (b) \*\*\*\*\*abcd (c) \*\*\*abcd\*\*\* (d) \*\*\*\*\*
70. Table EMPLOYEE has 5 rows. Consider the following sequence of SQL statements.  
SQL> CREATE TABLE myTable AS (SELECT \* FROM EMPLOYEE);  
SQL> INSERT INTO myTable SELECT \* FROM myTable;  
SQL> INSERT INTO myTable SELECT \* FROM myTable;  
SQL> INSERT INTO myTable SELECT \* FROM myTable;  
SQL> INSERT INTO myTable SELECT \* FROM myTable;  
If the SQL statement  
SELECT COUNT(\*) FROM MYEMP;  
is executed after executing all the statements listed above, what will be printed is  
(a) 80 (b) 25 (c) 20 (d) 5
71. Let the statement  
SELECT column1 FROM myTable;  
return 10 rows. The statement  
SELECT ALL column1 FROM myTable;  
will return  
(a) less than 10 rows (b) more than 10 rows  
(c) exactly 10 rows (d) none of these
72. The SQL statement  
SELECT (NVL(NVL(NULL, 3), 4)) FROM DUAL;  
(a) prints 3 (b) prints 4 (c) prints NULL (d) is illegal
73. Table Employee has 10 records. It has a non-NULL SALARY column which is also UNIQUE.  
The SQL statement  
SELECT COUNT(\*) FROM EMPLOYEE WHERE SALARY > ALL (SELECT SALARY FROM EMPLOYEE);  
prints  
(a) 10 (b) 9 (c) 5 (d) 0
74. The SELECT statement  
SELECT 'Hi' FROM DUAL WHERE 1 != NULL;  
outputs  
(a) Hi (b) FALSE (c) TRUE (d) nothing
75. Which of the following SQL commands can be used to add data to a database table?  
(a) ADD (b) UPDATE (c) APPEND (d) INSERT

193. The fseek function  
(a) needs 2 arguments  
(b) makes the rewind function unnecessary  
(c) is meant for checking whether a given file exists or not  
(d) needs 3 arguments
194. The statement fseek(fp, 0L, 0); - if syntactically correct, means  
(a) fp is a file pointer  
(b) position the read-write-head at the start of the file  
(c) position the read-write-head at the end of the file  
(d) erase the contents of the file
195. The contents of a file will be lost if it is opened in  
(a) a mode (b) w mode (c) w+ mode (d) a+ mode
196. Which of the following comments about union are true?  
(a) Union is a structure whose members share the same storage area.  
(b) The compiler will keep track of what type of information is currently stored.  
(c) Only one of the members of union can be assigned a value at a particular time.  
(d) Size allocated for union is the size of its member needing the maximum storage.
197. Which of the following comments about the usage of structure is true?  
(a) Storage class can be assigned to an individual member.  
(b) Individual members can be initialized within a structure type declaration.  
(c) The scope of a member name is confined to the particular structure, within which it is defined.  
(d) None of the above.

Answer the next 4 questions, based on the following declaration.

```
struct addr
{
char city[10];
char street[20];
int pincode;
};
struct
{
char name[20];
int sex;
struct addr locate ;
} criminal, *kd = &criminal;
```

198. sex can be accessed by  
(a) criminal.sex (b) kd → sex  
(c) (\*kd).sex (d) either (a) or (c), but not by (b)



199. pincode can be accessed by  
 (a) criminal.locate.pincode  
 (b) criminal.pincode  
 (c) kd → locate.pincode  
 (d) kd.locate → pincode
200. The third character in the criminal name can be accessed by  
 (a) criminal.name[2] (b) kd → name[2]  
 (c) ((\*kd).name)[2] (d) either (b) or (c), but not by (a)
201. \*(kd → name + 2) can be used instead of  
 (a) \*(criminal.name + 2) (b) kd → (name + 2)  
 (c) \*((\*kd).name + 2) (d) either (a) or (b), but not (c)
202. How many bits are absolutely necessary to store an ASCII character?  
 (a) 7 (b) 8 (c) 16 (d) 15
203. If 7 bits are used to store a character, the percentage reduction of needed storage will be  
 (a) 22.5 (b) 2.5 (c) 8 (d) 12.5
204. Bit field  
 (a) is a field having many sub-fields  
 (b) is a structure declaring the sizes of the members in terms of bits  
 (c) is a member of a structure whose size is specified in terms of bits  
 (d) none of the above
205. Choose the correct comments.  
 In a bit-field  
 (a) a field can be un-named  
 (b) a field can be of width 0  
 (c) if a field is un-named, its width must not be zero  
 (d) a field must have a name
206. The declaration  

```
int x : 4;
```

 means  
 (a) x is a four digit integer  
 (b) x cannot be greater than a four digit integer  
 (c) x is a four-bit integer  
 (d) none of the above
207. Bit-fields will be accommodated in a word  
 (a) from left to right  
 (b) from right to left  
 (c) in a way that depends on the implementation  
 (d) none of the above

- How many rows will be displayed by the following query?  

```
SELECT DISTINCT(A.CustNum)
FROM CustInfo A, OrderInfo B
WHERE A.OrderNum = B.OrderNum
 AND SUBSTR(TO_CHAR(B.OrderDate), 8) = (SELECT SUBSTR(TO_CHAR(SYSDATE), 8) FROM DUAL);
```

 (a) 1 (b) 2 (c) 3 (d) 4
61. Which of the following combinations of wildcard characters has the same meaning as the wildcard character %?  
 (a) %% (b) \_% (c) %\_ (d) \_\_
- \*62. The SELECT statement  

```
SELECT 'Hi' FROM DUAL WHERE NULL = NULL;
```

 outputs  
 (a) Hi (b) FALSE (c) TRUE (d) nothing
- \*63. Which of the following is illegal?  
 (a) SELECT SYSDATE - SYSDATE FROM DUAL ;  
 (b) SELECT SYSDATE - (SYSDATE - 2) FROM DUAL ;  
 (c) SELECT SYSDATE - (SYSDATE + 2) FROM DUAL ;  
 (d) None of these
64. When a SELECT statement displays data  
 (a) dates and strings will be justified to the left by default  
 (b) numbers will be justified to the right by default  
 (c) dates and strings will be justified to the right by default  
 (d) numbers will be justified to the left by default
65. If a query involves NOT, AND, OR with no parenthesis  
 (a) NOT will be evaluated first; AND will be evaluated second; OR will be evaluated last.  
 (b) NOT will be evaluated first; OR will be evaluated second; AND will be evaluated last.  
 (c) AND will be evaluated first; OR will be evaluated second; NOT will be evaluated last.  
 (d) the order of occurrence determines the order of evaluation.
66. Choose the correct statements.  
 (a) ORDER BY NAME ASC, displays NULLs last  
 (b) ORDER BY NAME DESC, displays NULLs first  
 (c) ORDER BY NAME ASC, displays NULLs first  
 (d) ORDER BY NAME DESC, displays NULLs last
- \*67. The SQL statement  

```
SELECT LENGTH('') FROM DUAL ; -- '' is two single quotes
```

 prints,  
 (a) 0 (b) a garbage value (c) NULL (d) 1

56. Which of the following remarks about the following query are true?

```
SELECT DISTINCT(A.CustNum)
FROM CustInfo A, OrderInfo B
WHERE A.OrderNum = B.OrderNum
 AND B.OrderedItem = (SELECT C.ItemName
 FROM ItemInfo C
 WHERE C.UnitPrice = (SELECT Max(C.UnitPrice)
 FROM ItemInfo C));
```

- (a) This query is syntactically wrong  
 (b) It returns 5 rows  
 (c) One of the CustNum returned is 1008  
 (d) It returns all CusNum that ordered a table

57. Which of the listed options can fill the blank if the following query displayed exactly 6 rows?

```
SELECT DISTINCT(A.CustNum)
FROM CustInfo A, OrderInfo B
WHERE A.OrderNum = B.OrderNum
 AND B.OrderedItem IN (SELECT C.ItemName
 FROM ItemInfo C
 WHERE C.UnitPrice > ____);
```

- (a) 2                      (b) 8                      (c) 20                      (d) 30

58. What is the CustNum that will be displayed by the following query?

```
SELECT DISTINCT(A.CustNum)
FROM CustInfo A, OrderInfo B
WHERE A.OrderNum = B.OrderNum
 AND B.OrderDate = (SELECT MAX(C.OrderDate)
 FROM OrderInfo C);
```

- (a) 1001                      (b) 1002                      (c) 1003                      (d) 1004

59. How many rows are returned by the following query?

```
SELECT DISTINCT(A.CustNum)
FROM CustInfo A, OrderInfo B
WHERE A.OrderNum = B.OrderNum
 AND B.OrderDate BETWEEN '11-JUN-04' AND '02-FEB-05' ;
```

- (a) 4                      (b) 5                      (c) 6                      (d) 7

60. The query

```
SELECT SYSDATE FROM DUAL;
displays
02-FEB-05
```

Answer the next four questions assuming that bit-fields are accommodated from right to left and word size is 16 bits.

\*208. Consider the declaration

```
static struct {
 unsigned a:5;
 unsigned b:5;
 unsigned c:5;
 unsigned d:5;
} v = {1, 2, 3, 4};
```

v occupies

- (a) 4 words                      (b) 2 words                      (c) 1 word                      (d) none of the above

209. In the previous question, information about d will be in the

- (a) first word                      (b) second word                      (c) in both words                      (d) none of the above

\*210. If the declaration unsigned c:5; is replaced by unsigned:6; then,

- (a) it results in a syntax error  
 (b) it is meaningless  
 (c) the compiler will give a new name for the field, which can be used in the program  
 (d) none of the above

\*211. Consider the declaration

```
struct wer { unsigned a:5;
 unsigned:0;
 unsigned b:3;
 unsigned:0;
 unsigned c:2;
 unsigned:0; } v;
```

The storage needed for v is

- (a) 1 word                      (b) 2 words                      (c) 3 words                      (d) 4 words

\*212. The above declaration is

- (a) syntactically correct                      (b) semantically correct  
 (c) a misuse of bit-fields                      (d) none of the above

213. Which of the following is not a low-level feature of C?

- (a) Register storage class                      (b) Bit-fields  
 (c) Bit-wise operations                      (d) None of the above

214. C preprocessor

- (a) takes care of conditional compilation                      (b) takes care of macros  
 (c) takes care of include files                      (d) acts before compilation

215. A preprocessor command

- (a) need not start on a new line                      (b) need not start on the first column  
 (c) has # as the first character                      (d) comes before the first executable statement

216. Choose the correct statement.
- (a) The scope of a macro definition need not be the entire program.
  - (b) The scope of a macro definition extends from the point of definition to the end of the file.
  - (c) New line is a macro definition delimiter.
  - (d) A macro definition may go beyond a line.

217. The use of macro in the place of functions

- (a) reduces execution time
- (b) reduces code size
- (c) increases execution time
- (d) increases code size

218. The output of the following program

```
main()
{ int a = 1, b = 2, c = 3;
 printf("%d", a += (a += 3), 5, a);
}
```

will be

- (a) 8
- (b) 12
- (c) 9
- (d) 6

219. The process of transforming one bit pattern into another by bit-wise operations is called

- (a) masking
- (b) pruning
- (c) biting
- (d) chopping

220. Consider the following program segment.

```
char *a, *b, c[10], d[10];
a = b;
b = c;
c = d;
d = a;
```

Choose the statements having errors.

- (a) No error
- (b) a = b; and b = c;
- (c) c = d; and d = a;
- (d) a = b; and d = a;

221. The operation of a staircase switch best explains the

- (a) or operation
- (b) and operation
- (c) exclusive nor operation
- (d) exclusive or operation

222. a << 1 is equivalent to

- (a) multiplying a by 2
- (b) dividing a by 2
- (c) adding 2 to a
- (d) none of the above

223. The most significant bit will be lost in which of the following operations?

- (a) >>
- (b) complementation
- (c) >>
- (d) none of the above

224. Assume an unsigned integer occupies 1 byte. Let myVar be an unsigned integer. Then myVar << 1 multiplies myVar by 2 if it is not greater than

- (a) 127
- (b) 255
- (c) 256
- (d) 128

48. Fill the blanks in the following query that finds the number of customers who ordered for either pen or pencil.

```
SELECT COUNT(_____ A.CustNum)
FROM CustInfo A, OrderInfo B
WHERE A.OrderNum = B.OrderNum
 _____ B.OrderedItem _____ ('Pen', 'Pencil');
```

- (a) ALL, AND, NOT IN
- (b) ALL, OR, IN
- (c) DISTINCT, AND, IN
- (d) DISTINCT, OR, IN

\*49. Which of the following CustNum will not be displayed by the following SQL query?

```
SELECT A.CustNum
FROM CustInfo A, OrderInfo B
WHERE A.OrderNum = B.OrderNum
 AND B.OrderedItem = 'Pen'
```

UNION

```
SELECT A.CustNum
FROM CustInfo A, OrderInfo B
WHERE A.OrderNum = B.OrderNum
 AND B.OrderedItem = 'Pencil';
```

- (a) 1006
- (b) 1007
- (c) 1008
- (d) 1009

\*50. How many rows will be displayed by the following SQL query?

```
SELECT A.CustNum
FROM CustInfo A, OrderInfo B
WHERE A.OrderNum = B.OrderNum
 AND B.OrderedItem = 'Pen'
```

UNION ALL

```
SELECT A.CustNum
FROM CustInfo A, OrderInfo B
WHERE A.OrderNum = B.OrderNum
 AND B.OrderedItem = 'Pencil';
```

- (a) 7
- (b) 8
- (c) 9
- (d) 10

\*51. Which CustNum will not be displayed by the following SQL query?

```
SELECT A.CustNum
FROM CustInfo A, OrderInfo B
WHERE A.OrderNum = B.OrderNum
 AND B.OrderedItem = 'Pen'
```

INTERSECT

```
SELECT A.CustNum
FROM CustInfo A, OrderInfo B
WHERE A.OrderNum = B.OrderNum
 AND B.OrderedItem = 'Pencil';
```

- (a) 1001
- (b) 1002
- (c) 1006
- (d) 1009

40. The SQL statement

```
SELECT SYSDATE FROM DUAL;
```

prints

06-FEB-05

Consider the three SQL statements

```
SELECT TO_DATE((LTRIM (RTRIM('NOV 23, 2005'))), 'Mon DD, YY') FROM DUAL;
```

— Statement 1

```
SELECT TO_DATE((RTRIM (LTRIM(' NOV 23, 2005 '))), 'Mon DD, YY') FROM DUAL;
```

— Statement 2

```
SELECT TO_DATE('NOV 23, 2005', 'Mon DD, YY') FROM DUAL; — Statement 3
```

Which of these statements gives the same output?

- (a) Only Statement 1 and Statement 2    (b) Only Statement 1 and Statement 3  
(c) Only Statement 2 and Statement 3    (d) All the three statements give the same output

The next 20 questions (41-60) are based on the following three tables.

Table Name: CustInfo

| CUSTNUM | CITY   | ORDERNUM |
|---------|--------|----------|
| 1001    | Kanpur | 2001     |
| 1002    | Vizag  | 2002     |
| 1003    | Guntur | 2003     |
| 1004    | Agra   | 2004     |
| 1005    | Guntur | 2005     |
| 1006    | Pune   | 2006     |
| 1007    | Guntur | 2007     |
| 1008    | Pune   | 2008     |
| 1009    | Delhi  | 2009     |
| 1010    | Imphal | 2010     |

Table Name: OrderInfo

| ORDERNUM | ORDERDATE | ORDEREDITEM | QUANTITY |
|----------|-----------|-------------|----------|
| 2001     | 02-FEB-05 | Pen         | 5        |
| 2001     | 02-FEB-05 | Pencil      | 3        |
| 2002     | 13-JAN-05 | Pen         | 3        |
| 2002     | 13-JAN-05 | Pencil      | 8        |
| 2003     | 11-JAN-05 | Table       | 1        |
| 2004     | 11-JUN-04 | Chair       | 4        |
| 2005     | 11-JAN-04 | Table       | 1        |
| 2006     | 17-APR-01 | Pen         | 10       |
| 2007     | 21-JUL-04 | Pencil      | 20       |
| 2008     | 15-JAN-05 | Table       | 2        |
| 2009     | 10-OCT-02 | Table       | 1        |
| 2009     | 10-OCT-02 | Pen         | 1        |
| 2009     | 10-OCT-02 | Pencil      | 1        |
| 2010     | 18-OCT-03 | Table       | 1        |

225. If the bit pattern corresponding to a signed integer is shifted to the right then
- (a) vacant bit will be filled by the sign bit  
(b) vacant bit will be filled by 0  
(c) the outcome is implementation dependent  
(d) none of the above
- \*226. In a certain machine, the sum of an integer and its 1's complement is  $2^{20} - 1$ . Then `sizeof(int)`, in bits, will be
- (a) 16                      (b) 32                      (c) unpredictable                      (d) none of the above
227. If the word size is 16 bit, then `~0xc5` will be
- (a) 0x3a                      (b) 0xff3a                      (c) 0x5c                      (d) none of the above
228. Which of the following operations produce an 1, if the input bits are 1 and 1?
- (a) or                      (b) and                      (c) exclusive or                      (d) exclusive nor
229. Preprocessing is typically done
- (a) either before or at the beginning of the compilation process  
(b) after compilation but before execution  
(c) after loading  
(d) none of the above
230. Which of the following comments about the preprocessor directive # are correct?
- (a) It converts the formal argument in the macro definition into a string.  
(b) It strips out redundant blanks.  
(c) It concatenates adjacent strings, if any.  
(d) None of the above.
231. The scope of a macro definition
- (a) cannot be beyond the file in which it is defined  
(b) may be part of a file  
(c) is the entire program  
(d) excludes string of characters within double quotes
232. The number of possible values of m, such that `m & 0x3f` equals `0x23` is
- (a) 1                      (b) 2                      (c) 3                      (d) 4
- \*233. The for loop
- ```
for(i = 0; i < 10; ++i)
    printf("%d", i & 1);
```
- prints
- (a) 0101010101 (b) 0111111111 (c) 0000000000 (d) 1111111111
234. As soon as a pointer variable is freed, its value
- (a) is set to null (b) becomes unpredictable
(c) is set to 1 (d) remains the same

235. `calloc(m, n)`; is equivalent to
 (a) `malloc(m*n, 0)`;
 (b) `memset(0, m*n)`;
 (c) `ptr = malloc(m*n); memset(p, 0, m*n)`;
 (d) `ptr = malloc(m*n); strcpy(p, 0)`;
236. Which of the following comments are correct when a macro definition includes arguments?
 (a) The opening parenthesis should immediately follow the macro name.
 (b) There should be at least one blank between the macro name and the opening parenthesis.
 (c) There should be only one blank between the macro name and the opening parenthesis.
 (d) All the above comments are correct.
237. Consider the program fragment

```

j = 2;
while ((i % j) != 0)
  j = j + 1;
if (j < i) printf ("%d", j);

```

 If $i \geq 2$, then the value of j , will be printed only if
 (a) i is prime (b) j does not divide i
 (c) j is odd (d) i is not prime
238. Choose the correct statements.
 (a) 'x' is same as "x".
 (b) Length of the string "x" is two.
 (c) Unless otherwise specified, the first name in an enum has the value 1.
 (d) None of the above.
239. Choose the correct statements.
 (a) enum is a data type.
 (b) In the same enumeration, values must be distinct.
 (c) enum feature is an alternative to the define feature.
 (d) None of the above.
240. The declaration

```

enum cities{bethlehem, jericho, nazareth = 1, jerusalem}

```

 assigns the value 1 to
 (a) bethlehem (b) nazareth
 (c) bethlehem and nazareth (d) jericho and nazareth
241. Choose the correct statements.
 (a) enum variables can be assigned new values.
 (b) enum variables can be compared.
 (c) Enumeration feature does not increase the power of C.
 (d) Use of enumeration enhances the logical clarity of a program.

- *29. The SQL statement

```

SELECT SUBSTR('abcdefghij', INSTR('123321234', '2', 3, 2), 2) FROM DUAL;

```

 prints
 (a) gh (b) 23 (c) bc (d) ab
- *30. From the following combinations of wildcard characters, choose those that are equivalent.
 (a) % (b) _% (c) %_ (d) _ _
- *31. The SQL statement

```

SELECT ROUND(45.926, -1) FROM DUAL;

```

 (a) is illegal (b) prints garbage (c) prints 045.926 (d) prints 50
32. Which of the following must be enclosed in double quotes?
 (a) Dates (b) Column Alias (c) Strings (d) All of these
- *33. If the SQL statement

```

SELECT NEXT_DAY('01-SEP-95', 'FRIDAY') FROM DUAL;

```

 prints
 08-SEP-95
 what will the SQL statement

```

SELECT NEXT_DAY('01-SEP-95', 'SATURDAY') FROM DUAL;

```

 print?
 (a) 09-SEP-95 (b) 02-SEP-95 (c) 05-SEP-95 (d) 06-SEP-95
- *34. The SELECT statement

```

SELECT 'Hi' FROM DUAL WHERE 1 != NULL;

```

 outputs
 (a) TRUE (b) Hi (c) FALSE (d) nothing
- *35. In SQL, $10/\text{NULL}$ will evaluate to
 (a) FALSE (b) -1 (c) NULL (d) 10
36. Almost all the DATE functions return a value of data type DATE, except
 (a) MONTHS_BETWEEN (b) ROUND
 (c) NEXT_DAY (d) TRUNC
37. The SELECT statement

```

SELECT LOWER('AbCd'), UPPER('AbCd'), INITCAP('AbCd eFgh') FROM DUAL;

```

 will print
 (a) abcd ABCD Abcd eFgh (b) abcd ABCD ABCD EFGH
 (c) abcd ABCD abcd eFgh (d) abcd ABCD aBCD eFGH
- *38. The SQL statement

```

SELECT TRUNC(45.926, -1) FROM DUAL;

```

 (a) is illegal (b) 5 (c) prints 45.9 (d) prints 40
39. The SQL statement

```

SELECT SUBSTR('123456789', INSTR('abcabcabc', 'b', 4)) FROM DUAL;

```

 prints
 (a) 2345 (b) 6789 (c) 56789 (d) 89

19. You are executing a SELECT statement. In the display, each row that is displayed spans more than a line and you see a line after a set of 5 records. You can fix this problem by using the
- SET LINESIZE command
 - SET PAGESIZE command
 - SET LINESIZE and SET PAGESIZE commands
 - SET SCREENWIDTH command
20. Which command is used to get input from the user?
- GET
 - ACCEPT
 - READ
 - CIN
21. Which of the following remarks about SQL*Plus are correct?
- It is a PL/SQL development tool
 - It works in character mode
 - It is an integral part of the standard Oracle installation
 - It does not have a PL/SQL engine
22. To interactively assign a value to a variable, precede the variable name with
- :
 -
 - getVal
 - &
23. Which of the following SQL*Plus commands can be used to see the compilation errors in a PL/SQL code?
- TRACE
 - SHOW ERRORS
 - PROFILE
 - DEBUG

Questions 24 to 109 are from SQL.

24. NOT BETWEEN 10 AND 20
- displays NULL values
 - does not display NULL values
 - may display NULL values
 - none of these
- *25. The SQL statement
SELECT SUBSTR('123456789', INSTR('abcabcabc', 'b'), 4) FROM DUAL ;
prints
- 6789
 - 2345
 - 1234
 - 456789
- *26. The SELECT statement
SELECT 'Hi' FROM DUAL WHERE 1 = NULL;
outputs
- Hi
 - FALSE
 - TRUE
 - nothing
27. Which of the following group functions ignore NULL values?
- MAX
 - COUNT
 - SUM
 - COUNT(*)
- *28. Table Employee has 10 records. It has a non-NULL SALARY column which is also UNIQUE. The SQL statement
SELECT COUNT(*) FROM EMPLOYEE WHERE SALARY > ANY (SELECT SALARY FROM EMPLOYEE);
prints
- 10
 - 9
 - 5
 - 0

- *242. Consider the following statement.

```
# define hypotenuse(a, b) sqrt(a * a + b * b);
```

```
The macro-call hypotenuse(a + 2, b + 3);
```

- finds the hypotenuse of a triangle with sides $a + 2$ and $b + 3$
 - finds the square root of $(a + 2)^2 + (b + 3)^2$
 - is invalid
 - finds the square root of $3*a + 4*b + 5$
243. For the previous question, which of the following macro-calls, will find the hypotenuse of a right angled triangle with sides $a + 1$ and $b + 1$?
- hypotenuse (a+1,b+1)
 - hypotenuse (++a, ++b)
 - hypotenuse (a++,b++)
 - none of the above
- *244. If a variable can take only integral values from 0 to n , where n is a constant integer, then the variable can be represented as a bit-field whose width is the integral part of (the log in the answers are to the base 2)
- $\log(n) + 1$
 - $\log(n - 1) + 1$
 - $\log(n + 1) + 1$
 - none of the above
245. The statement `printf("%d", 10?0?5:11:12);`
prints
- 10
 - 0
 - 12
 - 11
246. The statement `printf("%d", (a++));` prints
- the current value of a
 - the value of $a + 1$
 - an error message
 - garbage
247. The statement `printf("%d", ++5);` prints
- 5
 - 6
 - an error message
 - garbage
248. The statement `printf("%d", sizeof(""));` prints
- an error message
 - 0
 - garbage
 - 1
249. If p is a pointer to an integer and t is a pointer to a character then `sizeof(p)` will be
- same as that of `sizeof(t)`
 - greater than that of `sizeof(t)`
 - less than that of `sizeof(t)`
 - none of the above
250. Which of the following comments about arrays and pointers is/are not true?
- Both are exactly same
 - Array is a constant pointer
 - Pointer is an one-dimensional array
 - Pointer is a dynamic array
251. `lint` is
- a C compiler
 - an inter-active debugger
 - a C interpreter
 - a tool for analyzing a C program
252. `cb` is a
- C code beautifying tool
 - C interpreter
 - C compiler
 - none of the above

253. It is not advisable to use macros instead of functions because
- it increases the code size
 - no type checking will be done
 - recursion is not possible
 - pointers cannot be used with macro identifiers
254. In a C program constant is defined
- before main
 - after main
 - anywhere, but starting on a new line
 - none of the above
255. The rule for implicit type conversion is
- int < unsigned < float < double
 - unsigned < int < float < double
 - int < unsigned < double < float
 - unsigned < int < double < float
256. Which of the following is/are syntactically correct?
- for();
 - for(,);
 - for(,);
 - for(;;);
257. Use of macro instead of function is recommended
- when one wants to reduce the execution time
 - when there is a loop with a function call inside
 - when a function is called in many places in a program
 - in all the above cases
258. The ascending order of precedence of the bit-wise operators &, ^, | is
- &, ^, |
 - ^, &, |
 - |, ^, &
 - &, |, ^
- *259. Consider the declaration
- ```
char street[10] = "abcdefghi";
```
- Choose the correct remark(s).
- &street and street will have different values
  - &street is meaningless
  - &street+1 and street+1 will have the same values
  - None of the above
- \*260. Consider the following program fragment.
- ```
d = 0;
for(i = 1; i < 31; ++i)
  for(j = 1; j < 31; ++j)
    for(k = 1; k < 31; ++k)
      if(((i + j + k) % 3) == 0)
        d = d+1;
printf("%d",d);
```
- The output will be
- 9000
 - 27000
 - 3000
 - none of the above
6. A script file that is executed by SQL*Plus cannot contain
- SQL*Plus commands
 - SQL statements
 - PL/SQL block
 - none of these
7. Script files can be executed by the
- START command
 - STA command
 - @ command
 - EXECUTE command
8. To change the format of the date returned by SYSDATE, use the command
- ALTER SESSION RESET DATE
 - ALTER SESSION CHANGE DATE
 - ALTER SESSION SET SYSDATE
 - ALTER SESSION SET NLS_DATE_FORMAT
9. Which of the following methods cannot be used to specify a comment in SQL*Plus scripts?
- - REMARK
 - /*...*/
 - None of these
10. The DUAL table has
- One row with many columns
 - One column with many rows
 - One row and one column
 - Many rows and many columns
11. The DESCRIBE command if used on a table, will not display information about
- Primary key
 - Default Values
 - Indexes
 - Triggers
12. The ALL Data Dictionary view lets you access any object
- owned by you
 - for which you have access rights
 - in the database
 - none of these
13. A PL/SQL block can return data to SQL*Plus through
- bind variables
 - substitution variables
 - local variables
 - none of these
14. Which of the following is not a type of data dictionary view?
- USER
 - ALL
 - DBA
 - SYS
15. Which of the following information will be displayed when you use the DESCRIBE command on functions?
- Data type of the return value
 - Data type of the parameters
 - Mode of the parameters
 - Default value of the parameters
16. The owner of the DUAL table is
- SYS
 - SUPERUSER
 - SCOTT
 - MANAGER
17. Which of the following data dictionary view is used by the DESCRIBE command to extract information about the columns?
- ALL_TABLES
 - ALL_COLUMNS
 - ALL_COLS
 - ALL_TAB_COLUMNS
18. SGA stands for
- Show Global Area
 - Start Global Area
 - System Global Area
 - Shut Global Area

Chapter 16

SQL*PLUS, SQL, PL/SQL, Forms and Reports

Questions 1 to 23 are from SQL*Plus.

- Which of the following activities are you allowed to do after executing the DISCONNECT command?
 - Reconnect
 - Exit the SQL*Plus session
 - Execute certain SQL*Plus commands
 - None of these
- What does the / command do?
 - Does nothing
 - Prints the character /
 - Re-executes the non SQL*Plus command that was most recently executed.
 - Re-executes the most recently executed command
- What command should you try if DBMS_OUTPUT.PUT_LINE is not doing what it is supposed to do?
 - SET ECHO ON
 - SET TERMOUT ON
 - SET DISPLAY ON
 - SET SERVEROUTPUT ON
- SQL*Plus will know you are typing a PL/SQL block when it encounters the keyword
 - PL/SQL
 - BEGIN
 - EXCEPTION
 - DECLARE
- Which of the following is buffered by SQL*Plus?
 - SQL statements
 - SQL*Plus commands
 - PL/SQL block
 - None of these

- *261. The number of additions performed by the above program fragment is
- 27000
 - 27000×3
 - $9000 + 3 \times 27000$
 - $9930 + 27000 \times 3$

Answers

- | | | | |
|-----------------|----------------|-----------------|----------------|
| 1. c | 2. c, d | 3. a | 4. c |
| 5. a, b | 6. d | 7. c | 8. d |
| 9. a | 10. a | 11. b | 12. b |
| 13. d | 14. b | 15. b | 16. b |
| 17. a | 18. c, d | 19. a, b | 20. b, c |
| 21. c | 22. a, b, c, d | 23. c | 24. c |
| 25. a | 26. a, b, c, d | 27. c | 28. a, b, c, d |
| 29. a, b, c | 30. a, b, c | 31. d | 32. b, d |
| 33. a, b, c, d | 34. a, b, d | 35. a, b, c | 36. c |
| 37. a, b, c | 38. a, b, d | 39. c | 40. d |
| 41. d | 42. a, b, c, d | 43. a, c | 44. c |
| 45. b | 46. c | 47. c | 48. d |
| 49. a | 50. a, b, c | 51. c | 52. c |
| 53. b, c, d | 54. d | 55. b | 56. b |
| 57. a | 58. a | 59. d | 60. a |
| 61. b | 62. c | 63. d | 64. a |
| 65. d | 66. a | 67. c | 68. a |
| 69. d | 70. c | 71. a | 72. b |
| 73. b, c, d | 74. a | 75. a, b, c, d | 76. a, b, c, d |
| 77. a, c | 78. d | 79. c | 80. a, b |
| 81. a | 82. d | 83. a, b, c | 84. b, c, d |
| 85. a | 86. d | 87. b | 88. a |
| 89. d | 90. a, b | 91. a, b, c | 92. d |
| 93. b | 94. c | 95. a | 96. c |
| 97. c | 98. d | 99. a | 100. d |
| 101. d | 102. c | 103. a, b, c, d | 104. b |
| 105. d | 106. a, d | 107. c | 108. c |
| 109. b | 110. d | 111. c | 112. a, b |
| 113. c | 114. a, b | 115. b, d | 116. a |
| 117. a, b, c | 118. a, b, c | 119. b | 120. c |
| 121. a, b, c, d | 122. a, b, c | 123. b, c | 124. a, c, d |
| 125. c | 126. a, b | 127. a | 128. c |
| 129. c | 130. a, b | 131. a | 132. b |
| 133. a | 134. d | 135. c | 136. a |
| 137. b | 138. d | 139. d | 140. d |
| 141. a | 142. c | 143. b | 144. b |
| 145. a | 146. b | 147. a | 148. a, b |
| 149. a, b, d | 150. a, c, d | 151. b, c | 152. a, c |
| 153. c | 154. c | 155. a, b, c | 156. a |
| 157. a, b, c | 158. c | 159. d | 160. c |

- | | | | |
|-----------------|-----------------|--------------|-----------------|
| 161. a | 162. c | 163. d | 164. a, b |
| 165. c | 166. b | 167. a, b, c | 168. a, b |
| 169. a, b | 170. c | 171. a | 172. c |
| 173. b, c | 174. a, b, d | 175. a, c, d | 176. a |
| 177. a, b | 178. c | 179. b | 180. a |
| 181. d | 182. a | 183. a | 184. c |
| 185. c | 186. a, b, c | 187. d | 188. a, b, c, d |
| 189. a | 190. a, b | 191. a, b, c | 192. b, c, d |
| 193. b, d | 194. a, b | 195. b, c | 196. a, c, d |
| 197. c | 198. a, b, c | 199. a, c | 200. a, b, c |
| 201. a, c | 202. a | 203. d | 204. c |
| 205. a, b | 206. c | 207. c | 208. b |
| 209. b | 210. d | 211. c | 212. a, b, c |
| 213. d | 214. a, b, c, d | 215. c | 216. a, b, c, d |
| 217. a, d | 218. a | 219. a | 220. c |
| 221. d | 222. d | 223. a | 224. a |
| 225. c | 226. d | 227. b | 228. a, b, d |
| 229. a | 230. a, b, c | 231. a, b, d | 232. d |
| 233. a | 234. d | 235. c | 236. a |
| 237. d | 238. d | 239. a, c | 240. d |
| 241. a, b, c, d | 242. d | 243. d | 244. a |
| 245. d | 246. a | 247. c | 248. d |
| 249. a | 250. a, b, c, d | 251. d | 252. a |
| 253. a, b, c, d | 254. c | 255. a | 256. d |
| 257. a, b | 258. c | 259. d | 260. a |
| 261. d | | | |

Explanations

6. Without any temporary variable, one can swap two given variables. Refer Qn. 7.
11. In signed magnitude form, one bit is dedicated to store the `sign`. (e.g., 1 for negative and 0, otherwise). Only the remaining 15 bits are available to store the magnitude. Hence the answer.
12. Any function (including `main()`), returns a value to the calling environment. In the case of `printf`, it is the number of characters it printed. So, the output will be `tim3` (since it printed the three characters `a`, `b`, `c`).
13. Refer Qn. 12.
The `scanf` function returns the number of successful matches. i.e., 3 in this case.
14. The input is actually `a\nb`. Since we are reading only two characters, only `a` and `\n` will be read and printed.
23. If $y = 11$, the expression $3 * (y - 8) / 9$ becomes $3 * 3 / 9$, which evaluates to 1. But the expression $(y - 8) / 9 * 3$ becomes $3 / 9 * 3$, which evaluates to 0 (since $3/9$ is 0).
27. Strictly speaking, it will have a garbage value. Some implementations initialize to 0 on declaration.

47. The reliability of a program be 0.8. The reliability of an equivalent program (ie., another program that serves the same purpose) is 0.9. The probability that both the programs give the wrong result for the same input is
(a) 0.72 (b) 1.7 (c) 0.1 (d) 0.02
48. The program volume of a source code that has 10 operators including 6 unique operators, and 6 operands including 2 unique operands is
(a) 48 (b) 120 (c) 720 (d) insufficient data
- *49. To increase reliability, fault tolerance is included in the system in the form of multiple modules. If the problem can be solved by 5 different modules, each with probability of success 0.7, the probability that it can be solved even if 4 modules fail is approximately
(a) 0.3 (b) 0.03 (c) 0.49 (d) 0.05
50. In object-oriented design of software, objects have
(a) attributes and name only (b) operations and name only
(c) attributes, name and operations (d) none of the above

Answers

- | | | | | |
|-------|-------------|-------------|-------|-------|
| 1. c | 2. a, b, c | 3. a, b, c | 4. c | 5. c |
| 6. d | 7. c | 8. b | 9. c | 10. d |
| 11. d | 12. a | 13. a | 14. a | 15. a |
| 16. d | 17. d | 18. a, b, c | 19. a | 20. d |
| 21. a | 22. a, b, c | 23. b | 24. a | 25. b |
| 26. c | 27. a, b, c | 28. b | 29. c | 30. d |
| 31. b | 32. a | 33. d | 34. c | 35. a |
| 36. a | 37. a, b, c | 38. c | 39. d | 40. c |
| 41. b | 42. a | 43. b | 44. b | 45. c |
| 46. d | 47. d | 48. a | 49. b | 50. c |

Explanations

7. Writing the whole program in FORTRAN takes 100 man-days. Rewriting the 1% code takes 4 man-days. Altogether 104 man-days. If it is completed in 13 days, $104/13 = 8$ men should be involved.
8. The first case takes $99 + 10 = 109$ man-days. The second case takes $100 + 4 = 104$ man-days. The required percentage is $(109 - 104) \times 100/100 = 5$.
9. Let the first case takes 100 units of time to execute. The second case will take $99 + (1/5)$ units of time, as coding the 1% in assembly language will take $1/5$ units of time. Hence the required percentage is $0.8 \times 100/100 = 0.8$.
10. In both the cases, the final program will have the same 99% of the code in FORTRAN and the remaining 1% in assembly language. Hence the execution time will remain the same.
11. The first case has a measure of $((3 \times 109) + 2 \times (99 + 1/5))/5$ and the second $((3 \times 104) + 2 \times (99 + 1/5))/5$. Lower the measure, the more preferable it is.

37. Which of the following software engineering concept does Ada language support?
 (a) Abstraction (b) Generic
 (c) Information hiding (d) None of the above
- *38. In unit testing of a module, it is found that for a set of test data, at the maximum 90% of the code alone were tested with the probability of success 0.9. The reliability of the module is
 (a) greater than 0.9 (b) equal to 0.9
 (c) at most 0.81 (d) at least 1/0.81
39. Which of the following testing methods is normally used as the acceptance test for a software system?
 (a) Regression testing (b) Integration testing
 (c) Unit testing (d) Functional testing
40. A computer program can often be a very satisfactory of a physical system such as road traffic conditions.
 (a) solution (b) replacement (c) simulation (d) model
41. `for(i = 0, s = 0; i < n; i++) s += a [i];`
 The symbolic execution with $n = 3$ at $i = 2$, s is
 (a) $a_0 + a_1 + a_2 + a_3$ (b) $a_0 + a_1 + a_2$
 (c) $a_0 + a_1$ (d) $a_0 + a_1 + a_3$
- *42. On an average, the programmer months is given by $3.6 \times (\text{KDSI})^{1.2}$. If so, a project requiring one thousand source instructions will require
 (a) 3.6 PM (b) 0.36 PM (c) 0.0036 PM (d) 7.23 PM
43. Software testing techniques are most effective if applied immediately after
 (a) requirement specification (b) design
 (c) coding (d) integration
44. Consider the following code for finding the factorial of a given positive integer.

```
IFACT = 1
DO 100 I = 2, N, 2
100 IFACT = IFACT * I * (I-1)
```

 For which values of N , the above FORTRAN code doesn't work?
 (a) N is even (b) N is odd
 (c) N is perfect number (d) $N \bmod 3 = 0$
45. For the above code, using symbolic execution, after the iteration with $N = 5$, $IFACT$ is
 (a) $1 * 1 * 2 * 3 * 4 * 5$ (b) $1 * 2 * 3 * 4 * 5$
 (c) $1 * 1 * 2 * 3 * 4$ (d) $1 * 2 * 3 * 4$
46. Which of the following is not an assertion?
 (a) P is true, P and Q are true and K or not (Q) is true implies K is true.
 (b) P is true, P and Q are true and K or not (Q) is true implies K is true.
 (c) P is true, P and Q are false and K or Q is true implies K is true.
 (d) P is true, P and Q are true and K or not (K) is true implies K is true.

39. $y *= 2$ means $y = y * 2$ i.e., $y = 4$, in this problem. So, the expression is equivalent to $x = 4 + 4$, which is 8. So, 8 will be printed. However, the order in which the operands are evaluated is implementation-dependent. If the right operand is evaluated first, the result will be 6. Don't take things for granted.
40. Most of the compilers give `4 4` as the output. This is because most of the compilers use stacks to evaluate the arguments. If so, the first argument `n++` will be pushed before the `++n` is pushed. This implies that `++n` will be evaluated before `n++` is evaluated. However, the order of printing will be in accordance with the order the variables are listed in the `printf` statement.
44. $5 - 2 - 3 * 5 - 2$ will yield 18, if it is treated as $(5 - (2 - 3)) * (5 - 2)$. i.e., if $-$ has precedence over $*$ and if it associates from the right.
46. 263 in binary form is 100000111. If one tries to print an integer as a character, only the last 8 bits will be considered—the rest chopped off. So, in this case the ASCII value of 00000111 (i.e., decimal 7) will be printed. Look in the ASCII table. It is ringing a bell!
48. $9/5$ yields integer 1. Printing 1 as a floating point number prints garbage.
50. `IF` is not a keyword, because it is in upper case.
51. In the computer I used to execute this program, the output was 4294967293. That's because in my system,
`sizeof(int)` is 4 bytes (32 bits), and negative numbers are represented in 2's complement form. This means -4 will be represented as 11111111 11111111 11111111 11111100 (i.e. 30 one's followed by 2 zeroes). Note that this number is $2^{32} - 1 - 3$. Before j gets added to i , it will be converted to an unsigned integer. So, $i+j$ is essentially adding 1 to $2^{32} - 1 - 3$, which gives 4294967293.
52. Let `sizeof(int) = 1`. So, -4 will be stored as 11111100. Since we are adding unsigned and signed integers, the signed gets converted to unsigned. So, $i + j$ will become 11111101. We are trying to print this as an unsigned integer. So, what is printed will be $2^8 - 1 - 2$. So, $\log(x + 3) = 8$ (i.e., $8 * \text{sizeof(int)}$).
54. ' i ' is initialized to 3, and incremented by 3. When i is 15, control will go out of the loop. So 15 will be printed. (The empty semi-colon immediately following the '`for`' statement, means the body of the `for` loop is empty.)
55. The use of `continue` statement forces the execution to skip the remainder of the current pass over the loop and initiates the next. If ' i ' is 3, `printf` statement will be skipped. Hence the answer is b.
58. $k = -7$. So, if ' k ' is used as a Boolean variable, it will be treated as a true condition. So, `!k` will be false i.e., 0. So, $0 < ? !k$ is actually $0 < 0$, which is false. So, 0 will be printed.
66. `putchar(105)` will print the ASCII equivalent of 105 i.e., ' i '. The `printf` statement prints the current value of i , i.e. 5 and then decrements it. So, `h4` will be printed in the next pass. This continues until ' i ' becomes 0, at which point the loop gets terminated.
67. Since $x > 7$ is false, the ternary operator `?:` returns "`%c`". So, `printf("%c", i)` will be executed. So, the ASCII character corresponding to 107, i.e., ' k ' will be printed.
68. Refer Qn. 67.

69. `printf("az")` prints `az` and returns a value 2 (since it printed two characters). So, the condition results in the printing of `az2`. Since it always returns 2, it is an infinite loop. The output will be `az2byaz2by. . .`
82. Refer Qn. 69
Here the `else` clause will be executed. Since `2 < 0` is false, `four4` will be printed.
83. The `else` clause has no brackets i.e., `{` and `}`. This means the `else` clause is made up of only one statement. So, `printf("a <= b");` will be executed anyway, i.e. if `a>b` or `a<=b`. Hence the answer.
85. The condition is `putchar(0)`. This returns a value 0 which is a false condition. So, the loop will not be executed even once.
90. The expression should be evaluatable at compile time and it should evaluate to a positive integer.
92. If it is coming within a function, the storage class will be taken to be automatic, otherwise external.
98. `a[2]` will be converted to `*(a + 2)`.
`*(a + 2)` can as well be written as `*(2 + a)`.
`*(2 + a)` is nothing but `2[a]`. So, `a[2]` is essentially same as `2[a]`, which is same as `*(2 + a)`. So, it prints `9 + 9 = 18`. Some of the modern compilers don't accept `2[a]`.
105. `*a` points to the string `"abcd"`. `**a` is the first character of `"abcd"`, which is the character `'a'`.
106. C does no array bound checking. Because of this, one can access fifth element of an array that is declared to be of lesser size.
112. C supports 1-dimensional arrays only. But, the array element can be an array by itself. Using this, one can simulate multi-dimensional arrays. Though at the user level, we use 2-dimensional arrays, the compiler interprets this as a 1-dimensional array, each of whose element is a 1-dimensional array. As a matter of fact, a declaration like `char x[3][4]`, will be interpreted as a 1-dimensional array of size 3 (rather than 4)—each element being a character array of length 4.
113. As an implication of this, the output of the following program
- ```
main()
{int i = 5;
 printf("%d %d", ++i, i++);
}
```
- is unpredictable.
115. Consider the following program
- ```
main()
{ int i = 5;
  { int i = 6;
    printf ("%d", i);
  }
  printf ("%d", i);
}
```

- *16. Let M be a node that represents a `if-then-else` node in a Program Graph. Let the number of paths from its `if` part to the end node is y , and from the `else` part to the end node is z . If the number of paths from the start node to the node M is x , then the total number of paths through M is
- (a) $xy + z$ (b) $xz + y$ (c) $x + y + z$ (d) $x(y + z)$
17. If X is a case statement in a Program Graph with n cases instead of an `if-then-else` statement in the previous question with each case leading to only one path to end node, total number of paths through X is
- (a) $x + n$ (b) x^n (c) $x \log(n)$ (d) xn
18. Structured programming codes include
- (a) sequencing (b) alteration
(c) iteration (d) multiple exit from loops
19. Which of the following is a desirable property of a module?
- (a) Independency (b) Low cohesiveness (c) High coupling (d) Multi functional
20. Which of the following types of maintenance takes the maximum chunk of the total maintenance effort in a typical life cycle of a software product?
- (a) Adaptive maintenance (b) Corrective maintenance
(c) Preventive maintenance (d) Perfective maintenance
21. An important aspect in coding is
- (a) readability (b) productivity
(c) to use as small a memory space as possible (d) brevity
22. One way to improve readability in coding is to
- (a) avoid goto statements
(b) name variables and functions according to their use
(c) modularize the program
(d) none of the above
23. The data flow model of an application mainly shows
- (a) the underlying data and the relationship among them
(b) processing requirements and the flow of data
(c) decision and control information
(d) communication network structure
24. According to Brooks, if n is the number of programmers in a project team then the number of communication paths is
- (a) $n(n-1) / 2$ (b) $n \log n$ (c) n (d) $n(n+1) / 2$
25. The extent to which the software can continue to operate correctly despite the introduction of invalid input is called as
- (a) reliability (b) robustness (c) fault-tolerance (d) portability
26. If the number of conditions in a decision table is n , the maximum number of rules (columns) possible is
- (a) n (b) $2n$ (c) 2^n (d) $\log_2 n$

- (c) data, architectural and interface designs only
 (d) data, architectural, interface and procedural designs

The next 5 questions are based on the information furnished below.

In a particular program, it is found that 1% of the code accounts for 50% of the execution time. To code the program in FORTRAN, it takes 100 man-days. Coding in assembly language is 10 times harder than coding in FORTRAN, but runs 5 times faster. Converting an existing FORTRAN program to an assembly language program is 4 times harder.

- *7. To completely write the program in FORTRAN and rewrite the 1% code in assembly language, if a project team needs 13 days, the team consists of
 (a) 13 programmers (b) 10 programmers
 (c) 8 programmers (d) 100/13 programmers
- *8. If 99% of the program is written in FORTRAN and the remaining 1% in assembly language, the percentage increase in the programming time compared to writing the entire program in FORTRAN and rewriting the 1% in assembly language is
 (a) 10 (b) 5 (c) 13 (d) 8
- *9. If the entire program is written in FORTRAN, the percentage increase in the execution time, compared to writing the entire program in FORTRAN and rewriting the 1% in assembly language is
 (a) 0.9 (b) 8 (c) 0.8 (d) 9
- *10. If 99% of the program is written in FORTRAN and the remaining 1% in assembly language, the percentage increase in the execution time, compared to writing the entire program in FORTRAN and rewriting the 1% in assembly language is
 (a) 0.9 (b) 1 (c) 0.1 (d) 0
- *11. If a weightage of 3 is given to the programmers effort and a weightage of 2 is given to the execution time, then coding 99% in FORTRAN and the 1% in assembly language performs better than coding in FORTRAN completely and rewriting the 1% in assembly language by a factor of about
 (a) 1.5 (b) 1.2 (c) 1.1 (d) it does not perform better
12. Data structure suitable for the application is discussed in
 (a) data design (b) architectural design
 (c) procedural design (d) interface design
13. Design phase will usually be
 (a) top-down (b) bottom-up (c) random (d) centre fringing
14. Assertions are conditions which are true at the point of execution
 (a) always (b) sometimes (c) many times (d) no time
15. Assuming the existence of a start and end nodes for a program graph, the total number of paths is equivalent to the set of test data required to test the software.
 (a) minimum (b) maximum (c) optimum (d) supremum

Its output clearly shows, local variables can have the same name and their scope may be confined to a single statement.

116. Which means a function will be manipulating a copy of the local variable, passed as argument. So, any change will be local and hence will not be reflected in the calling routine (Refer Qn. 128)
119. This involves recursion - main() calling itself. So, it keeps on printing tim
120. Since Madam is the required output, the function first(), should print 'a', call the function second() that prints the 'd' and print 'a' again. Hence c is the correct answer.
128. Refer Qn. 116. change(a), prints 5 but the value of 'a' in main() is still 4. So, main() will print 4.
131. This will not compile successfully. The scope of the variable 'j' is the single printf statement that follows it. So, the last statement that involves 'j' will complain about the undeclared identifier 'j'.
132. By default x will be initialized to 0. Since its storage class is static, it preserves its exit value (and forbids reinitialization on re-entry). So, 123 will be printed.
137. The compiler will tokenize a+++b as a, ++, +, b. So, a+++b is equivalent to a+++ b, which evaluates to 7.
138. Refer Qn. 137. a+++++b will be tokenized to a, ++, ++, +, b. The compiler (parser), while grouping the tokens to expression, finds the second ++, applied to a++, an integer. Since ++ and ++b operator needs address (i.e., L-value), it will display the error message - Invalid lvalue in increment. So, to add a++ and ++b, use parenthesis or blanks to tokenize the way you intended.
139. return always terminates the function that executed it. main() being a function, will be terminated when it executes the return statement. The return value will be returned to the calling environment, which is the operating system in this case.
140. argv[0] is a pointer to the executable code file name. So, puts(argv[0]); prints it.
142. Like array name, name of a function is a pointer to it.
143. The function abc can be invoked as abc() or (*abc)(). Both are two different ways of doing the same thing.
144. The declaration means, ptr is a pointer, pointing to a one dimensional character array of size 4. It is assigned the address wer. So, ptr and ptr + 1 will differ by 4 bytes.
153. Using a pointer variable, without initializing it, will be disastrous, as it will have a garbage value.
159. **c = 5, essentially means a = 5, as can be seen with the following pictorial representation of the given declarations.

Address	Value	Name
100	4	a
120	100	b
135	120	c

160. The statement is same as `(int *)a`. So, the value of 'a' i.e., 5 is converted into a pointer to integer data type, because of the casting assigned to a.
163. Pointers are actually addresses. Though the address will be an integer, it is not of integer data type. Both have different set of operations defined on them, e.g., integer addition is different from pointer addition.
178. The `first` declaration means, `first` is a function (returning a character), whose only argument is, a pointer to a function that takes a character and `float` as arguments and returns an integer. The name of a function can be used as the starting address of the function (i.e., a pointer to it). So, option c is correct.
181. Since 'a' is an integer and 'b' is a pointer, they can't be multiplied.
182. `a**b` will be semantically interpreted as `a * (*b)`. Since 'a' and `*b` are integers, they can be multiplied.
203. For each 8 bits one can save 1 bit. So percentage reduction will be $1/8 * 100$ i.e., 12.5%.
208. If there is no space to accommodate the entire bit-field, it will be completely shifted to the next word.
210. A bit-field need not be named.
211. A field of width 0, forces the next bit-field to the next word. So, three words are necessary.
212. Bit-fields are meant to reduce the memory needed. So, this is indeed a misuse of bit-fields. (Refer Qn. 211)
217. Use of functions involves storing the current contents and branching to its starting address. These things add to the execution time. On the other hand, macro substitution increases the code size. This is of serious concern, if the macro is used in many places.
221. First form the truth table of the exclusive OR operation. If both the switches are off i.e., 0, 0 then the light will be off i.e., 0. So, 0, 0 yields 0. If you switch on either of the two switches i.e., 0 1 or 1 0, the light will be on. So, 0 1 yields 1 (so does 1 0). Now, if you switch on the other one, which is currently off, it will be 1 1. This should yield a 0. Compare these results with the truth table of XOR.
222. The left shift operator `<<`, pushes out the most significant (left-most) bit. If it happens to be a 1, `a << 1`, will not be same as multiplying a by 2.
224. Refer Qn. 222. If the most significant bit is to be zero, the maximum number that can be stored in 7 bits is 127.
226. The sum (or bit-wise OR) of a number and its 1's complement will be all 1's. How many 1's depends on how many bits are needed to represent the number. If the sum is $2^{20} - 1$, then the `sizeof(int)` in bits must be 20.
233. The binary representation of odd numbers will have a 1 as the least significant digit. So, an odd number ANDed with 1, produces a 1. Even number end with 0. So, an even number ANDed with 1, produces a 0. This `for` loop generates even and odd numbers alternatively. So, it prints alternate 0's and 1's.
238. `"x"` is made up of two characters 'x' and '\0'. Anyway its length is 1. By default, the first name in an `enum` will be assigned the value 0.
240. The listed places will be assigned the values 0, 1, 1, 2 respectively.

Chapter 15

Software Engineering

- Software engineering primarily aims on developing
 - reliable software
 - cost effective software
 - reliable and cost effective software
 - none of the above
- A good specification should be
 - unambiguous
 - distinctly specific
 - functional
 - none of the above
- Which of the following is a tool in design phase?
 - Abstraction
 - Refinement
 - Information hiding
 - None of the above
- Information hiding is to hide from user, details
 - that are relevant to him
 - that are not relevant to him
 - that may be maliciously handled by him
 - that are confidential
- Which of the following comments about object oriented design of software, is not true?
 - Objects inherit the properties of the class
 - Classes are defined based on the attributes of objects
 - An object can belong to two classes
 - Classes are always different
- Design phase includes
 - data, architectural and procedural designs only
 - architectural, procedural and interface designs only

41. d 42. a, b, d 43. b 44. a 45. c
 46. c 47. c 48. b 49. b 50. b
 51. d 52. d 53. a 54. d 55. c
 56. d 57. b 58. a 59. b 60. d
 51. a

Explanations

9. In bipolar code the signal varies among three levels. In non-return to zero code the signal remains the same throughout the bit cell. In unipolar code, there will be no signal either below zero or above zero. In Manchester code, the signal level will not vary in the middle and is unipolar.
16. Start and stop bits are not needed in synchronous transfer of data. So, it is $2400/8 = 300$.
22. Bit stuffing is required when there is a flag of bits to represent one of the incidents, like start of frame, end of frame, etc.,. If the same flag of bits appear in the data stream, a zero can be inserted. The receiver deletes this zero from the data stream.
28. As all lines are full-duplex and there are no self connections, only the cross points above the diagonal are needed. Hence formula for the number of cross points needed is $n(n-1)/2$
29. Since there are six 1200 bps terminals, $6 \times 1200 + n \times 300 = 9600$. Solving, $n = 8$.
33. Maximum data rate = $2H \log_2 V$ bps, where H is the bandwidth, V is the discrete levels. Here H is 3 kHz and V is 2.
34. Maximum number of the bps = $H \log_2 (1 + \text{SNR})$.
35. In time division switches $2nT = 1$ frame period, where T is the memory access time.
46. The Huffman code for A will have 2 digits, B –3 digits, C –3 digits, D –2 digits and E –2 digits. This can be obtained by constructing the binary tree corresponding to the given probabilities.
47. Refer to the explanation of the previous question.
48. Average code length is the sum of product of the length and probability of the occurrence of the symbols. Here it is, $2 \times 0.3 + 3 \times 0.15 + 3 \times 0.1 + 2 \times 0.25 + 2 \times 0.2 = 2.25$.

242. The macro call will be expanded as

```
sqrt(a + 2 * a + 2 + b + 3 * b + 3).
```

i.e., $\text{sqrt}(3 * a + 4 * b + 5)$. Hence the answer.

244. Let $n = 7$. It needs actually a 3 bit-field. But $\log(n + 1) + 1$ will be $\log(8)+1$, i.e., 4, which is wrong. If $n = 8$, 4 bits are needed. But, $\log(n - 1) + 1$ will be $\log(7) + 1$, which will have an integral part of 3. $\log(n) + 1$ will yield the correct result in both the cases.

259. `&street` and `street` will have the values which is the starting address of the street array. However, `street` is a pointer to the first character whereas `&street` is a pointer to the entire array. The incremented values of `street` and `&street` reflects this difference.

260. $a+b+c\%3$ will be 0 if $a+b+c$ is a multiple of 3. This will happen in one of the following ways. All three – a , b , and c are multiples of 3. This can only happen if a , b , and c take one of the 10 values, $-3, 6, 9, \dots, 30$, independent of one another. So, there are $10 \times 10 \times 10 = 1000$ ways this can happen. Another possibility is that a , b , and c all leave a remainder 1 so that $a+b+c$ is evenly divisible by 3. Considering all the different possibilities and adding, we get 9000. That will be the integer that gets printed.

261. Refer Qn. 260.

The result can be analytically reasoned out. It can also be programmatically verified by having an integer variable `countAddition` (initialized to 0) and incrementing this variable each time an addition is performed. With these changes the program fragment looks like,

```
int countAddition = 0;
d = 0;
for(i=1; i<31; ++i, ++countAddition) //To account for the addition in ++i
for(j=1; j<31; ++j, ++countAddition) //To account for the addition in ++j
for(k=1; k<31; ++k, ++countAddition) //To account for the addition in ++k
    if(((i + j + k) %3) == 0)
    {
        d = d+1;
        ++countAddition; // To account for the addition in d = d+1
        ++countAddition; // To account for the addition in i + j
        ++countAddition; // To account for the addition in j + k
    }
else
{
    ++countAddition; // To account for the addition in i + j
    ++countAddition; // To account for the addition in j + k
}
printf("%d",d);
printf("\n%d", countAddition);
```

The value of the variable `countAddition` that is printed by the last statement is the answer.

Chapter 2

UNIX

- UNIX was developed by
 - Bell Labs
 - Berkley Software Group
 - California University
 - American Defence Academy
- Chocolate Chip is
 - a latest Intel product
 - another name for BSD 4.2 Version
 - another name for System V
 - another name for System III
- Which of the following features of UNIX may be used for inter process communication?
 - Signals
 - Pipes
 - Semaphore
 - Message Queues
- Pick the incorrect statements.
 - Shell is a command interpreter.
 - Shell is the interface between user and kernel.
 - System can't work without a shell.
 - Shell is a program.
- UNIX is
 - a multi-user system
 - a real-time system
 - a multi-task system
 - name of a file in the root directory
- *6. Which of the following statements best explains a process?
 - It is a program.
 - It is a program in execution.
 - It is an instance of a program in execution.
 - It is a program that uses system calls.
- *7. In a system, if 5 people are currently using the vi editor, then the number of corresponding processes will be
 - 1
 - 5
 - 2
 - 0

- Which of the following is not a field in the Ethernet message packet?
 - Type
 - Data
 - Pin-code
 - Address
- The network topology that supports bi-directional links between each possible node is
 - ring
 - star
 - tree
 - mesh
- In a broad sense, a railway track is an example of
 - simplex
 - half-duplex
 - full-duplex
 - all of the above
- The frequency range at which the land coaxial cables will be used is
 - 10^6 to 10^8 Hz
 - 10^{10} to 10^{11} Hz
 - 10^3 to 10^4 Hz
 - 10^{14} to 10^{15} Hz
- If the data rate of ring is 20 Mbps, signal propagation speed is 200 m/ μ s, then the number of bits that can be placed on the channel of 200 km is
 - 2000 bits
 - 20,000 bits
 - 1,000 bits
 - none of the above
- ICI (interface control information) is
 - used to transfer user data from layer to layer
 - used to exchange information by peer entities at different sites on the network to instruct an entity to perform a service function
 - a combination of service data unit (SDU) and protocol control information (PCI)
 - a temporary parameter passed between N and $N - 1$ layers to involve service functions between two layers
- Match the following
 - Data link layer
 - the lowest layer whose function is to activate, deactivate and maintain the circuit between DTE and, DCE
 - performs routing and communication
 - detection and recovery from errors in the transmitted data
 - Provides for the syntax of the data
 - Physical layer
 - Presentation layer
 - Network layer
 - 1-(iii), 2-(i), 3-(iv), 4-(ii)
 - 1-(ii), 2-(i), 3-(iv), 4-(iii)
 - 1-(iv), 2-(i), 3-(ii), 4-(iii)
 - 1-(ii), 2-(i), 3-(iii), 4-(iv)

Answers

- | | | | | |
|----------|----------|----------|----------|----------|
| 1. a | 2. d | 3. b | 4. d | 5. d |
| 6. c | 7. c | 8. b | 9. b, c | 10. c, d |
| 11. a, b | 12. a, c | 13. a, b | 14. a, c | 15. c, d |
| 16. a | 17. b | 18. b | 19. c | 20. a, d |
| 21. a, b | 22. a | 23. b | 24. c | 25. a |
| 26. b | 27. b | 28. b | 29. c | 30. c |
| 31. b | 32. b | 33. b | 34. c | 35. a |
| 36. a | 37. b | 38. a, b | 39. b | 40. c |

44. The _____ measures the number of lost or garbled messages as a fraction of the total sent in the sampling period.
- Residual Error rate
 - Transfer failure probability
 - Connection release failure probability
 - Connection establishment failure probability
45. In session layer, during data transfer, the data stream responsible for the control purpose (i.e. control of the session layer itself) is
- regular data
 - typed data
 - capability data
 - expedited data

The next three questions are based on Huffman's coding for the symbol A with probability 0.3, B with 0.15, C with 0.1, D with 0.25 and E with 0.2.

- *46. The minimum number of bits required to represent B is
- 1
 - 2
 - 3
 - 4
- *47. The minimum number of bits required to represent all the symbols together is
- 14
 - 11
 - 12
 - 15
- *48. The average code length of the given problem is
- 2
 - 2.25
 - 2.45
 - 3
49. In cryptography, the following uses transposition ciphers and the keyword is LAYER. Encrypt the following message. (Spaces are omitted during encryption)
- WELCOME TO NETWORK SECURITY!
- WMEKREETSILTWETCOOCYONRU!
 - EETSICCOOCYWMEKRONRU!LTWET
 - LTWETONRU!WMEKRCOOCYEETSI
 - ONRU!COOCYLTWETEETSIWMEKR
50. Encrypt NEKEWNINRROGTTI using the above keyword in Transposition cipher method.
- INTERWORKINGNET
 - INTERNETWORKING
 - WORKINGINTERNET
 - None of the above
51. Assuming that for a given network layer implementation, connection establishment overhead is 100 bytes and disconnection overhead is 28 bytes. What would be the minimum size of a packet the transport layer needs to keep up, if it wishes to implement a datagram service above the network layer and needs to keep its overhead to a maximum of 12.5%. (Ignore transport layer overhead.)
- 512 bytes
 - 768 bytes
 - 1152 bytes
 - 1024 bytes
52. Which of the following is not a standard RS-232C signal?
- RTS
 - CTS
 - DSR
 - VDR
53. A high speed communication equipment typically would not be needed for
- E-mail
 - transferring large volume of data
 - supporting communication between nodes in a LAN
 - all of the above
54. Which of the following ISO level is more closely related to the physical communications facilities?
- Application
 - Session
 - Network
 - Data link

8. Kernel is not involved
- when a read operation is done
 - when a pressed key is echoed on to the screen
 - in resource allocation
 - none of the above
- *9. The command
- ```
echo welcome > /dev/tty
```
- echoes welcome in all the terminals that are switched on.
  - echoes welcome in all the terminals that are logged on.
  - echoes welcome only in the terminal in which it is run.
  - signals the error message - Terminal number not specified.
- \*10. /dev/null
- is a file
  - has write permission for all
  - is the UNIX built-in dustbin
  - none of the above
11. The advantage of binary files over text files is that
- it is compact
  - it can be accessed faster
  - many commands (like cat) assume the named file to be a binary file.
  - they are more reliable
- \*12. The permission bits of a file noname, can be set to `_rws_ _x_ _x` by the command.
- `chmod 711 noname`
  - `chmod go-rw noname`
  - `chmod 2711 noname`
  - none of the above
- \*13. /bin/passwd has the user execution permission set to 's' because
- it is not executable
  - it should allow users who don't have write permission to /etc/passwd to write to it
  - /etc/passwd is write protected
  - this facility assigns to the user, permissions of the program owner, temporarily.
14. If one doesn't want anyone else to read or write to a file named datfile, except through a program in file filex, then he may use
- `chmod u+s filex ; chmod go-rw datfile`
  - `chmod u+s datfile ; chmod go-rw filex`
  - `chmod 4711 datfile ; chmod go-rw filex`
  - `chmod 4711 filex ; chmod go-rw datfile`
15. Writing a C program that accepts input from keyboard, rather than from a file is advantageous because
- keyboard is a file that is already open
  - it facilitates batch processing
  - it can be used in a pipe, if it writes to stdout
  - none of the above



- \*16. Consider the following command that invokes the executable file `a.out`, with the following command line arguments `a.out God loves you`  
`argv[1][2]` corresponds to the character  
 (a) e (b) o (c) . (d) d
- \*17. In the previous question after the operation `argv++`, the value of `argv[1][2]` will be  
 (a) e (b) d (c) v (d) undefined
- \*18. Which of the following string functions can be used to find the last occurrence of a given character in a given string?  
 (a) `strncmp` (b) `strncpy` (c) `strchr` (d) None of the above
19. Choose the correct statements.  
 (a) The function `stat` refers a file by its name.  
 (b) The function `stat` refers a file by its file descriptor.  
 (c) The function `fstat` refers a file by its file descriptor.  
 (d) The function `fstat` refers a file by its name.
20. Which of the following fields in the structure `stat`, has information about the permission setting of a file?  
 (a) `st_gid` (b) `st_mode` (c) `st_ino` (d) `st_uid`
- \*21. To simulate the command "system", which of the system calls - `fork`, `wait`, and `exec` is/are to be used?  
 (a) `fork` and `wait` (b) all three  
 (c) `fork` and `exec` (d) `wait` and `exec`
22. Consider the program
- ```
main()
{
    printf("He arose a victor from\n");
    system("date");
    printf("the dark domain");
}
```
- If `a.out` is the executable code corresponding to the above source code, then the command `a.out > outf`
 (a) redirects the output of `date` to file `outf`
 (b) displays the output of `date` on the screen
 (c) prints everything on the screen
 (d) prints the two messages on the screen
23. The default permission bits of a file when it is created for the first time, is controlled by
 (a) `chmod` value (b) `fmask` value (c) `umask` value (d) none of the above
- *24. Let `x.c` be a C source code. The command `cc x.c > y`
 (a) is equivalent to the command `cc x.c ; mv a.out y`
 (b) is equivalent to the command `cc -o y x.c`

27. Which one of the following network uses dynamic or adaptive routing?
 (a) TYMNET
 (b) ARPANET
 (c) SNA (IBM's System Network Architecture)
 (d) None of the above
- *28. The number of cross point needed for 10 lines in a cross point switch which is full duplex in nature and there are no self connection is
 (a) 100 (b) 45 (c) 50 (d) 90
- *29. A terminal multiplexer has six 1200 bps terminals and 'n' 300 bps terminals connected to it. The outgoing line is 9600 bps. What is the maximum value of n?
 (a) 4 (b) 16 (c) 8 (d) 28
30. The difference between a multiplexer and a statistical multiplexer is:
 (a) Multiplexers use TDM (time division multiplexing), while statistical multiplexer uses FDM (frequency division multiplexing).
 (b) Multiplexers often waste the output link capacity, while statistical multiplexers optimize its use.
 (c) Statistical multiplexers need buffers while multiplexers do not need buffers.
 (d) Multiplexers use the X.25 protocol, while statistical multiplexers use the ALOHA protocol.
31. A modem constellation diagram has data points at (0, 1) and (0, 2). What type of modulation does the modem use?
 (a) Phase modulation (b) Amplitude modulation
 (c) Both (a) and (b) (d) None of the above
32. Write the differential Manchester code for the given sketch
 (a) 111100101 (b) 100010111 (c) 101001111 (d) 101001101



- *33. Maximum data rate of a channel for a noiseless 3-kHz binary channel is
 (a) 3000 bps (b) 6000 bps (c) 1500 bps (d) none of the above
- *34. The maximum data rate of a channel of 3000-Hz bandwidth and SNR of 30 dB is
 (a) 15,000 bps (b) 60,000 bps (c) 30,000 bps (d) 3,000 bps
- *35. In time division switches if each memory access takes 100 ns and one frame period is 125 μs, then the maximum number of lines that can be supported is
 (a) 625 lines (b) 1250 lines (c) 2300 lines (d) 318 lines
36. If the bit string 0111101111101111110 is subjected to bit stuffing for the flag string 01111110, the output string is
 (a) 011110111110011111010 (b) 01111011111011111100
 (c) 01111011111011111010 (d) 0111101111101111110

- (c) the rate at which the signal changes
(d) none of the above
7. Start and stop bits are used in serial communication for
(a) error detection (b) error correction
(c) synchronization (d) slowing down the communication
8. Unmodulated signal coming from a transmitter is known as
(a) carrier signal (b) baseband signal (c) primary signal (d) none of the above
- *9. Manchester code is a
(a) Bi-polar code (b) non return to zero code
(c) polar code (d) none of the above
10. Pick the incorrect statements.
(a) Another name for primary/secondary protocol is master/slave.
(b) Peer to peer protocol provides equal status to all sites on the channel.
(c) Priority, non-priority types come under master/slave protocol.
(d) TDM is a primary/secondary non-priority system.
11. Pick the correct statements.
(a) A switched circuit is a dial-up circuit that may encounter blockage (busy signal).
(b) Non switched leased line supports higher data volume and quality than switched lines.
(c) Non switched lines are expensive for high volume data.
(d) Switched circuit provides faster response time.
12. Pick the incorrect statements that pertain to error retransmission used in continuous ARQ method.
(a) Go-back-N method requires more storage at the receiving site.
(b) Selective Repeat involves complex logic than Go-back-N.
(c) Go-back-N has better line utilisation.
(d) Selective Repeat has better line utilisation.
13. In the carrier sense network if the prevailing condition is a 'channel busy', then which of the following are correct?
(a) If the technique used is non-persistent then it results in randomised wait and sense.
(b) If the technique used is 1-persistent then the channel is continually sensed.
(c) If the technique used is p-persistent then randomised retransmission is done.
(d) If the method used is non-persistent then continuous sensing results.
14. Which of the following are non-polling systems?
(a) TDMA (b) Stop and Wait
(c) Xon/Xoff (d) Continuous ARQ
15. Pick the systems that can be used in both priority and non-priority modes.
(a) TDM (b) Register insertion
(c) Carrier sense systems (d) Token passing
- *16. How many characters per sec (7 bits + 1 parity) can be transmitted over a 2400 bps line if the transfer is synchronous (1 start and 1 stop bit)?
(a) 300 (b) 240 (c) 250 (d) 275

- (c) serves no purpose
(d) none of the above
25. Which of the following sections in the manual covers system calls?
(a) 1 (b) 2 (c) 3 (d) 4
26. Which of the following are not system calls?
(a) chmod (b) open (c) lseek (d) getc
27. Choose the correct statements.
(a) C programs can directly make system calls.
(b) System calls are functions used by the shell.
(c) Library functions use system calls.
(d) Library functions don't use system calls.
28. Which of the following remarks about system calls, library functions and UNIX commands are true?
(a) System call is a part of kernel, while the other two are not a part of kernel
(b) Unlike library functions, system calls and Unix commands are stand-alone programs
(c) Library functions and UNIX commands use system calls
(d) Unlike system calls, library functions and UNIX commands are stand-alone programs
29. The 2 in the manual entry `access(2)`
(a) implies `access` is a system call (b) implies `access` is a library function
(c) refers to the section number (d) none of the above
30. If path is set to `./usr/x:/usr/bin`, then
(a) the command one types will be first checked in the current directory, then `/usr/x` and `/usr/bin`.
(b) if a command is found in both `/usr/x` and `/usr/bin`, then the one in `/usr/x` will be executed.
(c) in the previous choice, what happens is unpredictable.
(d) if a command is found in both `/usr/x` and `/usr/bin`, then the one in `/usr/bin` will be executed.
- *31. A file `x` is created with the following contents

```
echo today is:
date
```

 If you type `x`, then
(a) it echoes the message, followed by date.
(b) it gives the desired output only if the `execute` permission of file `x` is set.
(c) the desired output can be got by the command `sh x`, which works even if `x` has its `execute` permission not set.
(d) none of the above.

32. Shell script is preferable to other forms of programming because it
- (a) executes faster
 - (b) enhances portability
 - (c) occupies less space
 - (d) makes programming task easier
33. Choose the incorrect statements.
- (a) Shell scripts can accept arguments
 - (b) Shell scripts are interpreted
 - (c) Shell is a programming language
 - (d) Shell scripts are compiled
34. Files that store data in the same format as used in program are called
- (a) binary files
 - (b) source file
 - (c) text file
 - (d) core
35. To allow only one user to work with a particular file at a particular time, one has to use
- (a) semaphore
 - (b) critical region
 - (c) locking
 - (d) dedicated mode
36. Which of the following remarks about `realloc` are true?
- (a) It allocates memory of required size that need not be contiguous
 - (b) It never shifts the existing block
 - (c) It can work only with an existing block of memory
 - (d) It may shift the existing block
37. The differences between `malloc()` and `calloc()` are:
- (a) `malloc` is used for dynamic allocation of memory, while `calloc` can't be used for that purpose.
 - (b) `malloc` needs only one argument, while `calloc` needs two.
 - (c) unlike `malloc`, `calloc` allocates memory and initializes it to 0.
 - (d) `malloc` needs two arguments and `calloc` only one.
38. The file that stores an integer as a sequence of characters is a
- (a) text file
 - (b) data file
 - (c) binary file
 - (d) core
39. If `cat x`, prints garbage, then `x` is probably a
- (a) data file
 - (b) binary file
 - (c) text file
 - (d) source file
- *40. Which of the following file names can be found in more than one directory?
- (a) `passwd`
 - (b) `bin`
 - (c) `date`
 - (d) none of the above
41. `/bin`
- (a) is a bucket for storing information
 - (b) has files in binary code
 - (c) is a directory
 - (d) none of the above
42. The main reasons for the success of pipes are
- (a) the availability of many filter programs
 - (b) UNIX treats devices as files
 - (c) it provides a 2-way communication channel
 - (d) all of the above
43. Which of the following are not filter programs?
- (a) `date`
 - (b) `sort`
 - (c) `cat`
 - (d) `grep`

Chapter 14

Computer Networks

1. Protocols are
 - (a) agreements on how communication components and DTE's are to communicate
 - (b) logical communication channels used for transferring data
 - (c) physical communication channels used for transferring data
 - (d) none of the above
2. The method of communication in which transmission takes place in both directions, but only in one direction at a time is called
 - (a) simplex
 - (b) four wire circuit
 - (c) full duplex
 - (d) half duplex
3. Error detection at the data link level is achieved by
 - (a) bit stuffing
 - (b) cyclic redundancy codes
 - (c) Hamming codes
 - (d) equalization
4. Which of the following is a wrong example of a network layer?
 - (a) Internet Protocol (IP)-ARPANET
 - (b) X.25 Packet Level Protocol (PLP)-ISO
 - (c) Source routing and domain naming-USENET
 - (d) X.25 level 2-ISO
5. The topology with highest reliability is
 - (a) bus topology
 - (b) star topology
 - (c) ring topology
 - (d) mesh topology
6. baud means
 - (a) the number of bits transmitted per unit time
 - (b) the number of bytes transmitted per unit time

- | | | | | |
|-------|----------|-------------|----------|----------|
| 46. d | 47. c | 48. a, b, c | 49. d | 50. d |
| 51. d | 52. d | 53. c | 54. c | 55. b |
| 56. d | 57. a, c | 58. a | 59. b | 60. b |
| 61. d | 62. c | 63. b | 64. a, b | 65. a, b |
| 66. d | | | | |

Explanations

- When C++ was developed, it did not have a compiler. It used `cfront`, which translated the C++ code into a C code and then the existing C compiler was used to compile the program originally written in C++.
- `::` is basically meant to manipulate a global variable, in case a local variable also has the same name.
- Procedural languages sequentially execute a set of imperative statements to achieve the desired effect. Most of the traditional languages fall in this category.
- Both the arguments are optional. All the calls are legal.
- Reusable code is an already used code, as the name implies. Hence it is bug-free and pre-tested. There is no need to test it.
- Each occurrence of the `inline` function call will be replaced by its body. No function call overhead will be there but the size of the code will increase.
- The symbol `<<` has a context sensitive meaning. The `<<` in `(a<<2)` means shifting `a` by 2 bits to the left, which is nothing but multiplying it by 4. So, `a<<2` will be $5 \times 4 = 20$ and hence the output will be `FIRST20SECOND`.
- Since destructors do not take arguments, the question of overloading does not arise at all.
- `int &p=x` aliases `p` to `x`. This means they refer to the same memory location. So, the address of `x` will be same as that of `p`.
- In the first declaration, `p` is aliased to `x`. In the second case, `p` is a separate variable and it will have an address that is different from that of `x`.
- The very idea of declaring `b` as a constant integer is to protect it from changes. However, since it is aliased to a variable whose attribute is not `const`, the value of `b` can be indirectly changed by changing the value of `a`. This is a bad programming practice.
- C++ forbids initialization with strings, whose length is more than the size of the array. A C compiler permits.
- Since the second argument is mandatory, any call should have at least the first two parameters. Some compilers expect the optional parameters to follow the others. Such compilers give a compilation error.
- Here the `default` parameter passing mechanism of pass by value will be used. Any change done to the parameter will not be reflected outside the function. So, `b` retains its value 2.
- Here the parameter passing mechanism is pass by reference. Any change done to the parameter will be reflected outside the function. So, the value of `b`, after the `exit` of the function will be 10.

- Redirection in pipes can be achieved by using
 - `>`
 - `>>`
 - `tee`
 - `lpr`
- Choose the correct statements.
 - The symbols `>` and `|` are both processed by shell
 - `>` can be used to direct output to a named file
 - `|` can be used to direct output to programs
 - Filter programs can be piped
- The command `who | sort - file1 > file2`
 - results in an error
 - sorts the contents of `file1` and puts it in `file2`
 - puts in `file2`, the sorted output of `who`, followed by sorted contents of `file1`
 - none of the above
- If the command `cat x`, is executed after successfully executing the command `time sort filename > x`, then
 - only the time details will be displayed
 - only the sorted contents of the file `filename` will be displayed
 - an error message will be displayed
 - the sorted contents of the file `filename`, along with the time information will be displayed
- Which of the following information is not present in an i-node?
 - Contents of the file
 - Size of the file
 - Name of the file
 - Permission setting of the file
- The system identifies a file by its
 - name
 - absolute path
 - file owner
 - inode number
- The system identifies the end of a file by the
 - EOF character
 - file size
 - i-node number
 - none of the above
- The command line argument `a.out x 'a b' "c d"`
 - is acceptable
 - is acceptable if the double quotes are replaced by single quotes
 - is acceptable if the single quotes are replaced by double quotes
 - none of the above
- Which of the following metacharacters will be recognized by the shell, even if it comes within double quotes?
 - `$`
 - `*`
 - `?`
 - None of these
- `lint` should be used
 - before compilation
 - after compilation
 - to analyze a C code
 - none of the above

54. Environment variables can be accessed by
 (a) system programs (b) C programs
 (c) shell scripts (d) none of the above
55. Which of the following are character special files?
 (a) Terminal (b) Printer (c) Modem (d) Tape Drive
56. If one exports a variable
 (a) variables placed in the environment by a child process are not inherited by the parent process.
 (b) it is passed to all its descendant processes
 (c) it dies when the shell that created it dies
 (d) only the first two choices are correct
57. Profilers are
 (a) tools that analyze the run time behaviour of a program
 (b) tools that check a C code for cross file consistency
 (c) tools that keep track of evolving versions of a file
 (d) none of the above
58. The shell command :
 (a) does nothing
 (b) can be used to cause infinite looping
 (c) can take arguments but it cannot act on them
 (d) can be used to indicate a comment
- *59. Which of the following tools can be used to keep track of evolving versions of a file?
 (a) make (b) yacc (c) sccs (d) dv
- *60. The . (dot) shell command
 (a) can take command line argument
 (b) will fork a child shell to execute the named shell script
 (c) can be used to change the environment of the current shell
 (d) all of the above
- *61. m4
 (a) is a macro processor
 (b) can be used to preprocess C code
 (c) can be used to preprocess assembly language program
 (d) none of the above
- *62. The first thing that is searched when a command references a file is its
 (a) i-node (b) i-node number
 (c) permission setting (d) none of the above

const char *naa;

Which of the following statements

Statement I: aa = a;

Statement II: na = &a;

Statement III: na = &aa;

is/are illegal?

- (a) Only I and II (b) Only II and III
 (c) Only I and III (d) All the three statements are illegal

54. Forgetting to include a file (like cmath or math.h) that is necessary will result in

- (a) compilation error (b) warning when the program is run
 (c) error at link time (d) warning when the program is compiled

*55. Assume that the random number generating function – rand(), returns an integer between 0 and 10000 (both inclusive). If you want to simulate the throwing of a die using this random function, use the expression

- (a) rand() % 6 (b) rand() % 6 + 1
 (c) rand() % 5 + 1 (d) none of the above

*56. Assume that the random number generating function – rand(), returns an integer between 0 and 10000 (both inclusive). To randomly generate a number between a and b (both inclusive), use the expression

- (a) rand() % (b-a) (b) (rand() % a) + b
 (c) (rand() % (b-a)) + a (d) (rand() % (b-a+1)) + a

57. Which of the following comments about inline comments are true?

- (a) A function is declared inline by typing the keyword *inline* before the return value of the function.
 (b) A function is declared inline by typing the keyword *inline* after the return value of the function.
 (c) A function that is declared inline may not be treated inline.
 (d) Inline functions are essentially same as implementing a function as macro.

58. Which of the following decides if a function that is declared inline is indeed going to be treated inline in the executable code?

- (a) Compiler (b) Linker (c) Loader (d) Preprocessor

*59. Which of the following type of functions is an ideal candidate for being declared *inline*?

- (a) A function that is small and is not called frequently.
 (b) A function that is small and is called frequently.
 (c) A function that is not small and is not called frequently.
 (d) A function that is not small and is called frequently.

*60. One of the disadvantages of pass-by reference is that the called function may inadvertently corrupt the caller's data. This can be avoided by

- (a) passing pointers (b) declaring the formal parameters constant
 (c) declaring the actual parameters constant (d) all of the above

```
void main( )
{
    def x1;
    abc x2;
    x2.mn(x1);
}
```

- (a) will compile successfully if statement 1 is removed
 (b) will compile successfully if statement 2 is removed
 (c) will compile successfully if statement 3 is removed
 (d) will run successfully and print 345

The next two questions are based on the following C++ program.

```
#include "iostream.h"
int a(int m)
{ return ++m; }
int b(int &m)
{ return ++m; }
int c(char &m)
{ return ++m; }
void main( )
{
    int p=0, q=0, r=0;
    p += a(b(p));
    q += b(a(q));
    r += a(c(r));
    cout << p << q << r;
}
```

51. The above program
 (a) results in compilation error
 (b) prints 123
 (c) prints 111
 (d) prints 322
52. If the statement
`q += b(a(q));` is replaced by the statement
`q += b(a(p));` then the above program
 (a) prints 111
 (b) results in compilation error
 (c) prints 322
 (d) prints 352
53. Consider the declarations
`char a;`
`const char aa = 'h';`
`char *na;`

63. `cc` command sequentially invokes
 (a) preprocessor, compiler and link editor
 (b) compiler and link editor
 (c) preprocessor, compiler, assembler and link editor
 (d) compiler, assembler and link editor
- *64. Among the directory entries, i-node and the file contents, which will be changed when a file is updated?
 (a) Only directory entry and file contents
 (b) Only i-node and file contents
 (c) All the three
 (d) None of the above
65. The `cc` command
 (a) can take more than one argument
 (b) can act on files with `.c` or `.o` extension
 (c) creates `.o` files by default when more than one argument with `.c` extension is present
 (d) if provided with more than one argument, immediately terminates if the first argument fails to compile successfully
- *66. The `mv` command changes
 (a) only the directory entry
 (b) only the directory entry and i-node
 (c) only the i-node number
 (d) none of the above
67. If 7 terminals are currently logged on, then the command
`date ; who | wc -l`, displays
 (a) date followed by 7
 (b) date followed by 8
 (c) date followed by 1
 (d) an error message
- *68. Choose the correct answers if the command `ls -l /dev/mt0` displays
`brw-rw_ _ _ _ 1 root 3, 0 jan 18 11:05 mt0`
 (a) The 'b' indicates that it is a special file
 (b) `mt0` indicates that it is a tape drive
 (c) `mt0` indicates that it is a mounted tape
 (d) The 'b' indicates that data transfer is done in blocks
69. Choose the correct statements.
 (a) `ld x.o` is a valid command (assume `x.o` exists)
 (b) `ld x.o` is same as `cc x.o`
 (c) `cc x.s` is a valid command (assume `x.s` exists)
 (d) All of the above
- *70. `cat /dev/tty`
 (a) throws garbage onto the terminal `tty`
 (b) just echoes what you type, line by line
 (c) terminates if one types control `d`, at the beginning of a line
 (d) terminates if one types control `d`, anywhere in a line

71. The header files used in C programs are usually found in
 (a) /bin/include (b) /usr/bin/include
 (c) /dev/include (d) /usr/include
72. The command `pwd` displays `/x/y`. After executing the command `chmod u-x`, which of the following commands will not work?
 (a) `cd ..` (b) `ls` (c) `chmod u+x` (d) `pwd`
73. A C program should be compiled with `-g` option (like `cc -g x.c`) to use
 (a) `prof` (b) `make` (c) `lprof` (d) `sdb`
74. The difference between a pipe and a regular file is that
 (a) unlike a regular file, pipe is not a file.
 (b) the data in a pipe is transient, unlike the contents of a regular file.
 (c) pipes forbid random accessing, while regular files do allow this.
 (d) all of the above.
75. Choose the correct statements.
 (a) The default linking arrangement for `cc` is dynamic.
 (b) Dynamically linked programs save disk storage.
 (c) Dynamically linked programs enhances shareability of library routines.
 (d) Dynamically linked programs can be fixed or enhanced without relinking the applications that depend on it.
76. Context switch changes the process mode from
 (a) user to kernel mode
 (b) kernel to user mode
 (c) kernel mode to the kernel process
 (d) kernel process to the kernel mode of some process
77. File `x.c` has 5 lines of code. The command
`date | tee abc | sort -x.c | wc -l`, displays
 (a) 5 (b) 6 (c) 0 (d) an error message
78. Which of the following comments about the signals system call are true?
 (a) It takes up two arguments
 (b) The second argument, is a function call
 (c) The second argument is a pointer to a function
 (d) The first argument is an integer
79. `lint` can analyze the named source code for
 (a) inconsistent usage (b) non portability
 (c) suspicious constructs (d) none of the above
80. Which of the following characteristics of the original process are preserved when, the `exec` system call is executed?
 (a) The current working directory (b) The open files
 (c) PID (d) PPID

the output will be

- (a) There was There was
 (b) nothing
 (c) There was There was a certain man
 (d) There was a certain man There was a certain man

The next two questions are based on the following program segment.

```
class A
{ int i1;
  protected:
  int i2;
  public:
  int i3;
};
class B : public A
{ public:
  int i4;
};
class C : B
{
};
```

48. The variable `i2` is accessible
 (a) to a public function in class A (b) to a public function in class B
 (c) to a public function in class C (d) from the main function
49. Which variable(s) is/are accessible from the main function?
 (a) `i1` (b) `i2` (c) `i3` (d) None of the above
- *50. The following program

```
class abc;
class def
{ int i1; // statement 1
  protected: int i2; // statement 2
  public: int i3; // statement 3
  friend abc;
};
class abc
{ public:
  void main(def A)
  {cout << (A.i1=3); cout << (A.i2=4); cout << (A.i3=5)}
};
```

The next three questions are based on the following information.

```
int a=1, b=2;
a = chg(b);
cout << a << b;
```

*31. If the function chg is coded as

```
int chg(int x)
{
    x = 10;
    return (11);
}
```

then

- (a) it results in compile-time error (b) it results in run time error
(c) it prints 112 (d) it prints 1110

*32. If the function chg is coded as

```
int chg(int &x)
{
    x = 10;
    return(11);
}
```

then

- (a) it results in compile-time error (b) it results in run time error
(c) it prints 112 (d) it prints 1110

*33. If the function chg is coded as

```
int chg(const int &x)
{
    x=10;
    return(11);
}
```

then

- (a) it results in compile-time error (b) it results in run time error
(c) it prints 112 (d) it prints 1110

34. Choose the correct statements from the following:

- (a) In a struct, the access control is public by default.
(b) In a struct, the access control is private by default.
(c) In a class, the access control is public by default.
(d) In a class, the access control is private by default.

*81. Which of the following remarks about lex are true?

- (a) It generates a C program.
(b) It produces a C code that consumes more memory than a C program that can be written separately to accomplish the same task.
(c) It produces a C code that executes slower than a C program that can be written separately to accomplish the same task.
(d) None of the above.

82. Which of the following programs are not interactive?

- (a) passwd (b) date (c) grep (d) sh

83. lex can be used for

- (a) text processing
(b) code enciphering
(c) compiler construction
(d) collecting statistical data of different patterns

*84. The number of errors in the following shell script

```
echo How are you ?
read $answer
```

is

- (a) 0 (b) 1 (c) 2 (d) 3

85. The read in the previous question is a

- (a) library function (b) system call (c) shell command (d) none of the above

86. If lex.l is a lex code then

- (a) the command lex lex.l invokes lex to act on lex.l
(b) the command lex lex.l writes its output to the file lex.yy.c
(c) lex.yy.c has the definition of the function yylex
(d) lex library can be invoked by the compiler option ll

87. Choose the correct statements.

- (a) Any process has an associated owner ID and group ID.
(b) Effective ID defines who you are for the duration of a process.
(c) Real ID defines who you are for the duration of a process.
(d) Effective ID is available in /etc/passwd file.

*88. A file hai has the following shell script in it

```
echo Oh! What a wonderful day
echo Day I will never forget 1>&2
echo Day I will never ever get
```

The command sh hai > mn

- (a) puts all the three messages in mn
(b) puts the second message both in mn and the screen

- (c) puts only the first and the third message in mn
 (d) results in an error
- *89. No shell script can take input from
 (a) stdin
 (b) the output of the previously executed command redirected to it
 (c) the file that holds the script
 (d) none of the above
- *90. The command `cc x.c && a.out`
 (a) is equivalent to `cc x.c ; a.out`
 (b) means execute `a.out` only when `x.c` compiles successfully
 (c) means execute `a.out` only if `cc x.c` returns a value 0 to the system
 (d) all of the above
91. Which of the following shell script's looping features does not recognize the `break` command?
 (a) while (b) until (c) for (d) None of the above
92. Shell script
 (a) needs no compilation
 (b) is ideal for manipulating a file, character by character
 (c) is not good in arithmetic operations
 (d) enhances portability
93. The desirable features of a new shell script you write is that
 (a) it should take its input from `stdin`
 (b) on successful termination, it should exit with a non-zero value
 (c) it should not accept command line arguments
 (d) it does some cleaning up operation, on termination
94. Which of the following shell commands displays the contents of each of the command line arguments, one by one?
 (a) `cat $*` (b) `cat '$*'` (c) `cat "$@"` (d) `cat "$**"`
95. The disadvantage of a pipe is that
 (a) it is a one way communication channel
 (b) it dies along with the process that created it
 (c) it can't be shared by unrelated processes
 (d) none of the above
96. The state of signals are
 (a) preserved across a `fork` call
 (b) not preserved across a `fork` call
 (c) not preserved across an `exec` call
 (d) preserved across an `exec` call

12. A constructor is called whenever
 (a) an object is declared (b) an object is used
 (c) a class is declared (d) a class is used
- *13. Which of the following remarks about the differences between constructors and destructors are correct?
 (a) Constructors can take arguments but destructors cannot.
 (b) Constructors can be overloaded but destructors cannot be overloaded.
 (c) Destructors can take arguments but constructors cannot.
 (d) Destructors can be overloaded but constructors cannot be overloaded.
- *14. The following program fragment

```
void main( )
{
    int x=10;
    int &p=x;
    cout << &p << &x;
}
```

 (a) prints 10 and the address of x (b) results in a run time error
 (c) prints the address of x twice (d) prints the address of p twice
- *15. The declaration

```
int x; int &p=x;
```

 is same as the declaration

```
int x,*p; p=&x;
```

 This remark is
 (a) true (b) false (c) sometimes true (d) none of the above
16. The following program segment

```
const int m=10;
int &n=m;
n=11;
cout << m << n;
```

 (a) results in compile time error (b) results in run time error
 (c) prints 1111 (d) prints 1011
- *17. The following program segment

```
int a=10;
int const &b=a;
a=11;
cout << a << b;
```

 (a) results in compile time error (b) results in run time error
 (c) prints 1111 (d) none of the above

- *4. Which of the following are procedural languages?
 (a) Pascal (b) Smalltalk (c) C++ (d) C
- *5. A function `abc` is defined as

```
void abc(int x=0, int y=0)
{ cout << x << y; }
```

 Which of the following function calls is/are illegal? (Assume `h, g` are declared as integers)
 (a) `abc()`; (b) `abc(h)`; (c) `abc(h,h)`; (d) None of the above
6. The following C++ code results in

```
#include "iostream.h"
void main(void)
{
    cout << (int i=5) << (int j=6);
}
```

 (a) compilation error
 (b) run time error
 (c) link time error
 (d) none of the above
- *7. Reusability is a desirable feature of a language as it
 (a) decreases the testing time (b) lowers the maintenance cost
 (c) reduces the compilation time (d) reduces the execution time
- *8. Choose the correct statements regarding `inline` functions.
 (a) It speeds up execution (b) It slows down execution
 (c) It increases the code size (d) It decreases the code size
9. If many functions have the same name, which of the following information, if present, will be used by the compiler to invoke the correct function to be used?
 (a) The operator `::` (b) The return value of the function
 (c) Function signature (d) None of the above
- *10. The statements

```
int a = 5;
cout << "FIRST" << (a<<2) << "SECOND";
```

 outputs
 (a) FIRST52SECOND (b) FIRST20SECOND
 (c) SECOND25FIRST (d) an error message
11. Choose the correct remarks.
 (a) C++ allows any operator to be overloaded.
 (b) Some of the existing operators cannot be overloaded.
 (c) Operator precedence cannot be changed.
 (d) All of the above.

97. A `fork` system call will fail, if
 (a) the previously executed statement is also a `fork` call.
 (b) the limit on the maximum number of processes in the system would be exceeded.
 (c) the limit on the maximum number of processes that can be under execution by a single user would be exceeded.
 (d) all of the above.
98. Which of the following options for the shell command `test` should be followed by the file descriptor?
 (a) `r` (b) `d` (c) `t` (d) `s`
99. Which of the following displays the `exit` status of the last executed command?
 (a) `echo $#` (b) `echo $$` (c) `echo $?` (d) `echo $!`
- *100. Which of the following file names cannot be displayed if `ls *` is run?
 (a) `-Xy` (b) `?x` (c) `.x` (d) `hidden`
101. Which of the following initiates the sequence of events that ultimately allows a user to login?
 (a) `clri` (b) `sync` (c) `login` (d) `init`
- *102. `getc(stdin)`
 (a) results in run time error (b) results in syntax error
 (c) is equivalent to `getchar()` ; (d) none of the above
103. Which of the following is not the work of a C-preprocessor?
 (a) Macro expansion (b) File inclusion
 (c) Conditional compilation (d) None of the above
104. Which of the following is used to write disk block images from memory to disk?
 (a) `clri` (b) `sync` (c) `mkfs` (d) `stty`
- *105. Choose the correct statement.
 (a) To read successive characters from an open file, `getchar` and `scanf` can be used interchangeably.
 (b) To read successive characters from an open file, `getchar` and `read` can be used interchangeably.
 (c) The `read` system call reads from the buffer.
 (d) None of the above.
- *106. The following program

```
main()
{
    close(1);
    print("How R U?");
}
```

 (a) is syntactically incorrect (b) results in a run-time error
 (c) will wait indefinitely, if executed (d) none of the above

107. The PID of the kernel process is
 (a) undefined (b) 0 (c) 1 (d) 3
- *108. Choose the correct remarks.
 (a) `exit` and `return` can be used interchangeably
 (b) Use of `return` terminates the program
 (c) Use of `exit` terminates the program
 (d) `exit` returns a value to the system
109. Which of the following is an index to the array of open files maintained by the kernel for a user?
 (a) i-node (b) i-node number (c) File descriptor (d) File pointer
110. In which of the following directories does `init` reside?
 (a) `root` (b) `bin` (c) `etc` (d) `usr`
111. The command `cat > x`
 (a) is invalid
 (b) creates a file `x` and displays an error message
 (c) creates a file `x` and waits for the user to give input from the keyboard
 (d) none of the above
112. Which of the following are defined in `stdio.h`?
 (a) EOF (b) NULL (c) BUFSIZE (d) None of the above
113. The `login` prompt can be changed by changing the contents of the file
 (a) `inittab` (b) `init` (c) `passwd` (d) `gettydefs`
114. When the `read` system call encounters EOF, it returns
 (a) some positive integer (b) some negative integer
 (c) 0 (d) -1
115. Which of the following library functions do not return a pointer to the structure FILE?
 (a) `fopen` (b) `fclose` (c) `freopen` (d) `fwrite`
- *116. Which of the following processes are involved in the process of allowing a person to login?
 (a) `init` (b) `getty` (c) `login` (d) `kernel`
- *117. Which of the following system calls reads 8 bits from the standard input? (assume `buff` is a pointer to the buffer area)
 (a) `read(0, buff, 8)` (b) `read(1, buff, 8)`
 (c) `read(0, buff, 1)` (d) `read(1, buff, 1)`
118. Which of the following are implemented as macros (rather than functions)?
 (a) `getchar` (b) `getc` (c) `fgetc` (d) `fputc`
119. Choose the correct statements.
 (a) `errno` is an external variable available to any 'C' program
 (b) `errno` is set to a value when an error occurs
 (c) `errno` is cleared when a nonerroneous call is made
 (d) `errno` cannot be used to find the cause of an error

Chapter 13

Object Oriented Programming Using C++

1. C++ was originally developed by
 (a) Clocksin and Mellish (b) Donald E. Knuth
 (c) Sir Richard Hadlee (d) Bjarne Stroustrup
- *2. `cfront`
 (a) is the front end of a C compiler
 (b) is the pre-processor of a C compiler
 (c) is a tool that translates a C++ code to its equivalent C code
 (d) none of the above
- *3. The following program fragment
- ```
int i=10;
void main()
{
 int i=20;
 {
 int i=30.;
 cout << i << ::i;
 }
}
```
- (a) prints 3010 (b) prints 3020  
 (c) will result in a run time error (d) none of the above

The canonical cover for this set is

- (a)  $A \rightarrow BC$  and  $B \rightarrow C$                       (b)  $A \rightarrow BC$  and  $AB \rightarrow C$   
 (c)  $A \rightarrow BC$  and  $A \rightarrow B$                       (d)  $A \rightarrow B$  and  $B \rightarrow C$

50. Assume transaction  $A$  holds a shared lock  $R$ . If transaction  $B$  also requests for a shared lock on  $R$ , it will
- (a) result in a deadlock situation  
 (b) immediately be granted  
 (c) immediately be rejected  
 (d) be granted as soon as it is released by  $A$

### Answers

- |             |                |                |       |             |
|-------------|----------------|----------------|-------|-------------|
| 1. b        | 2. a, b, c     | 3. a           | 4. a  | 5. c        |
| 6. b        | 7. a           | 8. a, c        | 9. c  | 10. b       |
| 11. b       | 12. a,b,c,d    | 13. b          | 14. c | 15. a,b,c   |
| 16. c       | 17. a          | 18. d          | 19. c | 20. c       |
| 21. c       | 22. c          | 23. d          | 24. c | 25. c, d    |
| 26. d       | 27. c          | 28. a          | 29. a | 30. a, b, c |
| 31. a, b    | 32. a, b, c, d | 33. a          | 34. a | 35. a       |
| 36. a       | 37. c          | 38. a          | 39. d | 40. b       |
| 41. b       | 42. b          | 43. a, b, c, d | 44. d | 45. a, b, c |
| 46. a, b, c | 47. b          | 48. a,b,c      | 49. a | 50. b       |

### Explanations

18. The maximum number of tuples results when each of the 120 students enrolls for each of the 8 courses, giving  $120 \times 8 = 960$  tuples. The minimum number of tuples results when all the 120 students enroll for the same course, giving  $120 \times 1 = 120$  tuples.

120. When the user responds to login prompt
- (a) `getty` forks login process                      (b) login process replaces `getty` process  
 (c) a shell will be created                      (e) none of the above
121. The shell command `cat x y > x`
- (a) doesn't work  
 (b) replaces the contents of file  $x$ , by the contents of file  $y$   
 (c) does nothing, other than displaying an error message  
 (d) none of the above
122. Which of the following return file descriptor?
- (a) `close`                      (b) `fopen`                      (c) `open`                      (d) `creat`
123. To simulate the `who` command, one has to access the file
- (a) `/etc/passwd`                      (b) `/bin/.login`  
 (c) `/etc/utmp`                      (d) `/usr/user_dat`
124. A file system in UNIX has the four sections—boot block, super block, I-list and data block that are arranged in the order
- (a) boot block, super block, I-list and data block  
 (b) boot block, data block, super block and I-list  
 (c) boot block, data block, I-list and super block  
 (d) super block, boot block, data block and I-list
125. `stderr`, `stdout`, `stdin` have the file descriptors
- (a) 0, 1, 2 respectively                      (b) 0, 2, 1 respectively  
 (c) 1, 0, 2 respectively                      (d) 2, 1, 0 respectively
126. Which of the following functions can be used to randomly access a file?
- (a) `fgetc`                      (b) `getc`                      (c) `fseek`                      (d) `ftell`
127. A manual entry of the form `xyz(3S)`
- (a) implies `xyz` is a system call  
 (b) implies `xyz` is a library function  
 (c) means `xyz` is a library function that is part of the standard i/o package  
 (d) means `xyz` is a library function that is a part of the standard math library
128. The reference time adopted by UNIX is
- (a) Jan 1, 1970                      (b) Jan 1, 1980                      (c) Jan 1, 1982                      (d) Jan 1, 1972
- \*129. `perror()` can be simulated by using
- (a) `errno` and `sys_nerr`                      (b) `sys_errlist` and `sys_nerr`  
 (c) `sys_errlist` and `errno`                      (d) none of the above
130. A process that uses CPU, cannot continue to use it if
- (a) the CPU time slice expires                      (b) a higher priority process arrives  
 (c) it has to wait for an event to happen                      (d) it executes an `exit` statement



131. The command `cd ../../`
- (a) serves no purpose (b) is invalid  
(c) is equivalent to `cd ..` (d) none of the above
132. The UNIX tool `awk`
- (a) can do both numerical and string comparison  
(b) decides from the context whether the comparison is numerical or alphabetical  
(c) signals an error if an alphabet is compared with a number  
(d) all of the above
- \*133. Which of the following strings will be matched by `awk`, if `/(x+)*y!$/` is the specified pattern to be searched for?
- (a) `x+x+x+y!$` (b) `x x x x y!$`  
(c) `x x x xy!` (d) none of the above
134. When `awk` encounters strings in arithmetic expressions,
- (a) it treats them as having the value 0 (b) it treats them as having the value 1  
(c) it displays an error message (d) it is assigned an arbitrary value
135. Which of the following comments about `awk` are true?
- (a) It is a text processing language (b) Arrays can be indexed by string  
(c) It has features for redirecting its output (d) None of the above
- \*136. Which of the following UNIX tools, receives input only from the standard input?
- (a) `awk` (b) `grep` (c) `sed` (d) `tr`
137. If `x.c` is a file, then `ed x.c` creates a copy of `x.c` in
- (a) `/etc` (b) `/usr` (c) `/tmp` (d) `/usr/bin`
- \*138. The number of 3's in the output of the following C program
- ```
main()
{
    printf("1"); fork();
    printf("2"); fork();
    fork(); printf("3");
}
```
- is
- (a) 1 (b) 8 (c) 4 (d) 2
139. Which of the following processes has the PID 1?
- (a) kernel (b) unix (c) init (d) shell
140. Which of the following remarks about `fgrep` are true?
- (a) It is faster than `grep`.
(b) It is compact to use.
(c) It does not recognize any meta-character.
(d) It can simultaneously search for different patterns.

12. What are the potential problems when a DBMS executes multiple transactions concurrently?
- (a) The lost update problem (b) The dirty read problem
(c) The unrepeatable read problem (d) The phantom problem
13. The data flow model of an application mainly shows
- (a) the underlying data and the relationships among them
(b) processing requirements and the flow of data
(c) decision and control information
(d) communication network structure
14. Consider the set of relations given below and the SQL query that follows:
- Students: (Roll_number, Name, Date_of_birth)
Courses: (Course_number, Course_name, Instructor)
Grades: (Roll_number, Course_number, Grade)
- ```
SELECT DISTINCT Name
FROM Students, Courses, Grades
WHERE Students.Roll_number = Grades.Roll_number
AND Courses.Instructor = Korth
AND Courses.Course_number = Grades.Course_number
AND Grades.Grade = A
```
- Which of the following sets is computed by the above query?
- (a) Names of students who have got an A grade in all courses taught by Korth  
(b) Names of students who have got an A grade in all courses  
(c) Names of students who have got an A grade in at least one of the courses taught by Korth  
(d) None of the above
15. Which of the following desired features are beyond the capability of relational algebra?
- (a) Aggregate computation (b) Multiplication  
(c) Finding transitive closure (d) None of the above
16. In airline reservation system, the entities are date, flight number, place of departure, destination, type of plane and seats available. The primary key is
- (a) flight number (b) flight number + place of departure  
(c) flight number + date (d) flight number + destination
17. For a database relation  $R(a,b,c,d)$  where the domains of  $a,b,c$ , and  $d$  include only atomic values, only the following functional dependencies and those that can be inferred from them hold.
- $a \rightarrow c$   
 $b \rightarrow d$
- The relation is in
- (a) first normal form but not in second normal form  
(b) second normal form but not in third normal form  
(c) third normal form  
(d) none of the above

6. The column of a table is referred to as the

- (a) tuple (b) attribute (c) entity (d) degree

The next four questions are based on the following details. Consider the given schemes.

```
Branch_scheme = (Branch_name, assets, Branch_city)
Customer_scheme = (Customer_name, street, Customer_city)
Deposit_scheme = (Branch_name, account_number, Customer_name, balance)
Borrow_scheme = (Branch_name, loan_number, Customer_name, amount)
Client_scheme = (Customer_name, banker_name)
```

7. Using relational algebra, the query that finds customers who have a balance of over 1000 is

- (a)  $\pi_{\text{customer\_name}} (\sigma_{\text{balance} > 1000} (\text{Deposit}))$   
 (b)  $\sigma_{\text{customer\_name}} (\pi_{\text{balance} > 1000} (\text{Deposit}))$   
 (c)  $\pi_{\text{customer\_name}} (\sigma_{\text{balance} > 1000} (\text{Borrow}))$   
 (d)  $\sigma_{\text{customer\_name}} (\pi_{\text{balance} > 1000} (\text{Borrow}))$

8. Which of the following queries finds the clients of banker Agassi and the city they live in?

- (a)  $\pi_{\text{Client.Customer\_name.Customer\_City}} (\sigma_{\text{client.Customer\_name=Customer.Customer\_name}} (\sigma_{\text{Banker\_name='Agassi'}} (\text{Client} \times \text{Customer})))$   
 (b)  $\pi_{\text{Customer\_name.Customer\_City}} (\sigma_{\text{Banker\_name='Agassi'}} (\text{Client} \times \text{Customer}))$   
 (c)  $\pi_{\text{Client.Customer\_name.Customer\_City}} (\sigma_{\text{Banker\_name='Agassi'}} (\sigma_{\text{client.Customer\_name=Customer.Customer\_name}} (\text{Client} \times \text{Customer})))$   
 (d)  $\pi_{\text{Customer\_name.Customer\_City}} (\sigma_{\text{Banker\_name='Agassi'}} (\text{Client} \times \text{Customer}))$

9. Which of the following tuple relational calculus finds all customers who have a loan amount of more than 1200?

- (a)  $\{t \mid t(\text{Customer\_name}) \in \text{borrow} \wedge t[\text{amount}] > 1200\}$   
 (b)  $\{t \mid t(\text{Customer\_name}) \in \text{borrow} \wedge t[\text{amount}] > 1200\}$   
 (c)  $\{t \mid \exists s \in \text{borrow} (t[\text{Customer\_name}] = s[\text{Customer\_name}] \wedge s[\text{amount}] > 1200)\}$   
 (d) None of the above

10. Which of the following Domain relational calculus finds all customers who have a loan amount of over 1200?

- (a)  $\{ \langle c \rangle \mid \exists b, l, a (\langle b, l, c, a \rangle \in \text{borrow} \vee a > 1200) \}$   
 (b)  $\{ \langle c \rangle \mid \exists b, l, a (\langle b, l, c, a \rangle \in \text{borrow} \wedge a > 1200) \}$   
 (c)  $\{ \langle c \rangle \mid \exists \langle b, l, c, a \rangle \in \text{borrow} \wedge a > 1200 \}$   
 (d)  $\{ \langle c \rangle \mid \langle b, l, c, a \rangle \in \text{borrow} \wedge a > 1200 \}$

11. Given the functional dependencies

$X \rightarrow W; X \rightarrow Y; Y \rightarrow Z$  and  $Z \rightarrow PQ$

which of the following does not hold good?

- (a)  $X \rightarrow Z$  (b)  $W \rightarrow Z$  (c)  $X \rightarrow WY$  (d) None of the above

\*141. Which of the following results in an error?

- (a) `expr 4+5` (b) `expr 9-3` (c) `expr 2*3` (d) `expr 7/5`

142. Which of the following is not a command delimiter?

- (a) new line (b) ; (c) & (d) ,

143. A file abc has the following shell script in it.

```
cat $1 > $1.$$
```

The command `sh abc file1`

- (a) results in an error  
 (b) is equivalent to `cp $1 $1.$$`  
 (c) copies the contents of file1 to another file that has the PID of the executing shell as its extension  
 (d) none of the above

144. `*?*`  will be the output of

- (a) `echo *?*`  (b) `echo '*?*'` (c) `echo "**?*"` (d) `echo \*\*\*`

145. Which of the following shell variables can be used to customize the editors (like `ex`, `vi`)?

- (a) `PATH` (b) `IFS` (c) `HOME` (d) `EXINIT`

Go through the following sequence of commands and answer the next two questions based on it.

```
$echo $x
$sh
$x=hai
$export x
$sh
```

\*146. `echo $x` will output

- (a) `hai` (b) garbage  
 (c) an empty line (d) none of the above

\*147. If the command `exit` is run twice followed by running the command `echo $x`, the output will be

- (a) `hai` (b) garbage  
 (c) an empty line (d) none of the above

\*148. An orphan process

- (a) is a child process that was terminated before the parent process  
 (b) is adopted by the login shell  
 (c) is adopted by the process dispatcher  
 (d) will be denoted by the process status `O`

\*149. Which of the following calls never returns an error?

- (a) `getpid` (b) `fork` (c) `ioctl` (d) `open`

\*150. The following C program

```
main()
{
 fork(); fork(); printf("yes");
}
```

prints yes

- (a) only once      (b) twice      (c) 4 times      (d) 8 times

\*151. When a process makes a system call, its mode changes from

- (a) user to kernel  
 (b) kernel to user  
 (c) restricted to unrestricted  
 (d) unrestricted to restricted

\*152. Choose the correct statements.

- (a) When a process makes a system call, a context switch is initiated.  
 (b) Kernel is not involved in servicing a system call.  
 (c) When a process making a system call has to wait for an event to occur, then a process switch to the kernel process is initiated.  
 (d) System calls cannot be serviced in kernel mode.

\*153. The command `ls > xy`

- (a) displays an error message, if `xy` exists and is write protected  
 (b) if followed by `cat xy`, lists `xy` also  
 (c) redirects errors, if any, to `xy`  
 (d) none of the above

154. Shell functions

- (a) are another name for shell procedures      (b) execute faster than shell procedures  
 (c) are executed by a new shell      (d) are not executed by a new shell

\*155. The `cc` command makes a total of

- (a) 1 pass      (b) 2 passes      (c) 4 passes      (d) 5 passes

156. Which of the following is not invoked when the `cc` command executes?

- (a) `/lib/cpp`      (b) `/lib/cl`      (c) `/bin/as`      (d) `/bin/ld`

157. `creat` will fail, if

- (a) there are too many open files  
 (b) the filename is a directory  
 (c) the named file already exists with its write permission off  
 (d) the parent directory of the named file is write protected

158. Which of the following arguments to the open system call, will be discarded, if the named file already exists?

- (a) `O_TRUNC`      (b) `O_APPEND`      (c) `O_EXCL`      (d) `O_CREAT`

## Chapter 12

# Database Management Systems

1. Which normal form is considered adequate for relational database design?

- (a) 2 NF      (b) 3 NF      (c) 4 NF      (d) BCNF

2. The concept of locking can be used to solve the problem of

- (a) lost update      (b) uncommitted dependency  
 (c) inconsistent data      (d) deadlock

3. Given relations  $R(w,x)$  and  $S(y,z)$ , the result of

```
SELECT DISTINCT w, x
FROM R, S
```

is guaranteed to be same as  $R$ , if

- (a)  $R$  has no duplicates and  $S$  is non-empty  
 (b)  $R$  and  $S$  have no duplicates  
 (c)  $S$  has no duplicates and  $R$  is non-empty  
 (d)  $R$  and  $S$  have the same number of tuples

4. A functional dependency of the form  $X \rightarrow Y$  is trivial if

- (a)  $Y \subseteq X$       (b)  $Y \subset X$       (c)  $X \subseteq Y$       (d)  $X \subset Y$  and  $Y \subset X$

5. If every non-key attribute is functionally dependent on the primary key, then the relation will be in

- (a) first normal form      (b) second normal form  
 (c) third normal form      (d) fourth normal form



- Which of the following techniques is preferable for transferring large amount of data to and from a memory in a short time?
- (a) Programmed I/O (b) Interrupt-driven I/O  
(c) DMA (d) None of the above
- Privileged instructions can be executed
- (a) only in monitor mode (b) only in user mode  
(c) both in user and monitor mode (d) none of the above
- The first pass of a simple two-pass assembler
- (a) allocates spaces for the literals  
(b) computes the total length of the program  
(c) builds the symbol table for the symbols and their values  
(d) generates code for all the load and register instructions
- The ideal choice for interrupt oriented applications is
- (a) Z-80 (b) Motorola-6800 (c) 8085 (d) 8008
- Choose the correct statement.
- (a) Any software can be simulated by hardware.  
(b) Any hardware can be simulated by software.  
(c) Firmware is nothing but hardware implementation of software.  
(d) Firmware is nothing but software implementation of hardware.
- Which of the following is always true?
- (a) A compiled program uses more memory than an interpreted program.  
(b) A compiler converts a program to a lower level language for execution.  
(c) A compiler takes less memory than an interpreter.  
(d) Compiled programs take more time for execution than interpreted programs.
- In a two-pass assembler the object code generation is done during the
- (a) second pass (b) first pass  
(c) zeroeth pass (d) none of these
- In a two-pass assembler, adding literals to literal table and address resolution of local symbols are done during
- (a) first pass and second pass respectively (b) second pass  
(c) second pass and first pass respectively (d) first pass
- The data transfer rate of a double density floppy disk system is about
- (a) 5 Kbits/sec (b) 50 Kbits/sec (c) 500 Kbits/sec (d) 5000 Kbits/sec
- A linker is given object modules for a set of programs that were compiled separately. What information need not be included in an object module?
- (a) Object code  
(b) Relocation bits  
(c) Names and locations of all external symbols defined in the object module  
(d) Absolute addresses of internal symbols

159. Under which of the following circumstances `rm /y/x`, cannot remove `x`?
- (a) If `x` is write protected, but `y` is not write protected.  
(b) If `x` is not write protected, but `y` is write protected.  
(c) If `y` has its execution permission bit off.  
(d) All of the above.
160. File pointer
- (a) is a long integer  
(b) is of pointer data type  
(c) represents the position of the read-write head from the beginning of the file.  
(d) none of the above
- \*161. The C compiler can be modified to compile programs coded in other high level languages just by changing
- (a) `/lib/ccom` (b) `/lib/c2` (c) `/lib/c1` (d) `/bin/as`
162. When a file is aliased
- (a) a new directory entry is created (b) a new i-node is created  
(c) the i-node number is shared (d) none of the above
163. Setting the execute bit on has no meaning, if the file is a
- (a) directory (b) shell script (c) C source code (d) symbol table
164. Which of the following sections of an executable binary file has all uninitialised data items?
- (a) `bss` (b) `Data` (c) `Header` (d) `Symbol table`
165. In which section of a process, the information about the arguments to the program are available?
- (a) `Data` (b) `Text` (c) `Stack` (d) `User-block`
166. Which of the following system calls transforms an executable binary file into a process?
- (a) `fork` (b) `exec` (c) `ioctl` (d) `longjmp`
167. UNIX was first installed in
- (a) IBM-360 (b) PDP/11 (c) PDP/7 (d) CRAY
168. PID is used by the system to identify
- (a) a process (b) the file name (c) the i-node (d) all of the above
169. Choose the best answer.  
Suspended processes are written onto a
- (a) swap area (b) dedicated area (c) ROM (d) critical area
- \*170. Which of the following system calls, does not return control to the calling point, on termination?
- (a) `fork` (b) `exec` (c) `ioctl` (d) `longjmp`
- \*171. Which of the following remarks about the return value of "wait" are true?
- (a) In case of normal termination (through `exit`), the lower byte of the `wait` status is set to zeroes



- (b) In case of abnormal termination, the lower byte of the `wait` status is set to zeroes
- (c) A core dump sets the seventh bit on
- (d) A process in `zombie` status sets the seventh bit on

172. The following C program

```
main()
{
 printf("WHATIZIT");
 system("date");
}
```

- (a) first prints `WHATIZIT` and then displays the output of `date` command in the next line.
- (b) first prints `WHATIZIT` and then displays the output of `date` command in the same line.
- (c) first displays the output of `date` command and then `WHATIZIT` in the next line.
- (d) none of the above.

173. The program

```
main()
{
 printf("x");
 fflush(stdout);
 system("date");
}
```

- (a) gives the same output as the program

```
main()
{
 printf("x\n");
 system("date");
}
```

- (b) prints `x`, before displaying `date`
- (c) prints `x` after displaying `date`
- (d) all of the above

174. An attempt to read from a locked file, results in

- (a) prematured termination
- (b) a deadlock
- (c) an indefinite wait
- (d) none of the above

175. Which of the following is not a valid argument to the function `main` in a C program?

- (a) `errno`
- (b) `argc`
- (c) `envp`
- (d) `argv`

176. Mounting a file system results in the loading of

- (a) boot block
- (b) super block
- (c) i-node table
- (d) all of these

- (c) It is used to place the literals definition in a specified memory location that is given in the operand field.
- (d) It creates a literal pool that contains all the literal operands used since the previous `LTORG`.

26. Pick the machine independent phase(s) of the compiler.

- (a) Syntax analysis
- (b) Code generation
- (c) Lexical analysis
- (d) Intermediate code generation

27. Which of the following statement(s) about loading is/are true?

- (a) Modification records are used for specifying program relocation in relative addressing mode instructions.
- (b) Modification records are best suited for specifying program relocation in direct addressing and fixed instruction format.
- (c) Text record uses a relocation bit associated with each word of the object code in direct addressing and fixed instruction format.
- (d) Modification records are best suited for relative addressing mode

28. Pick the machine dependent operating system features.

- (a) Interrupt processing
- (b) File processing
- (c) Process scheduling
- (d) Job scheduling

29. Pick the machine independent operating system features.

- (a) I/O supervision
- (b) file processing
- (c) Management of real memory
- (d) Job scheduling

30. Pick the machine independent step(s) that can be used to optimize the memory requirement of a program.

- (a) Eliminating loop invariant computations
- (b) Code hoisting
- (c) Elimination of common sub-expressions
- (d) Register allocation strategies

31. What interrupt is generated when an attempt to divide by zero is made?

- (a) Supervisor call interrupt (SVC)
- (b) Program interrupt
- (c) I/O interrupt
- (d) Timer interrupt

32. Pick the class of interrupt with highest priority.

- (a) Supervisor call interrupt (SVC)
- (b) Program interrupt
- (c) I/O interrupt
- (d) Timer interrupt

33. Pick the class of interrupt with lowest priority.

- (a) Supervisor call interrupt (SVC)
- (b) Program interrupt
- (c) I/O interrupt
- (d) Timer interrupt

34. The delay between job submission and job completion is called

- (a) turnaround time
- (b) in-process time
- (c) response time
- (d) waiting time

6. When exceptional situation occurs outside the CPU the H/W signal given is  
 (a) reset (b) interrupt (c) hold (d) wait
7. The root directory of a disk should be placed  
 (a) at a fixed address in main memory (b) at a fixed location on the disk  
 (c) anywhere on the disk (d) at a fixed location on the system disk
8. Efficient use of addressing modes  
 (a) speeds up execution (b) reduces the number of instructions  
 (c) reduces the size of instructions (d) none of the above
9. The correct sequence of time delays that happen during a data transfer from a disk to memory is  
 (a) seek time, latency time and transfer time  
 (b) seek time, access time and transfer time  
 (c) latency time, seek time and transfer time  
 (d) latency time, access time and transfer time
10. Writing a software in assembly language is preferred to writing in a high level language when  
 (a) memory space is limited  
 (b) optimal use of the hardware resources available is of primary concern  
 (c) programmer's productivity is important  
 (d) portability is important
11. Which of the following addressing modes support Indexing?  
 (a) Relative (b) Memory indirect (c) Immediate (d) Direct
12. Which of the following are the advantages of 2's complement over 1's complement?  
 (a) Easy to implement using digital components  
 (b) Subtraction can be done by a single addition  
 (c) It has only one zero  
 (d) All of the above
13. Pick the functions that are completely performed in pass 1.  
 (a) Processing of DB pseudo-op (b) Updating the location counter  
 (c) Processing of EQU pseudo-op (d) Processing of DS pseudo-op
14. Pick the functions that are performed in pass 2.  
 (a) Creating the proper address mode using the base table.  
 (b) Updating the location counter  
 (c) Processing of EQU pseudo-op  
 (d) Generation of object code using machine operation table
15. Pick the correct statement(s) about LTOrg.  
 (a) It is a pseudo-op.  
 (b) It is used to load the object program at some specified memory location that is given in the operand field.

\*177. Choose the correct statements.

- (a) If two users execute a file, two copies will be there in memory  
 (b) Shareable programs are loaded into swap area  
 (c) `chmod u+t filename`, is a valid command  
 (d) None of the above

\*178. Go through the following C program

```
main()
{
 int i, n;
 for(i = 1 ; i <= n ; ++i)
 fork();
 printf("yes");
}
```

For what value of n, will yes be printed 24 times?

- (a) 3 (b) 4  
 (c) 5 (d) Impossible to find such an n

\*179. Consider the following program

```
main()
{
 printf("God looks at the heart, not the hand\n");
 system("date");
 printf("The giver, not the gift");
}
```

If a.out is the executable file corresponding to the above program, then the command `a.out > x ; cat x`

- (a) displays both the messages, with the output of `date` coming in between  
 (b) displays the output of `date` before both the messages  
 (c) does not display the first message  
 (d) none of the above

\*180. The following program

```
main()
{
 if(fork() > 0)
 sleep(100);
}
```

results in the creation of

- (a) an orphan process (b) a zombie process  
 (c) a process that executes for ever (d) none of the above

181. In UNIX, the status of a process may be  
 (a) running (b) orphan (c) sleeping (d) zombie

182. Consider the following program

```
main()
{
 int i = 7;
 if(0 == fork())
 i += 10;
 else
 {
 wait(0);
 printf("%d", i);
 }
}
```

Choose the correct answers.

- (a) The statement `i += 10` is executed by the child only  
 (b) The statement `i += 10` is executed by the parent only  
 (c) The child can start executing, only after the termination of the parent process.  
 (d) None of the above
- \*183. The value of `i`, printed by the above program will be  
 (a) 10 (b) 7 (c) 17 (d) none of the above
- \*184. The exception to the fact that any process in UNIX, has a parent is  
 (a) `dev` (b) `sh` (c) `kernel` (d) `login`
185. Which of the following are shared between a parent process and a child process?  
 (a) External variables (b) Pointer variables  
 (c) File pointers (d) Pipes

- \*186. Consider the following C program

```
main()
{
 int j = 7, *i = &j;
 if(0 == fork())
 *i = (*i + 10);
 else
 {
 wait(0);
 printf("%d", *i);
 }
}
```

6. Choose the true statements about the linkage loaders.  
 (a) The input to it consists of a set of object programs that are to be linked together.  
 (b) The main data structure needed for linking is an external symbol table.  
 (c) Pass 1 assigns addresses to all external symbols.  
 (d) Pass 2 performs loading, relocating and linking.
7. Which of the following statements about the macro-processors are incorrect?  
 (a) The general features such as macro expansion, use of keyword parameters are machine dependent.  
 (b) Macro invocation includes the name of the macro being called and the arguments to be used.  
 (c) Macro definition is also referred to as macro call.  
 (d) Macros cannot be nested.
8. Transfer of information to and from the main memory takes place in terms of  
 (a) bits (b) bytes (c) words (d) nibbles
- \*9. The output of the lexical analyzer is  
 (a) a set of regular expressions (b) syntax tree  
 (c) set of tokens (d) string of characters
- \*10. An interpreter is preferred over a compiler  
 (a) when efficient use of computer resources is the consideration  
 (b) during program development phase  
 (c) when storage space is to be minimized  
 (d) all of the above
- \*11. A compiler-compiler is a/an  
 (a) compiler which compiles a compiler program  
 (b) software tool used in automatic generation of a compiler  
 (c) compiler written in the same language it compiles  
 (d) another name for cross-compiler
12. A compiler which allows only the modified section of the source code to be recompiled is called as  
 (a) incremental compiler (b) reconfigurable compiler  
 (c) dynamic compiler (d) selective compiler
13. Which of the following system software resides in main memory always?  
 (a) Text editor (b) Assembler (c) Linker (d) Loader
14. In a two-pass assembler the pseudo-code `EQU` is to be evaluated during  
 (a) pass 1 (b) pass 2  
 (c) not evaluated by the assembler (d) none of the above
15. Effective address got by index mode will be the same as that of register indirect mode when the index register has the value  
 (a) 0 (b) 1 (c) -1 (d) can never be the same

# Chapter 11

## System Software

1. Which of the following is/are not assembler directive(s)?  
(a) START (b) LOAD (c) END (d) BYTE
2. Which of the following remarks about the assembler are true?  
(a) It translates mnemonic instruction into machine code.  
(b) The instruction formats, addressing modes, etc., are of direct concern in assembler design.  
(c) Design of an assembler is independent of the source language.  
(d) Both (b) and (c) are correct.
- \*3. A programming language is to be designed to run on a machine that does not have a big memory. The language should  
(a) prefer a two-pass compiler to an one-pass compiler  
(b) prefer an one-pass compiler to a two-pass compiler  
(c) prefer an interpreter to a compiler  
(d) not support recursion
4. Which of the following about the loader is/are incorrect?  
(a) Loader brings object program into memory for execution.  
(b) Linkage editors perform linking after loading.  
(c) Dynamic linking schemes delay linking until execution time.  
(d) Absolute loader modifies the object program so that it can be loaded at any address location.
5. Two procedures both of which treat the other as a called procedure and itself the callee, are called as  
(a) master-slave routines (b) sub-sub-routines  
(c) co-routines (d) ambiguous master-slave routines

- The value of *i* that will be printed is  
(a) 10 (b) 7 (c) 17 (d) none of the above
- \*187. In the previous question, if the declarations are made global (i.e., declared before `main()`), then the value of *i* that is printed will be  
(a) 10 (b) 7 (c) 17 (d) none of the above
188. Choose the correct statements.  
(a) Interrupts are caused by events that are external to a process.  
(b) An exception condition is caused by an event external to a process.  
(c) An exception condition happens in the middle of the execution of an instruction.  
(d) An interrupt happens in the middle of the execution of an instruction.
- \*189. Consider the following program
- ```
#include<signal.h>
mn() ;
main()
{
    signal(SIGINT, mn);
    for (; ; ) ;
}
mn()
{
    printf("x\n");
}
```
- On receipt of the signal SIGINT
(a) the default action corresponding to SIGINT will be performed
(b) the user defined function `mn`, will be executed
(c) what happens depends on whether the signal is received for the first time or not
(d) none of the above
- *190. In the previous question, if the statement `signal(SIGINT, mn);` is repeated thrice, then
(a) what happens depends on whether the signal is received for the first time or not.
(b) what happens depends on whether the signal is received for the fourth time or not.
(c) it cannot print the message more than three times
(d) none of the above
- *191. Which of the following comments about semaphore are true?
(a) It is an integer that can act as a counter
(b) Its value depends on the number of resources to be shared
(c) Its value is stored in the kernel
(d) It can be used for resource synchronization

192. The following sequence of commands

```
grep x *.c > mn&
wc -l mn&
rm mn&
```

produces the same result as the single command

- (a) `grep x *.c | wc -l`
- (b) `wc -l < grep x *.c`
- (c) `grep x *.c > wc -l`
- (d) none of the above

193. Choose the correct statements.

- (a) Kernel is non-preemptive.
- (b) Interrupts are blocked when critical section of a code is being executed.
- (c) No process can put another process to sleep.
- (d) None of the above.

194. Choose the correct statements.

- (a) A disk cannot have more than one file system stored in it.
- (b) On the logical level, the kernel deals with disks rather than file system.
- (c) The logical to physical device address mapping is done by the device driver.
- (d) None of the above.

195. Which of the following data structures is not maintained by the kernel?

- (a) User file descriptor table
- (b) File table
- (c) I-node table
- (d) None of the above

196. Choose the correct statements.

- (a) A file has only one associated i-node.
- (b) I-node stands for index node.
- (c) A particular i-node may correspond to more than one file.
- (d) A file can have more than one associated i-node.

197. The call `pipe(p)` is valid if `p` had been declared as

- (a) `int p`
- (b) `int p[2]`
- (c) `char *p`
- (d) `FILE *p`

198. Choose the correct statements.

- (a) When a program terminates, pipes are automatically closed.
- (b) If the write end of a pipe is closed then an attempted read from the other end results in a deadlock.
- (c) If the write end of a pipe is closed, then an attempted read from the other end, terminates the program.
- (d) None of the above.

- 61. (X, Y) in the transformed co-ordinate system corresponds to $(x/3, y/4)$ of the old system. So the given ellipse transforms to $X^2 + Y^2 = 1$.
- 62. The equation of the line joining $(-1, 0)$ and $(4, 5)$ is $x - y + 1 = 0$. This cuts the window boundaries $x = 0$ and $y = 3$ at the points $(0, 1)$ and $(2, 3)$ respectively.
- 63. A point (x, y) will be inside the window, if $0 < x < 5$ and $0 < y < 3$. So, the points $(1, 1)$ and $(4, 2)$, both lie within the window. So, it is already clipped.
- 64. This line cuts the x-axis at $(-2, 0)$ and y-axis at $(0, 4)$. So, it lies totally outside the window and so cannot be clipped.
- 71. The equation of the line joining V and A is given by $x = t+3; y = t+6; z = 4-t$. Since B and C satisfy this, all the four points are collinear. We can find that $t = 0$ for A , $t = -1$ for B , $t = -2$ for V and $t = -3$ for C . From these values it is clear that these points lie in the order C, V, B, A . Hence the answer.

7. If the equation of the curve is unaltered, if x is replaced by y and y by x , then the curve will be symmetric about the line $x = y$.
11. Standard equation of a parabola is $y^2 = 4ax$. Put $x = at^2$ and solve for y .
12. x - increment = $x_2 - x_1 / \max((x_2 - x_1), (y_2 - y_1))$
 y - increment = $y_2 - y_1 / \max((x_2 - x_1), (y_2 - y_1))$
13. $y = x^2 + (k - 1)x + 9 = (x + (k - 1)/2)^2 - ((k - 1)/2)^2 + 9$
 For the entire graph to lie above the x -axis, y should be greater than 0, for all x .
 So, $9 - ((k - 1)/2)^2 > 0$. i.e., $(k - 7)(k + 5) < 0$ or $-5 < k < 7$
15. $x_{(\text{view port})} = (XV_{\text{max}} - XV_{\text{min}})(XW - XW_{\text{min}}) / (XW_{\text{max}} - XW_{\text{min}}) + XV_{\text{min}}$
 $Y_{(\text{view port})} = (YV_{\text{max}} - YV_{\text{min}})(YW - YW_{\text{min}}) / (YW_{\text{max}} - YW_{\text{min}}) + YV_{\text{min}}$
16. ADDRESS(x, y) = ADDRESS(0, 0) + $y((x - \text{max}) + 1) + x$
24. (a) and (c) are even functions, because $f(x) = f(-x)$. (b) is neither even nor odd as $f(x) \neq f(-x)$ and $-f(x) \neq f(-x)$
28. For (a), solving the equation $f(x + T) = f(x)$, we get $T = 1$ as the period. (b) is periodic with period π . (c) and (d) are not periodic.
34. If (0, 0) is substituted in the equation, we get 0, which is less than 2. So, any point on the same side as that of the origin, should yield a value less than 2, when substituted in the equation. Hence the result.

35. The determinant $\begin{vmatrix} i & j & k \\ a & b & c \\ 1 & 3 & 1 \end{vmatrix} = (2, 1, 6)$

- gives the three equations, $b - 3c = 2$; $c - a = 1$; $3a - b = 6$. This system of equations, has no solution as using the second equation in the third gives $b - 3c = -3$, which contradicts the first.
36. Check by multiplying the corresponding transformation matrices. Also refer Qn.25.
38. A function $F(x, y) \rightarrow (a, b)$ is linear if $F(ax, ay) = aF(x, y)$ and $F(a+x, b+y) = F(a, b) + F(x, y)$. The functions given in options (a), (c), (d) satisfy these two conditions but option (b) doesn't.
52. Storing without any type of coding, needs $15 \times 15 = 225$ units of memory. Using run-length coding, the first row needs 4 units, each of the rows from 2 to 6 needs 6 units and the rest of the rows (from 7 to 15) needs 2 units each. So, totally $4 + 6 \times 5 + 2 \times 9 = 52$ units. The compression achieved is $52/225$, which is roughly $1/9$.
56. Let it be scaled in Y-axis with a factor k . The equation of the circle $x^2 + y^2 = a^2$, after scaling becomes $x^2 + (ky)^2 = a^2$. This can be written as $x^2/a^2 + y^2/(a/k)^2 = 1$. This is an ellipse.
57. Length of arc = Length of radius \times angle subtended in radians.
58. The three given points form a triangle. This triangle will have a circum-circle that touches all the three points.
59. Since the circle with centre at the origin, is symmetric about the X-axis, Y-axis, the line $X = Y$ and the line $X = -Y$, the reflection of (2, 4) about these axes, will also be points on the circle.

*199. Consider the following program

```
#include<signal.h>
main()
{
    signal(SIGINT, mn);
    fork();
    fork();
    for(;;);
}
mn()
{
    printf("x\n");
}
```

Choose the correct statements.

Pressing the key

- (a) sends the signal, only to the parent process
 (b) sends the signal, to all the four processes
 (c) for the first time, prints x only once
 (d) for the first time, prints x four times

*200. Consider the following program

```
main()
{
    int p[2];
    pipe (p);
    fork();
}
```

Choose the correct statements.

- (a) The pipe will be recognized only by the parent process.
 (b) $p[0]$ is the file descriptor of the write end of the pipe.
 (c) There will be four file descriptors in memory.
 (d) The pipe will be shared by both the parent and the child processes.

Answers

- | | | | | |
|-------------|-------|---------------|----------|-------------|
| 1. a | 2. b | 3. a, b, c, d | 4. c | 5. a, c, d |
| 6. c | 7. b | 8. d | 9. c | 10. a, b, c |
| 11. a, b, d | 12. d | 13. b, c, d | 14. a, d | 15. a, c |
| 16. d | 17. c | 18. d | 19. a, c | 20. b |

- | | | | | |
|-----------------|-----------------|----------------|--------------|-----------------|
| 21. b | 22. a | 23. c | 24. c | 25. b |
| 26. d | 27. a, c | 28. a, c | 29. a, c | 30. a, b |
| 31. b, c | 32. b, c, d | 33. d | 34. a | 35. c |
| 36. c, d | 37. b, c | 38. a | 39. b | 40. a, b |
| 41. b, c | 42. a, b | 43. a | 44. c | 45. a, b, c, d |
| 46. d | 47. b | 48. a, c | 49. d | 50. b |
| 51. a | 52. a | 53. a, c | 54. a, b, c | 55. a, b, c |
| 56. a, b, c | 57. a | 58. a, b, c, d | 59. c | 60. c |
| 61. a, b, c | 62. b | 63. c | 64. b | 65. a, b, c |
| 66. a | 67. a | 68. a, b, d | 69. a, c | 70. b, c |
| 71. d | 72. a, b, c, d | 73. d | 74. b, c | 75. a, b, c, d |
| 76. a, b | 77. b | 78. a, c, d | 79. a, b, c | 80. a, b, c, d |
| 81. a, b, c | 82. b, c | 83. a, b, c, d | 84. c | 85. c |
| 86. a, b, c, d | 87. a, b | 88. c | 89. d | 90. b, c |
| 91. d | 92. a, c, d | 93. a, d | 94. a, c | 95. a, b, c |
| 96. a, c | 97. b, c | 98. c | 99. c | 100. b, c |
| 101. d | 102. c | 103. d | 104. b | 105. a |
| 106. d | 107. b | 108. c, d | 109. c | 110. c |
| 111. c | 112. a, b, c | 113. d | 114. c | 115. b, d |
| 116. a, b, c, d | 117. c | 118. a, b | 119. a, b | 120. b |
| 121. b | 122. c, d | 123. c | 124. a | 125. d |
| 126. c, d | 127. b, c | 128. a | 129. c | 130. a, b, c, d |
| 131. c | 132. a, b | 133. d | 134. a | 135. a, b, c |
| 136. d | 137. c | 138. b | 139. c | 140. b, c, d |
| 141. c | 142. d | 143. b, c | 144. b, c, d | 145. d |
| 146. a | 147. c | 148. a, c, d | 149. a | 150. c |
| 151. a, c | 152. a, b, c | 153. a, b | 154. b, d | 155. d |
| 156. b | 157. a, b, c, d | 158. d | 159. b, c | 160. a, c |
| 161. a | 162. a, c | 163. c | 164. a | 165. c |
| 166. b | 167. c | 168. a | 169. a | 170. b |
| 171. a, c, d | 172. c | 173. b | 174. d | 175. a |
| 176. b, c | 177. a, b, c | 178. d | 179. b | 180. b |
| 181. a, b, c, d | 182. a | 183. b | 184. c | 185. c, d |
| 186. b | 187. b | 188. a, c | 189. c | 190. a |
| 191. a, b, c, d | 192. d | 193. a, b, c | 194. c | 195. d |
| 196. a, b, c | 197. b | 198. a, c | 199. b, d | 200. c, d |

53. If the eccentricity of a conic is less than one then it is a
 (a) circle (b) parabola (c) ellipse (d) hyperbola
54. Parabola can be got from a right circular cone, by cutting it through a plane that is
 (a) parallel to the side of the cone (b) perpendicular to the axis of the cone
 (c) a tangent to the cone (d) parallel to the axis of the cone
55. Fractals deal with curves that are
 (a) irregularly irregular (b) regularly irregular
 (c) irregularly regular (d) regularly regular
- *56. A circle, if scaled in only one dimension becomes a/an
 (a) parabola (b) hyperbola (c) ellipse (d) remains a circle
- *57. Let R be the radius of a circle. The angle subtended by an arc of length R at the centre of the circle is
 (a) 1 degree (b) 1 radian
 (c) 45 degrees (d) impossible to determine
- *58. Choose the correct statement.
 Given three non-collinear points,
 (a) it is always possible to draw a circle passing through the three points.
 (b) it may or may not be possible to draw a circle passing through the three points.
 (c) it is impossible to draw a circle passing through the three points
 (d) none of the above
- *59. (2,4) is a point on a circle that has centre at the origin. Which of the following point(s) is/are also on the circle?
 (a) (2, -4) (b) (-2, 4) (c) (4, -2) (d) (-4, 2)
60. Aspect ratio is generally defined as the ratio of the
 (a) vertical to horizontal points
 (b) horizontal to vertical points
 (c) vertical to (horizontal + vertical) points
 (d) either (a) or (b), depending on the convention followed
- *61. Let $F: R^2 \rightarrow R^2$ be the mapping defined by $F(x, y) = (x/3, y/4)$. The image under F of the ellipse $x^2/9 + y^2/16 = 1$, is
 (a) the circle $x^2 + y^2 = 1$ (b) the line $x/3 + y/4 = 1$
 (c) the ellipse $x^2/27 + y^2/64 = 1$ (d) none of the above

The next three questions are based on this window.

A rectangle is bound by the lines $x = 0$; $y = 0$; $x = 5$ and $y = 3$.

- *62. The line segment joining (-1, 0) and (4, 5), if clipped against this window will connect the points
 (a) (0, 1) and (3, 3) (b) (0, 1) and (2, 3)
 (c) (0, 1) and (4, 5) (d) none of the above

- *36. Which of the following transformations are non-commutative?
 (a) Linear followed by scaling (b) Linear followed by rotation
 (c) Scaling followed by rotation (d) None of the above
37. Reflection of a point about x-axis, followed by a counter-clockwise rotation of 90° , is equivalent to reflection about the line
 (a) $x = -y$ (b) $y = -x$ (c) $x = y$ (d) $x + y = 1$
- *38. Which one of the following is not a linear transformation?
 (a) $F : R^3 \rightarrow R^2$ defined by $f(x, y, z) = (x, z)$
 (b) $F : R^3 \rightarrow R^3$ defined by $f(x, y, z) = (x, y - 1, z)$
 (c) $F : R^2 \rightarrow R^2$ defined by $f(x, y) = (2x, y - x)$
 (d) $F : R^2 \rightarrow R^2$ defined by $f(x, y) = (y, x)$
39. Raster systems display a picture from a definition in a
 (a) display file program (b) frame buffer
 (c) display controller (d) none of the above
40. Back face removal is an example of
 (a) object space method (b) image space method
 (c) combination of both (d) none of the above
41. A bilinear transformation can be simulated by the transformations
 (a) translation, rotation and stretching (b) translation and rotation
 (c) rotation, stretching and inversion (d) rotation, stretching, inversion and translation
42. Choose the correct answers.
 To construct the rectangle $ABCD$, it is enough if
 (a) the length and breadth are given
 (b) the vertices A and B are given
 (c) the vertex A and the length of the diagonal are given
 (d) the vertices A and C are given
43. A raster colour display processor supports a resolution of 1024×800 with upto 16 million colours simultaneously displayable. What will be the approximate size (in bytes) of the frame buffer used in the display processor?
 (a) 1.2×10^6 (b) 2.4×10^6 (c) 16×10^6 (d) 10^5
44. A Bezier cubic curve with control points P_0, P_1, P_2, P_3 is defined by the equation
- $$f(u) = \sum_{i=0}^3 P_i B_i^3(u)$$
- B_2^3 is
 (a) $(1-u)^3$ (b) u^3 (c) $3u(1-u)^2$ (d) $3u^2(1-u)$
45. Choose the incorrect statement from the following about the basic ray tracing technique used in image synthesis.
 (a) In this technique, rays are cast from the eye point through every pixel on the screen.
 (b) In this technique, viewing transformations are not applied to the scene prior to rendering.

Explanations

6. Process is a program in execution. However, if many users are simultaneously executing the same program, the system has to differentiate the instances of the program, in use. Hence the best answer is (c).
7. Refer question 6.
9. `/dev/tty` is a synonym for the terminal you are currently using. If `echo welcome > /dev/tty`, is a part of a shell, `welcome` will be echoed in the terminal in which the script is run, doesn't matter which terminal it is.
10. `/dev/null` can be called UNIX built-in dust-bin. To prevent a program from filling the monitor with garbage, `/dev/null` comes in handy. Just redirect it to `/dev/null`. It gladly accepts garbage. It is a universal sink.
12. We can use the command `chmod 711 noname`, followed by `chmod u+s noname` (use `ls -l noname` and check). Else use the single command `chmod 4711 noname`. What is this "s" anyway? Only the super user has the permission to change `/etc/passwd` file. But any user can update it through the `passwd (/bin/passwd)` command. If you type `ls -l /bin/passwd` you can see the user execution bit set to `s` instead of `x`. It is because of this "s", a user can access `/etc/passwd` through the `passwd` command, for which he is not otherwise entitled to.
13. Refer to Question 12.
16. `argv[0]` is a pointer to the command (here `a.out`) and `argv[1]` to the first argument. So, `argv[1][2]`, refers to the third (since count begins at 0) character of the first argument which is `d`.
17. `argv++`, makes `argv[0]` point to the first argument. So, after `argv++`, `argv[0]` will be pointing to `God` and `argv[1]` to `loves`. So, `argv[1][2]` will be `v`.
18. `strchr()` is the correct function. It returns a pointer to the last occurrence of the character specified as argument.
21. When a process executes a system command-like system("date"), it forks a child process, waits for it to execute the `date` command and terminates. This can be implemented by the child making the call
- ```
execl("/bin/date", "date", (chr *)0)
```
24. The redirection symbol `>`, puts everything that will otherwise be displayed in the screen, to the named file (`y` here). If `x.c` is syntactically correct, then the command `cc x.c`, silently creates `a.out`, but what comes to the screen is nothing (other than the next prompt). So, `y` will be empty.
31. When you create a file using an editor, it will be assigned default permission setting (determined by the `umask` value). Generally the execute permission will be off. So, to run a shell script, set its execute bit on. However, if you run `sh x`, `x` will be executed, even if its execute bit is off.
40. `passwd - /etc/passwd` and `/bin/passwd`  
`bin - usr/bin` and `/bin`



46. The sort combines the output of who ('-' stands for output of the previous command) and contents of file1, and sorts the resultant. So, `who | sort - file1 > file2` is equivalent to the sequence of commands `who > x, cat x file1 > y, sort y > file2`. Hence the correct answer is (d).
47. The time command uses `stderr`, instead of `stdout` to display its results. As a result of this, what is redirected to `x` is just the output of `sort filename` command and not the time details. The time details will be displayed in the screen, since screen by default is the `stderr`.
51. Any command that is keyed-in will be first processed by the shell, which divides the command into tokens, taking into account the metacharacters. So, `a b` will be divided into two tokens `a` and `b`. But `'a b'` or `"a b"` will pass `a b` as such (i.e. as one token). So, `argv[2]` will be `'a b'` and `argv[3]`, `"c d"`. Hence the answer.
53. `lint` can throw light on many things, which the compiler generally overlooks. So, potential errors can be spotted and the program debugged, even before compilation. Hence the answer is (a) & (c).
59. `SCCS` stands for Source Code Control System. Many applications need periodical updation of files (e.g., master file in a business application). It is always better to have backup of the changed version, for security reasons and undo operations. `SCCS` is a UNIX tool that can be used to keep history of the changes made.
50. Any shell script will not be executed by the current shell. The current shell forks a new shell that executes the named shell script and terminates after it. So, any variable exported in the shell script will not be recognized by the parent shell. The `.` (dot) command makes the named shell script to be executed by the current shell. On the negative side, `.` (dot) commands (like, `profile`) don't accept command line arguments.
51. `cpp` is 'C' preprocessor, `m4` is a general purpose macro processor that can be used to preprocess C, as well as assembly language programs. Unlike `cpp`, it can do integer arithmetic, some string and substring manipulation, in addition to file inclusion and conditional macro expansion which can be done by `cpp` also.
52. Suppose you enter a command like `cp x y`. Unlike the user, who uses the name to identify and differentiate files, the system uses i-node number to uniquely identify a file. Any file name has an associated i-node number. In UNIX, different files can have the same name. But the associated i-node number will be different. The filename—i-node correspondence can be found in the directory which has to be the first one that is to be searched, as nothing can be done to a file without knowing its i-node number.
54. Directory entries have two fields. One for the file name and the other for the i-node number. The i-node has many fields for storing all the information about the file, except the file name and the actual content of the file. The content of the file will be in a separate place. So, the details of any file will be spread over these three places. When a file is updated its name and i-node number will remain the same. Only the contents and some fields in the i-node (like file size, time of last access, etc.) need to be changed. Hence the answer.
56. The `mv` command, say, `mv x y` is not going to change the file content, the i-node number or other information in the i-node. Only the file name is going to change. The file name is present only in the directory. So, the answer is (a).

- (c) by copying each row of the block into a column in the new frame buffer location  
(d) none of the above
27. In the clipping algorithm of Cohen & Sutherland using region codes, a line is already clipped if the,
- (a) codes of the end points are the same.  
(b) logical AND of the end points code is not 0000.  
(c) logical OR of the end points code is 0000.  
(d) logical AND of the end points code is 0000.
- \*28. Choose the functions that are periodic.
- (a)  $f(x) = x - [x]$ ; where  $[x]$  stands for the greatest integer  $\leq x$   
(b)  $f(x) = 1 \cos(x) 1$   
(c)  $f(x) = (x) \cos(x)$   
(d)  $f(x) = \sin(1/x)$ , if  $x \neq 0$ ; 0 otherwise
29. In Sutherland-Hodgman algorithm for polygon clipping, assume  $P$  (present point) lies inside the window and  $S$  (previous point) lies outside the window. Then, while processing through that window boundary, we should
- (a) store the intersection point of line  $PS$  ( $S'$ ) only  
(b) store the points  $P$  and  $S'$   
(c) store the point  $P$  only  
(d) store the points  $S$  and  $S'$
30. Random-scan monitors are also referred to as
- (a) vector display (b) stroke writing display  
(c) calligraphic display (d) none of the above
31. The refresh rate below which a picture flickers is
- (a) 25 (b) 30 (c) 35 (d) 60
32. Pixel phasing is a technique for
- (a) shading (b) anti-aliasing  
(c) hidden line removal (d) none of the above
33. When several types of output devices are available in a graphic installation, it is convenient to use
- (a) bundled attributes (b) unbundled attributes  
(c) inquiry attributes (d) none of the above
- \*34. Which of the following points lies on the same side as the origin, with reference to the line  $3x + 7y = 2$ ?
- (a) (3, 0) (b) (1, 0) (c) (0.5, 0.5) (d) (0.5, 0)
- \*35. If  $(a, b, c) \times (1, 3, 1) = (2, 1, 6)$ , where  $\times$  denotes the vector product, then  $(a, b, c)$  is given by
- (a) (0, 1, 1) (b)  $(k, 0, 1 - k)$  for any real  $k$ .  
(c)  $(-1, 2, -7)$  (d) there exists no solution

Oblique projection with an angle of  $45^\circ$  to the horizontal plane is called as

- (a) cabinet projection (b) isometric projection  
(c) cavalier projection (d) none of the above

Which of the following curves are symmetric about the line  $x = y$ ?

- (a)  $1 + x + y = 0$  (b)  $y = |x|$  (c)  $y = x^3$  (d)  $|x| + |y| = 9$

Choose the correct statement(s).

- (a) Random-scan monitors draw a picture one line at a time.  
(b) The components line of a random-scan picture must be refreshed in a particular order.  
(c) Raster-scan monitors draw a picture one line at a time.  
(d) Random-scan method is well suited for displaying shading and colour areas.

The perspective anomaly in which the object behind the centre of projection is projected upside down and backward onto the viewplane is called as

- (a) perspective foreshortening (b) vanishing view  
(c) view confusion (d) topological distortion

Which statement about beam penetration method for producing colour display is/are true?

- (a) It is used with raster-scan monitors.  
(b) It is used with random-scan monitors.  
(c) By using beam penetration method a wide range of colours can be obtained.  
(d) It uses three electron guns, one each for green, blue and red colours.

$x = at^2$ ;  $y = 2at$ , is the parametric equation of a

- (a) circle (b) rectangular hyperbola  
(c) parabola (d) ellipse

A line connecting the points (1, 1) and (5, 3) is to be drawn, using the DDA algorithm. Find the value of  $x$  and  $y$  increments.

- (a)  $x$ -increment = 1;  $y$ -increment = 1 (b)  $x$ -increment = 0.5;  $y$ -increment = 1  
(c)  $x$ -increment = 1;  $y$ -increment = 0.5 (d) none of the above

The entire graph of the function  $f(x) = x^2 + kx - x + 9$  is strictly above the  $x$ -axis if and only if

- (a)  $-3 < k < 5$  (b)  $-3 < k < 2$  (c)  $-3 < k < 7$  (d)  $-5 < k < 7$

The phenomenon of having a continuous glow of a beam on the screen even after it is removed is called as

- (a) fluorescence (b) persistence (c) phosphorescence (d) incandescence

Perform window to viewport transformation for the point (20, 15).

Assume that  $(X_{wmin}, Y_{wmin})$  is (0, 0);  $(X_{wmax}, Y_{wmax})$  is (100, 100);  $(X_{vmin}, Y_{vmin})$  is (5, 5);  $(X_{vmax}, Y_{vmax})$  is (20, 20). The value of  $x$  and  $y$  in viewport is

- (a)  $x = 4$ ,  $y = 4$  (b)  $x = 3$ ,  $y = 3$   
(c)  $x = 8$ ,  $y = 7.25$  (d)  $x = 3$ ,  $y = 4$

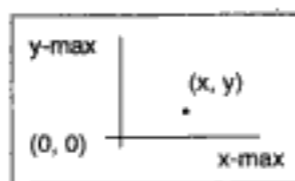

Fig. 10.1

68. For regular (ordinary) files the first character (i.e. `b` here), will be just a underscore. For directories `d`, for character special files '`c`' and '`b`' for a block read special file. The last column will have `lp` for line printer, `hp` for disk drives, `tty` for terminals etc. The `3` in `3, 0` denotes the major device number and `0` - minor device number. That is, this system denotes tape drives by `3` and `0` to single out a particular tape drive from the many tape drives, the system may have.

70. First, the i-node number corresponding to `/dev/tty` (i.e. the terminal currently used) is procured. Then the i-node is accessed. From it, the system understands, it is a character special file. So, whatever you type, if followed by '`\n`' will be echoed in the terminal. Typing control `d`, also flushes the buffer contents to `tty`. But unlike '`\n`', control `d` is not transmitted. So, if you type `ab(^d)cd(^d)` first `ab` will be immediately transmitted, then `cd` will be transmitted. Whenever you press control `d`, then what you have typed between the previous control `d` (or from the start of the current line) to the current control `d` will be transmitted. So, if you type two control `d` consecutively or a single control `d`, at the beginning of a line then you are telling it to transmit, but nothing is there to be transmitted. So, the command gets terminated.

81. The purpose of `lex` is to generate a 'C' function `yylex`, that will recognize any pattern that is given as input to `lex`, as a regular expression. Also, it can perform the specified action (like deleting, printing, changing to some other pattern, enciphering, etc.) when the specified pattern is matched. It does this by converting regular expression into a non deterministic finite state automata - then a finite state automata—then reduces the number of states in it. `lex` is a program generator, which means we can write our own code, which functions the same as the `lex` output. Since `lex` applies a general set of rules to achieve this, what it generates will not make efficient use of memory and is slower too. Yet it is a powerful tool, that simplifies the programmer's job.

84. Two mistakes. First is the `?`. It is a meta character. So, when the shell encounters `?`, it will try for a match, with the files in the current directory, made up of just one character. Use `\?`, to suppress the special meaning of `?`. `$answer` means the value of the variable `answer`. Since you are reading the value of the variable `answer`, it should be read `answer`.

88. File descriptors of `stdin`, `stdout`, `stderr` are 0, 1 and 2 respectively. `2>&1`, instructs the shell to merge the stream `stderr` with `stdout`. `1>&2`, merges `stdout` with `stderr`. This instruction is valid only for that line in the shell script. Also, if you use redirection in the command line itself, the `>&` takes precedence, if it contradicts.

89. There is a facility that allows shell scripts to take input from its own contents, e.g., `grep $1<<tillhere`, used in a shell script file `x`. Input to `grep` is that part of `x`, from the first character to the first occurrence of `tillhere` (in the beginning of the line). If `tillhere` is never encountered as the first word, the entire file `x`, will be taken as input.

90. `cc x.c; a.out-` means execute the command `cc x.c` and then `a.out`. If `x.c` fails to compile successfully, then if there is any executable file `a.out`, it will be executed. So, execution of `a.out`, has nothing to do with the outcome of `cc x.c`. In the case of `cc x.c && a.out`, `a.out` will be executed only if `x.c` compiles successfully (i.e. returns 0 as the exit status).



- 100. \* is a metacharacter that matches with any file in the current directory, other than those starting with a . (dot). ?x can't be a file name. If you try to create such a file, say with vi ?x command, ? will be interpreted as a metacharacter, and so expanded by shell, if matched.
- 102. stdin is a pointer to the standard input file (i.e. keyboard by default) which is available to any program in open mode. So, getc(stdin) is syntactically correct and means reading from a keyboard which is what getchar() does. In fact getc() is implemented as a macro (rather than as a function).
- 105. All the library i/o functions (like getchar, scanf, gets etc.) use the same intermediate buffer and share the same file pointer. So, they can be interleaved in any order to access consecutive characters in a file without causing any inconsistency. Unlike them, system calls (like read and write) directly manipulate the file. So, mixing system calls and library function will have undesired consequence.
- 106. The close statement closes the file, whose file descriptor is 1, i.e., stdout. So, printf will fail. So, the program immediately terminates.
- 108. return statement when executed transfers control back to the calling environment. So, if a subroutine executes a return statement control comes back to the main routine. exit always terminates the program, which means within the main routine, exit and return can be used interchangeably.
- 116. Kernel should be involved anyway. /etc/init, which has to initiate all processes, forks and executes /etc/getty. It is /etc/getty that displays the login prompt. When one responds to the login prompt, the /bin/login replaces getty. Ultimately, the login shell replaces the login process.
- 117. read needs three arguments. The first argument should be a file descriptor fd. The standard input, stdin has the fd value 0. The second argument should be a pointer to character, which is buff by our assumption. The third argument is the number of bytes to be read. So it is read(0, buff, 1).
- 129. Any error has an integer code associated with it. The external variables errno (integer), sys\_errlist (array of strings), sys\_nerr, are available to any C program. Any error sets errno to the associated integer code and sys\_errlist[errno] gives the associated message. This way perror () can be simulated by using errno and sys\_errlist. sys\_nerr gives the total number of error messages available in sys\_errlist.
- 133. (x +), means x followed by one or more number of blanks, '\*' is a metacharacter which means the occurrence of 0 (i.e., not occurring even once) or any number of times of the proceeding pattern. So, (x +)\* means the pattern x +, can occur 0 or any number of times. (x +)\*y!-means the pattern (x +)\* immediately followed by a 'y' and '!'. '\$' is a metacharacter, which means at the end of the line. So, choice (a) is wrong. So, (x +)\*y!\$, means (x +)\*y! at the end of the line (i.e. last part of the line). Hence the answer is (d).
- 136. tr, unlike the other three, cannot access a named file for input. So, to make it access a file, say x, we have to use the redirection operator <. i.e. tr (action field) < x.
- 138. When a process executes a fork() statement, a duplicate process is created and both the processes execute all the statements following the fork() statement. So, the parent process

Chapter **10**

# Computer Graphics

- 1. The point (4, 1) undergoes the following 3 transformations successively.
  - I. Reflection about the line  $y = x$
  - II. Translation through a distance of 2 units along the positive x-axis
  - III. Rotation through an angle of  $\pi/4$  about the origin in the counter clockwise direction.
 The final position of the point will be
  - (a)  $(-1/\sqrt{2}, 7/\sqrt{2})$
  - (b) (1, 4)
  - (c)  $(3/\sqrt{2}, -5/\sqrt{2})$
  - (d)  $(3/\sqrt{2}, 5/\sqrt{2})$
- 2. Let the maximum number of pixels in a line be  $M$ . The number of subdivisions at most necessary using the mid-point subdivision method of clipping is
  - (a)  $N = \log_2 M$
  - (b)  $N = 2^M$
  - (c)  $n = 2 M$
  - (d) none of the above
- 3. Find the incorrect statement(s).
  - (a) A perspective projection produces realistic views.
  - (b) A parallel projection preserves realistic dimensions.
  - (c) A perspective projection preserves realistic dimensions.
  - (d) A parallel projection gives realistic representation of 3-D objects.
- \*4. The people of the planet Mars designed a scale for measuring the temperature in which water freezes at 100 units and boils at 250 units. The people of Jupiter designed a scale in which water freezes at 75 units and boils at 300 units. A temperature of 200 units in Mars will measure \_\_\_\_\_ in Jupiter.
  - (a) 300
  - (b) 225
  - (c) 250
  - (d) 175
- \*5. The two scales coincide at
  - (a) 130
  - (b) 165
  - (c) 150
  - (d) 170

93. In the best case quick sort algorithm makes  $n \log(n)$  comparisons. So  $1000 \times \log(1000) = 9000$  comparisons, which takes 100 sec. To sort 100 names a minimum of  $100 (\log 100) = 600$  comparisons are needed. This takes  $100 \times 600/9000 = 6.7$  sec.
94. For sorting 200 names bubble sort makes  $200 \times 199/2 = 19900$  comparisons. The time needed for 1 comparison is 200 sec (approximately). In 800 sec it can make 80,000 comparisons. We have to find  $n$ , such that  $n(n-1)/2 = 80,000$ . Solving,  $n$  is approximately 400.
95. Let the first element be the pivot element always. The best way is the one that splits the list into two equal parts each time. This is possible if the pivot element is the median. Consider the given set of names or the equivalent set 1, 2, 3, 4, 5, 6, 7. Four is the median and hence should be the pivot element. Since the first element is the pivot element, 4 should be the first element. After the first pass, 4 will be put in the correct place and we are left with two sub lists 1, 2, 3 and 5, 6, 7. Since 2 is the median of 1, 2, 3 the list should be rearranged as 2, 1, 3 or 2, 3, 1. For similar reasons 5, 6, 7 should be rearranged as 6, 5, 7 or 6, 7, 5.
96. Immediately after visiting a node, append it to the queue. After visiting all its children, the node currently in the head of the queue is deleted. This process is recursively carried out on the current head of the queue, till the queue becomes empty.
99. The corresponding expression is  $-(-a-b)+e!$ . This is 1 if  $a=-b$  and  $e$  is either 1 or 0, since  $1! = 0! = 1$ .
100. Probability for the first record not colliding is  $x/x$ .  
Probability for the second record not colliding is  $x-1/x$ .  
(This is because one place is already occupied. So, favorable number of cases is  $x-1$ ).  
Probability for the third record not colliding is  $x-2/x$ .  
Probability for the  $(m-1)^{\text{th}}$  record not colliding is  $x-(m-2)/x$ .  
Now the next  $(m^{\text{th}})$  record is resulting in a collision. Out of the  $x$  places, it should hash to one of the  $(m-1)$  places already, filled. So probability is  $(m-1)/x$ . The required probability is  $(x/x)(x-1/x)(x-2/x) \dots (x-(m-2)/x)(m-1/x)$
110. In a regular graph, all the vertices will be of the same degree. Total degrees of all the vertices is  $nd$ . Each edge will be increasing the total degree by 2. So, totally  $nd/2$  edges.
112. It can be proved by induction that any 3-ary tree with  $n$  internal nodes will have exactly  $2(n-1)+3$  leaf nodes. In this question  $n$  is 6.
116. The tree for option (d) is:

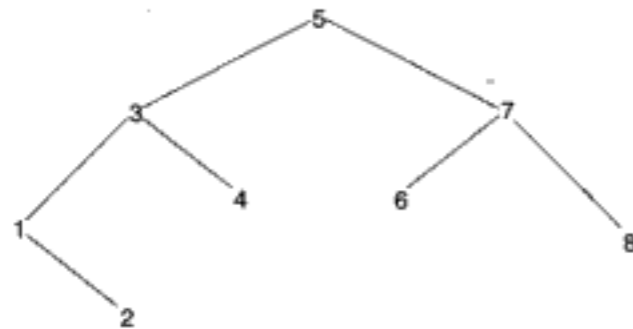

For the other options it is impossible to construct a binary search tree having the listed preorder.

- when it executes the first `fork()` statement creates a duplicate process. So, we have two processes both of which, will execute the statements `printf("2"); fork(); fork(); printf("3");` So 2 will be printed twice. The next `fork()` call will produce a total of four processes (since it will be executed by the two existing processes each of which creates a duplicate process). So, the last `fork()` call, will produce eight processes, all executing `printf("3")`. Hence, 3 will be printed 8 times. Hence the correct answer is (b).
141. `expr` is a shell command that evaluates the arithmetic expression, given as argument to it. The multiplication symbol `*`, will be treated as a metacharacter by the shell. So, `2*3`, will not be interpreted as multiplying 2 and 3. The shell will expand it to include all the files in the current directory, starting with 2 and ending with 3. So, the correct answer is (c).
146. If a shell variable, say `x` is undefined, `echo $x` will display an empty line (this is the case, if `x` is set to a null string also). `$sh`, results in the current shell, forking a child shell and waiting for it to terminate. So, `x=hai`, will be executed only by the child shell and hence will not be recognized by the parent shell. As a result of the next command `$export x`, `x` will be passed to any shell forked by the child shell. The next command `$sh`, results in the child shell forking another shell (let us call it as the grand-child shell) and waiting for it to terminate. So, `echo $x` will be executed by the grand-child shell, which has inherited `x` and its value from the child shell because of the `export` command used. So, `echo $x` will display `hai`.
147. Execution of the command `exit`, results in the immediate termination of the current shell. In such a case, control will go to its parent shell. So, using `exit` twice, takes us back to the shell that displayed an empty line for `echo $x`. So, `echo $x` if run after two `exit` will display an empty line. So, the answer is (c).
148. When a process executes a `fork()` statement the duplicate process that is created survives as a separate and independent process. Because of the CPU time slice, either of the two may terminate first. If the parent terminates first, the forked process will be immediately adopted by the process dispatcher. If you run the `ps -al` command, this is reflected by a `O` in the status column.
149. Any call has to be made by some process. Any process will have an identity number. `getpid()`, returns this number. So, it can never fail. Hence the result.
150. Refer Question 138.  
Execution of the first `fork()`, results in a total of two processes. The next `fork()`, makes it four. All the four processes, execute the statement `printf("yes");` So, `yes` will be printed four times.
151. Any process starts executing in user mode. If a system call is made (by executing a special machine instruction), the mode changes from user to kernel. Then the process executing in kernel (unrestricted) mode, services the call. After servicing, another context switch puts it back to the user mode. The hardware views a process by its mode (not by its PID).
152. Kernel is not a separate process that runs along with other processes. It is a part and parcel of other user processes. That is why we say system calls are serviced by a process executing in kernel mode. The kernel, as such, is not at all involved in servicing the system call. When a process making a system call has to wait for an event to happen, then first a context switch



transforms the process from user to kernel mode. Then a process switch is initiated that switches control to the kernel process. After that event occurs, again a process switch followed by a context switch, puts the process back in the user mode and the execution is continued.

- 153. Before listing, it opens the file `xy` in the current directory. So, `cat xy` will display `xy` also. If `xy` already exists, its contents will be discarded and a new `xy` is created. However, if `xy` already exists and is `write` protected, an error message will be displayed on the screen.
- 155. `cc` command first invokes the C preprocessor `/lib/cpp`. The output will be redirected to `/lib/ccom` and `/lib/c2`. Then the assembler `/bin/as` is invoked. Finally the linking/loader `ld` will be called. So, a total of five passes. Only `/lib/ccom` is actually 'C' language dependent.
- 161. Refer Qn. 155.
- 170. A `fork` call duplicates any process that executes it. But the `exec` family of calls, overlays the address space of the process that executed it. So, no chance of getting back to it.
- 171. The `wait()` function takes an argument that is a pointer to an integer. It fills the two lower order bytes of the integer that is pointed to, by its argument, with some information. A normal termination sets the lowest byte to zero and the other byte is filled with an integer that equals the `exit` status of the process, for which it was waiting. In case of abnormal termination, the second lowest byte is filled with zeroes and the lowest byte filled with an integer that reflects the cause of the abnormality (e.g. signal number). In case of a core dump or a zombie process, the seventh bit is set on.
- 172. Two things should happen before one sees a message on the screen. First, there should be a program that writes that message to a buffer. Secondly, the contents of the buffer should be sent to the screen. The buffer is necessary to balance the speed mismatch among different communicating devices. This program will put `WHATIZIT` in the buffer. Transfer from buffer to the terminal takes place if the buffer is full or `'\n'` is present in the message or `fflush(stdout)` is used explicitly. Since none of these cases applies to this case, it will not be transferred. So, the command `date` will be executed and displayed in the screen. Then the process terminates. But before termination, the buffer contents will be flushed out to the screen by default. So, `WHATIZIT` will be displayed, but after the output of the `date` command.
- 173. Refer Qn. 172.  
The commands (like `date`), automatically feed `'\n'` on termination. So the given program prints `x` and output for `date` in the same line. So `a` is wrong. Hence the answer is (b).
- 174. `read()` does not check, whether the file is locked or not. So it successfully reads from a locked file. Same is the case with `write()`.
- 175. The function `main` can take up the three arguments. They are `argc` - an integer that gives the number of arguments, `argv` - an array of pointer to character, that gives the arguments, and `envp` - an array of pointer to character, that gives all the variables defined in the environment.
- 177. Each user executing the same executable file will be using a copy of it. This is a pure overhead, if the executable code is shareable (like `ed`, `vi`, etc.). By setting, what is called as

- 64. If there is only one record, then the probability of a collision will be  $1/100$ . If 2, then  $2/100$  etc., If 9 then  $9/100$ . So, the required probability is  $1 + 2 + 3 \dots 9/100 = 0.45$ .
- 69. If the (1, 3) entry in  $M^3$  is 2, it means there are 2 paths of length 3, connecting nodes 1 and 3. If you see the graph in option (a), there are 2 paths connecting 1 and 3, ( $1 \rightarrow 2 \rightarrow 3 \rightarrow 3$  and  $1 \rightarrow 3 \rightarrow 3 \rightarrow 3$ ).
- 70. In breadth first traversal the nodes are searched level by level. Starting with vertex A, the only next choice is B. Then C, then 1 and lastly 2. Comparing with `ABCDE`, option (a) is the correct answer.
- 71. In the depth first traversal, we go as deep as possible before we backtrack and look for alternate branches. Here it yields `ABC21`. So, labels of nodes 1 and 2 should be E and D respectively.
- 73. In topological sorting we have to list out all the nodes in such a way that whenever there is an edge connecting  $i$  and  $j$ ,  $i$  should precede  $j$  in the listing. For some graphs, this is not at all possible, for some this can be done in more than one way. Option (d) is the only correct answer for this question.
- 74. Strong component of a given graph is the maximal set of vertices such that for any two vertices  $i, j$  in the set, there is a path connecting  $i$  to  $j$ . Obviously vertex 'd' can't be in the maximal set (as no vertex can be reached starting from vertex  $d$ ). The correct answer is option (d).
- 75. Use Prim's algorithm or Kruskal's algorithm and verify the result.
- 78. Each comparison will append one item to the existing merge list. In the worst case one needs  $m + n - 1$  comparisons which is of order  $m+n$ .
- 79. It can be proved by induction that a strictly binary tree with 'n' leaf nodes will have a total of  $2n - 1$  nodes. So, number of non-leaf nodes is  $(2n-1)-n = n-1$ .
- 82. Recursive programs take more time than the equivalent non-recursive version and so not efficient. This is because of the function call overhead.  
In binary search, since every time the current list is probed at the middle, random access is preferred. Since linked list does not support random access, binary search implemented this way is inefficient.
- 83. The 5 binary trees are

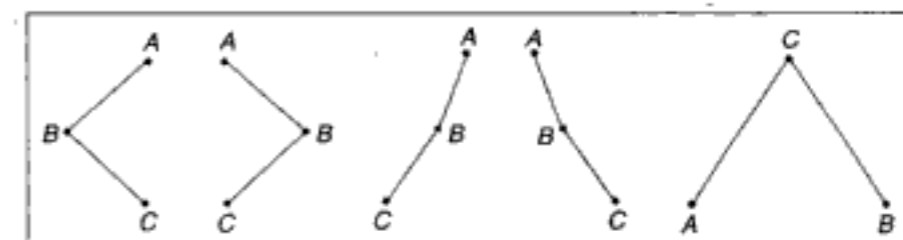

Fig. 9.16

- 92. Blocking factor is the number of logical records that is packed to one physical record. Here in every 3 inch, there should be 2 inch of information. Hence  $2 \times 10 = 20$  logical records.

Cost of minimum path from 3 to 5 is 4

Cost of minimum path from 4 to 5 is 7

Since the maximum is 7, eccentricity of node 5 is 7.

50. Refer Qn.49.

Find eccentricity of all nodes.

Eccentricity of node 1 is  $\infty$

Eccentricity of node 2 is 6

Eccentricity of node 3 is 8

Eccentricity of node 4 is 5

Eccentricity of node 5 is 7

Center of a graph is the node with minimum eccentricity.

52. Total number of possible permutations for the previous problem is 5. For the four entries  $a, b, c, d$  the possibilities are  $a$ , followed by permutations of  $a, b, c$  which is 5.  $b$ , followed by permutations of  $a, c, d$ , which is 5. The other possibilities are  $c, b, a, d$ ;  $c, d, b, a$ ;  $c, b, d, a$ ;  $d, c, b, a$ . Totally 14.

56. Conventional way needs a storage of  $m \times n$ .

In the case of linked list implementation of sparse matrices, storage needed will be  $m + 3 \times$  (the number of non-zero entries).

Only in case (c), both the methods need the same storage of 30.

59. The tree whose preorder traversal yields  $* + A B - C D$ , is given in Fig. 9.15. Write the post-order traversal of the tree. That is the post-fix form.

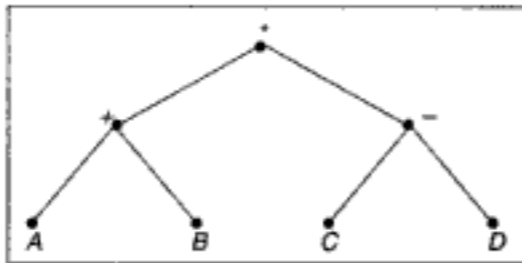

Fig. 9.15

60. Let there be ' $n$ ' items to be searched, After the first search the list is divided into two, each of length  $n/2$ . After the next search, 2 lists, each of length  $n/4$  and so on. This successive division has to stop when the length of list becomes 1. Let it happen after  $k$  steps. After the  $k$  steps,  $n/2^k = 1$ . Solving,  $n = 2^k$ . Hence the order is  $\log(n)$ .

61. Load factor is the ratio of number of records that are currently present and the total number of records that can be present. If the load factor is less, free space will be more. This means probability of collision is less. So, the search time will be less.

62. If the new record hashes onto one of the six locations 7, 8, 9, 10, 1 or 2, the location 2 will receive the new record. The probability is 6/10 (as 10 is the total possible number of locations).

63. You can verify that the 1st, 3rd, 5th, 7th...probes check at location 5.

The 2nd, 6th, 10th...probes check at location 8.

The 4th, 8th, 12th...probes check at location 4.

The rest of the address space will never be probed.

the sticky bit on, the executable code can be shared. In such a case, the file will be loaded into a special area called swap area. The sticky bit can be set by the command

```
chmod u+t <filename>
```

178. Each `fork` call creates a duplicate process. So if  $n$  is 1, `fork` will be called only once. So two processes will be executing `printf("yes")`. So, `yes` will be printed twice. If  $n=2$ , four processes and hence 4 "yes" will be printed. If  $n=3$  then 8 yes, 4 then 16, 5 then 32, which means 24 "yes" is impossible.

179. Refer Qn. 172

Transfer from buffer to a terminal, usually happens on a line by line basis. This is called line buffering. That's why a '`\n`' forced a buffer flushing. But redirection to a file involves block buffering. Only a full buffer or program termination or `fflush()` will initiate the transfer from buffer to the named file. So, when the system command is executed, the current contents of the buffer (i.e., the first message) will not be transferred. On termination, the contents of the buffer, which has both the messages will be flushed out to the file.

180. `fork` returns 0 to the child process and a non-zero integer (i.e. the PID of the created child) to the parent. Hence the child process will immediately get terminated as it has nothing to execute. But the parent process will be active for at least 100 seconds (because of `sleep(100)`). Though the child terminates before the parent, the corresponding entry in the process table will not be removed till the termination of the parent process. For this reason it is called a zombie process.

183. Though the parent process has to wait for the termination of the child process (because of the `wait()` statement), the value updated by the child will not be recognized by the parent. So, it prints 7.

184. The booting process loads `/unix` (i.e. kernel) into memory by some firmware and software operations. All other processes will be descendants of the process `/etc/init` which is created by the kernel exclusively for that purpose.

186. Refer to Qn. 183.

Even a pointer variable, which is used to change a value, by the child process, will not be recognized by the parent (& vice-versa). Anyway, the statement `printf("%d%d", &j, &i)` will produce identical output by both the processes, which implies that they use the same address space (of course at different times)

187. Even a global variable will not be shared.

189. `signal(SIGINT, mn)` is an instruction to execute the user defined function `mn` (instead of the default function), on receipt of the signal `SIGINT`. However, a second `SIGINT` will execute the default function.

190. Repeating the statement thrice, or any number of times, is equivalent to having only one statement, in essence. So the second `SIGINT` signal, will execute the default code.

191. Since its value has to be used by different processes, it is kept in the kernel.

192. The `ampersand`, runs the command as a background process. So, the three commands run as separate processes, each competing individually for CPU time slice. If they need more than one CPU time slice, the commands will overlap in their execution (with respect to time). So, unpredictable things can happen. For example, the first process creates the file `mn`.

Before termination if CPU switches over to the second process, then `wc` will act on file `mn`, whose data is not full. So, choice `a` is incorrect. Choices `b` and `c` are syntactically incorrect, as redirection can be done only to a file and not a command like `wc -l`. Hence the answer is `d`.

199. Refer Questions 189 and 190.

The two `fork` calls will result in a total of four processes, all of which execute `mn()` on the receipt of signal `SIGINT`. So, the signal, if received (by pressing the `<del>` key), will be sent to all the four processes. So, four "x" will be printed. One more `SIGINT` will do the default action of terminating the process.

200. The `read` and `write` ends of the pipe will be passed on to the child process. So, there will be four file descriptors in memory, albeit, a pair being duplicated. As a result of this duplication, one process may close one end, while the other may use the same as an open end.

apply the operator on the popped out entries and push the result onto the stack. If we follow this, we can find configuration in option (d) is not possible.

39. Merge-sort combines two given sorted lists into one sorted list. For this problem let the final sorted order be `-a, b, c, d`. The two lists (of length two each) should fall into one of the following 3 categories.

- (i) `a, b` and `c, d`
- (ii) `a, c` and `b, d`
- (iii) `a, d` and `b, c`

The number of comparisons needed in each case will be 2,3,3. So, average number of comparisons will be  $(2 + 3 + 3)/3 = 8/3$

Here is a better way of doing:

Let list `L1` have the items `a,c` and `L2` have the items `b,d`.

The tree drawn below, depicts the different possible cases. (`a&b` means `a` is compared with `b`. If `a` is smaller, the edge will be labeled `a`. The number within a circle, beside the leaf nodes, is the number of comparisons, needed to reach it.)

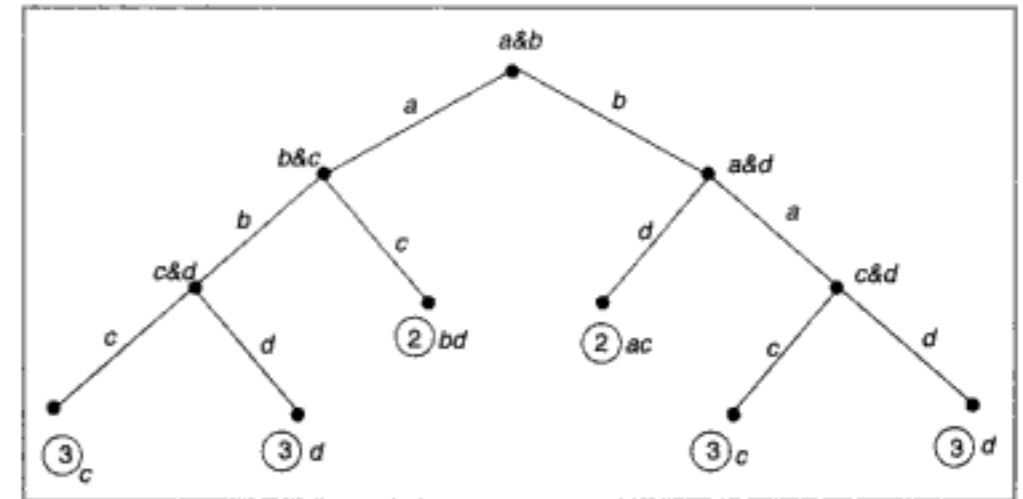

Fig. 9.14

From the tree, we find there are 6 possible ways. Total number of comparisons needed is  $3+3+2+2+3+3 = 16$ . So, average number of comparisons is  $16/6 = 8/3$ .

- 43. The maximum number of comparison is number of items  $\times$  radix  $\times$  number of digits i.e.,  $7 \times 10 \times 4 = 280$ ,
- 47. Dijkstra's algorithm solves single source shortest path problem.  
Warshall's algorithm finds transitive closure of a given graph.  
Prim's algorithm constructs a minimum cost spanning tree for a given weighted graph.
- 48. Third row corresponds to node 3. From 3 to 1, there is no path, So, the entry (3,1) should be zero. Since there is a path from 3 to 2 and also from 3 to 3 (i.e.,  $3 \rightarrow 2 \rightarrow 3$ ), the third row should be 0,1,1.
- 49. Eccentricity of a given node is the maximum of minimum path from other nodes to the given node.  
Cost of minimum path from 1 to 5 is 7  
Cost of minimum path from 2 to 5 is 6

19. Refer Qn. 18. Since each file is referenced with equal frequency and each record in a particular file can be referenced with equal frequency, average access time will be  $(25+(50+40)+(50+80+50)+...)/6 = 268$  (approximately).
20. By definition of order, there exists constants  $c_1, c_2, n_1, n_2$  such that  
 $T(n) \leq c_1 \times f(n)$ , for all  $n \geq n_1$ .  
 $T(n) \leq c_2 \times g(n)$ , for all  $n \geq n_2$ .
- Let  $N = \max(n_1, n_2)$  and  $C = \max(c_1, c_2)$ . So,  
 $T(n) \leq C \times f(n)$  for all  $n \geq N$   
 $T(n) \leq C \times g(n)$  for all  $n \geq N$
- Adding  $T(n) \leq C/2 \times (f(n) + g(n))$
- Without loss of generality, let  $\max(f(n), g(n)) = f(n)$ .  
 So,  $T(n) \leq C/2 (f(n) + f(n)) \leq C \times f(n)$ .  
 So, order is  $f(n)$ , which is  $\max(f(n), g(n))$ , by our assumption.
22. By recursively applying the relation we finally arrive at  
 $T(n-1) = c(n-1) + T(1) = c(n-1) + d$
- So, order is  $n$ .
24. The five possible trees are

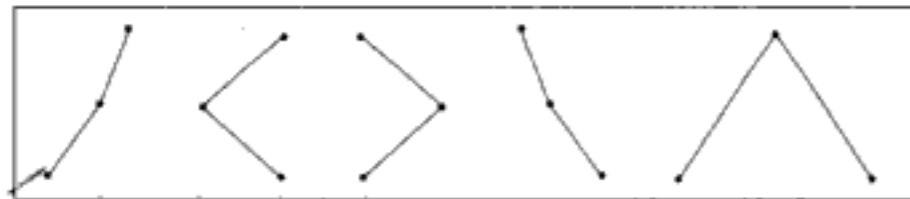

Fig. 9.13

25. Eight possible trees of depth 3. Six possible trees of depth 2. Altogether 14.
30. Using Hoffman's algorithm, code for a is 1111; b is 0; c is 110; d is 1110; e is 10.  
 Average code length  
 is  $4 \times 1.2 + 1 \times 0.4 + 3 \times 1.5 + 4 \times 0.8 + 2 \times 2.5 = 2.15$
32. Let us find what is  $T(4), T(5), T(6)$ .  
 $T(4) = T(3) + T(2) - T(1) = 3 + 2 - 1 = 4$   
 $T(5) = T(4) + T(3) - T(2) = 4 + 3 - 2 = 5$   
 $T(6) = T(5) + T(4) - T(3) = 5 + 4 - 3 = 6$
- By induction it can be proved that  $T(n) = n$ . Hence order is  $n$ .
33. Refer Qn.32. Let  $T(1) = T(2) = T(3) = k$  (say). Then  $T(4) = k + k - k = k$   
 $T(5) = k + k - k = k$ .
- By mathematical induction it can be proved that  $T(n) = k$ , a constant.
35. In the worst case it has to check all the  $2^n$  possible input combinations, which is exponential.
36. The postfix equivalent is  $2\ 3\ * \ 4\ 5\ + \ -$ . For evaluating this using stack, starting from the left, we have to scan one by one. If it is an operand push. If it is an operator, pop it twice.

## Chapter 3

# Principles of Programming Languages

1. If the postfix equivalent of the statement  
 if c then x else y is  $cxy\#$ , then the postfix form  $am+n-mn-ab-\#ba-\#$
- (a) has no syntactically valid prefix equivalent  
 (b) is equivalent to, if a then  $m+n$  then if  $m-n$  else  $a-b$  else  $b-a$   
 (c) is equivalent to, if a then if  $m+n$  then  $m-n$  then  $a-b$  else  $b-a$   
 (d) is equivalent to, if a then  $m-n$  else if  $m+n$  then  $a-b$  else  $b-a$
2. A recursive function  $f$ , is defined as follows:  
 $f(n) = 2$ , if  $n = 0$   
 $= m$ , if  $n = 1$   
 $= 2 \times f(n-1) + 4 \times f(n-2)$ , if  $n \geq 2$
- If the value of  $f(4)$  is 88, then the value of  $m$  is  
 (a) -1 (b) 0 (c) 2 (d) 1
- \*3. Consider the FORTRAN statement -  $DO\ 5\ I = 1, 10$   
 To recognize DO as a keyword, the compiler (lexical analyzer) has to scan  
 (a) 5 characters beyond O (b) 3 characters beyond O  
 (c) no character beyond O (d) 8 characters beyond O
4. Use of recursion  
 (a) enhances logical clarity (b) makes debugging easier  
 (c) reduces execution time (d) reduces code size



- \*5. A program has 100 instructions and another program (for the same problem) has 200 instructions. Which of the following comment logically follows?
- The execution time of the second program is more than that of the first.
  - The execution time of the second program is same as that of the first.
  - Compilation time of the second program, is more than that of the first.
  - None of the above.
6. The conditional expansion facility of macro processors is provided to
- test a condition during the execution of the expanded program
  - expand certain model statements depending upon the value of a condition during the execution of the expanded program
  - implement recursion
  - expand certain model statements depending upon the value of a condition during the execution of the macro expansion
- \*7. Which of the following languages is case-sensitive (i.e., IF is not same as if)?
- FORTRAN
  - BASIC
  - C
  - None of the above
- \*8. Val is a well known
- real-time language
  - object-oriented language
  - command language
  - data-flow language
9. Consider the following pseudo-Pascal function
- ```
function fibo (n : integer) : integer;
begin
  if(n = 0)      then fibo := 0
  else if(n = 1) then fibo := 1
  else fibo := fibo(n-1)+fibo(n-2)
end
```
- If fibo(5) is the function call, fibo(1) will be used
- 3 times
 - 4 times
 - 5 times
 - 6 times
- *10. An ordinary calculator treats all operators
- to be of equal precedence and associating to the right
 - to be of equal precedence and associating to the left
 - to be of unequal precedence and associating to the left
 - in the usual mathematical sense
11. In which of the following parameter passing mechanisms, the actual argument has to be a variable?
- Pass by value
 - Pass by result
 - Pass by value-result
 - Pass by reference
12. Which of the following class of statements usually produce no object code when compiled?
- Assignment
 - Declaration
 - Unreachable
 - Control

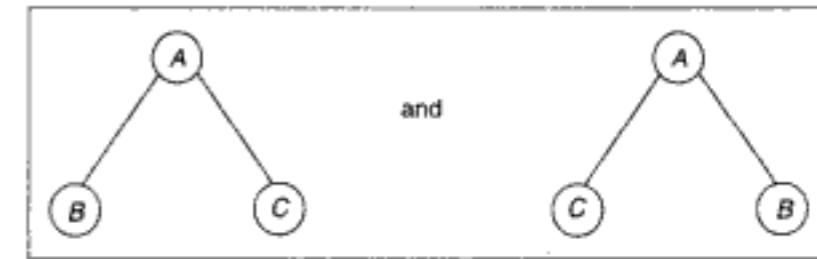

Fig. 9.11

This gives us 6 more possibilities.

6. Each comparison puts one element in the final sorted array. In the worst case $m+n-1$ comparisons are necessary.
8. It will be one more than the size of the biggest cluster (which is 4) in this case. This is because, assume a search key hashing onto bin 8. By linear probing the next location for searching is bin 9. Then 0, then 1. If all these resulted in a miss, we try at bin 2 and stop as it is vacant. This logic may not work if deletion operation is done before the search.
9. A strictly binary tree with 'n' leaves must have $(2n-1)$ nodes. Verify for some small 'n'. This can be proved by the principle of mathematical induction.
10. If the depth is d, the number of nodes n will be $2^{(d+1)}-1$.
So, $n+1 = 2^{(d+1)}$ or $d = \log(n+1) - 1$
12. For example, consider the binary search tree given in Qn.2. The inorder listing will be 1, 4, 5, 6, 10, 11, 12, 30, i.e. the numbers arranged in ascending order.
13. The 10 items i_1, i_2, \dots, i_{10} may be arranged in a binary search tree as in Fig. 9.12. To reach i_5 , the number of comparison needed is 1; for i_2 , it is 2; for i_8 it is 2; for i_1 it is 3, and so on. The average is $(1+(2+2)+(3+3+3+3)+(4+4+4))/10$, i.e., 2.9.
14. $f(37) = 37 \bmod 7 = 2$. So, 37 will be put in location 2. $f(38) = 3$. So, 38 will be in third location. $f(72) = 2$. This results in a collision. With linear probing as the collision resolving strategy, the alternate location for 72 will be the location 4 (i.e. next vacant slot in the current configuration). Continuing this way, the final configuration will be 98, 56, 37, 38, 72, 11, 48.
15. If the search key matches the very first item, with one comparison we can terminate. If it is second, two comparisons, etc. So, average is $(1+2+\dots+n)/n$, i.e., $(n+1)/2$
17. Let $m > n$. Let m/n yield a quotient x and remainder y. So, $m = n*x+y$ and $y < m \div 3$ is the quotient when m is divided by 3. So, that many times p is added, before we terminate recursion by satisfying the end condition $Q(m, n) = 0$, if $m < n$. Hence the result.
18. Since the access is sequential, greater the distance, greater will be the access time. Since all the files are referenced with equal frequency, overall access time can be reduced by arranging them as in option (a).

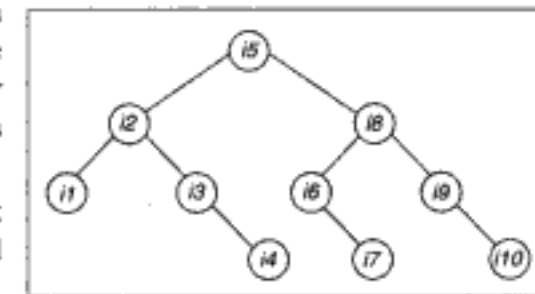

Fig. 9.12

111. Consider the following two functions.

$$f(n) = n^3, \text{ if } 0 \leq n < 10,000$$

$$n^2, \text{ otherwise}$$

$$g(n) = n, \text{ if } 0 \leq n < 100$$

$$n^2 + 5n, \text{ otherwise}$$

Which of the following is/are true?

- (a) $f(n)$ is $O(n^3)$ (b) $g(n)$ is $O(n^3)$
 (c) $O(f(n))$ is same as $O(g(n))$ (d) $g(n)$ is $O(n^2)$
- *112. A 3-ary tree is a tree in which every internal node has exactly 3 children. The number of leaf nodes in such a tree with 6 internal nodes will be
 (a) 10 (b) 23 (c) 17 (d) 13
113. The concatenation of two lists is to be performed in $O(1)$ time. Which of the following implementations of a list could be used?
 (a) Singly linked list (b) Doubly linked list
 (c) Circular doubly linked list (d) Array implementation of list
114. The correct matching for the following pairs is
 (A) All pairs shortest path (1) Greedy
 (B) Quick sort (2) Depth-first search
 (C) Minimum weight spanning tree (3) Dynamic programming
 (D) Connected Components (4) Divide and conquer
 (a) A-2, B-4, C-1, D-3 (b) A-3, B-4, C-1, D-2
 (c) A-3, B-4, C-2, D-1 (d) A-4, B-1, C-2, D-3
115. Which of the following is essential for converting an infix expression to the postfix form efficiently?
 (a) An operator stack (b) An operand stack
 (c) An operator stack and an operand stack (d) A parse tree
- *116. A binary search tree contains the values -1, 2, 3, 4, 5, 6, 7, and 8. The tree is traversed in preorder and the values are printed out. Which of the following sequences is a valid output?
 (a) 5 3 1 2 4 7 8 6 (b) 5 3 1 2 6 4 9 7
 (c) 5 3 2 4 1 6 7 8 (d) 5 3 1 2 4 7 6 8
117. Let $T(n)$ be the function defined by

$$T(1) = 1, \text{ if } n = 1$$

$$= 2T(\lfloor n/2 \rfloor) + \sqrt{n}, \text{ for } n \geq 2$$
 Which of the following statements is true?
 (a) $T(n) = O(\sqrt{n})$ (b) $T(n) = O(n)$
 (c) $T(n) = O(\log n)$ (d) None of the above
118. Which of the following need not be a binary tree?
 (a) Search tree (b) Heap (c) AVL-Tree (d) B-Tree
- *119. Assume 5 buffer pages are available to sort a file of 105 pages. The cost of sorting using m-way merge sort is
 (a) 206 (b) 618 (c) 840 (d) 926

- *13. The principle that a function can always be replaced by its value (irrespective of the context) without changing the meaning is called
 (a) referential transparency (b) orthogonality
 (c) context-free (d) unbinding
14. Programming languages offer features to write functions to
 (a) facilitate the implementation of top-down logic
 (b) enhance logical clarity
 (c) avoid programming across programs
 (d) none of the above
15. The following pseudo-Pascal procedure

```

procedure palin;
var c : char;
begin
    read(c);
    if NOT eoln then palin;
    write(c);
end
  
```

 can be used to
 (a) check if a given string is palindrome or not
 (b) explain the concept of recursion
 (c) reverse a given string
 (d) delete a given line of text
- *16. In a certain language, the expression $5-3+2 \times 4+1$, evaluates to 0. Which of the following conclusions about the precedence and associativity of the operators +, -, * are correct?
 (a) + has precedence over - and - has precedence over *
 (b) All these have equal precedence and associate to the right
 (c) All these have equal precedence and associate to the left
 (d) + and - have equal precedence, which is over * and all associate to the left
17. The output of the following pseudo-Pascal program is

```

var a : integer;
procedure p;
begin
    a := 2; write(a)
end
begin
    a := 1; p; write(a)
end
  
```

 (a) 2, 1 (b) 1, 2 (c) 2, 2 (d) 1, 1

18. Which of the following comparisons between static and dynamic type checking is incorrect?

- (a) Dynamic type checking slows down execution.
- (b) Dynamic type checking offers more flexibility to the programmers.
- (c) Dynamic type checking is more reliable.
- (d) Unlike static type checking, dynamic type checking is done during compilation.

19. The period of time between an allocation and its subsequent disposal is called

- (a) scope
- (b) (dynamic) binding
- (c) lifetime
- (d) longevity

20. Consider the following pseudo-Pascal program.

```

procedure A;
  x,y : integer;
  procedure B;
    x,z : real;
    statement 1
  end B;
  procedure C;
    i : integer;
    statement 2
  end C;
end A;

```

The variables accessible in statement 1 and statement 2 are

- (a) x of A; x, y of B; z in statement 1 and x of B; y, i in statement 2
- (b) x of B; y, z in statement 1 and x of B; i, z in statement 2
- (c) x of B; z, y in statement 1 and x of A; i and y in statement 2
- (d) none of the above

21. Consider the following sequence of statements

```

Statement 1: A := B+C
Statement 2: D := A+C
Statement 3: E := A+B
Statement 4: G := D-E
Statement 5: H := E+A
Statement 6: I := H+G

```

Which of the statements can be executed in parallel?

- (a) 2 and 4
- (b) 4 and 5
- (c) 5 and 6
- (d) 4, 5 and 6

22. If instructions are executed in parallel, whenever the required operands are available, then the execution time of the previous problem is logically same as that of sequentially executing

- (a) 3 statements
- (b) 2 statements
- (c) 4 statements
- (d) 5 statements

23. Aliasing is a situation where

- (a) two commands with different names share the same code

102. If the hashing function is the remainder on division, then clustering is more likely to occur if the storage space is divided into 40 sectors rather than 41. This conclusion is

- (a) more likely to be false
- (b) more likely to be true
- (c) is always false
- (d) none of the above

103. Unrestricted use of `goto` is harmful, because it

- (a) makes debugging difficult
- (b) increases the running time of programs
- (c) increases memory requirement of programs
- (d) results in the compiler generating longer machine code

104. The maximum degree of any vertex in a simple graph with n vertices is

- (a) n
- (b) $n-1$
- (c) $n+1$
- (d) $2n-1$

105. The recurrence relation that arises in relation with the complexity of binary search is

- (a) $T(n) = T(n/2) + k$, where k is a constant
- (b) $T(n) = 2T(n/2) + k$, where k is a constant
- (c) $T(n) = T(n/2) + \log(n)$
- (d) $T(n) = T(n/2) + n$

106. An item that is read as input can be either pushed to a stack and later popped and printed, or printed directly. Which of the following will be the output if the input is the sequence of items - 1, 2, 3, 4, 5?

- (a) 3, 4, 5, 1, 2
- (b) 3, 4, 5, 2, 1
- (c) 1, 5, 2, 3, 4
- (d) 5, 4, 3, 1, 2

107. Which of the following algorithm design technique is used in the quick sort algorithm?

- (a) Dynamic programming
- (b) Backtracking
- (c) Divide and conquer
- (d) Greedy method

108. Linked lists are not suitable for implementing

- (a) insertion sort
- (b) binary search
- (c) radix sort
- (d) polynomial manipulation

109. Which one of the following statements is false?

- (a) Optimal binary search tree construction can be performed efficiently using dynamic programming.
- (b) Breadth-first search cannot be used to find connected components of a graph.
- (c) Given the prefix and postfix walks of a binary tree, the binary tree cannot be uniquely reconstructed.
- (d) Depth-first search can be used to find the connected components of a graph.

*110. The number of edges in a regular graph of degree d and n vertices is

- (a) maximum of n, d
- (b) $n+d$
- (c) nd
- (d) $nd/2$

91. Stack is useful for implementing
 (a) radix sort (b) breadth first search
 (c) recursion (d) depth first search
- *92. To store details of an employee, a storage space of 100 characters is needed. A magnetic tape with a density of 1000 characters per inch and an inter-record gap of 1 inch is used to store information about all employees in the company. What should be the blocking factor so that the wastage does not exceed one-third of the tape?
 (a) 0.05 (b) 20 (c) 10 (d) 0.1
- *93. A machine needs a minimum of 100 sec to sort 1000 names by quick sort. The minimum time needed to sort 100 names will be approximately
 (a) 50.2 sec (b) 6.7 sec (c) 72.7 sec (d) 11.2 sec
- *94. A machine took 200 sec to sort 200 names, using bubble sort. In 800 sec, it can approximately sort
 (a) 400 names (b) 800 names (c) 750 names (d) 800 names
- *95. The correct order of arrangement of the names Bradman, Lamb, May, Boon, Border, Underwood and Boycott, so that the quicksort algorithm makes the least number of comparisons is
 (a) Bradman, Border, Boon, Boycott, May, Lamb, Underwood
 (b) Bradman, Border, Boycott, Boon, May, Underwood, Lamb
 (c) Underwood, Border, Boon, Boycott, May, Lamb, Bradman
 (d) Bradman, May, Lamb, Border, Boon, Boycott, Underwood
- *96. Which of the following is useful in traversing a given graph by breadth first search?
 (a) Stack (b) Set (c) List (d) Queue
97. Which of the following is useful in implementing quick sort?
 (a) Stack (b) Set (c) List (d) Queue
98. Queue can be used to implement
 (a) radix sort (b) quick sort (c) recursion (d) depth first search
- *99. The expression tree given in Fig. 9.10 evaluates to 1, if
 (a) $a = -b$ and $e = 0$ (b) $a = -b$ and $e = 1$
 (c) $a = b$ and $e = 0$ (d) $a = b$ and $e = 1$
- *100. A hash function randomly distributes records one by one in a space that can hold x number of records. The probability that the m^{th} record is the first record to result in collision is
 (a) $(x-1)(x-2)\dots(x-(m-2))(m-1) / x^{m-1}$
 (b) $(x-1)(x-2)\dots(x-(m-1))(m-1) / x^{m-1}$
 (c) $(x-1)(x-2)\dots(x-(m-2))(m-1) / x^m$
 (d) $(x-1)(x-2)\dots(x-(m-1))(m-1) / x^m$

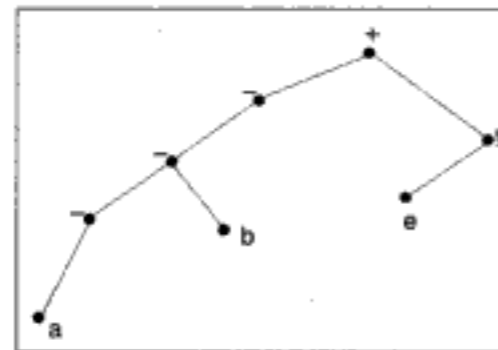

Fig. 9.10

101. The process of accessing data stored in a tape is similar to manipulating data on a
 (a) stack (b) queue (c) list (d) heap

- (b) a particular location is associated with more than one name
 (c) different functions have the same name but require parameters of different types
 (d) none of the above
24. Consider the following variant record declaration in pseudo-Pascal.

```

type abc = record
  x : integer;
  case y : integer of
    1 : (m : integer, n : real);
    2 : (e, f : integer);
  end

```

 Suppose a program uses an array of 'P' such records. Integer needs 2 bytes of storage and real r bytes. If the array occupies 480 bytes, the value of P will be
 (a) 80 (b) 50 (c) 25 (d) 60
- *25. A recursive function $f(x)$, is defined as follows:

```

if(x>100)
  return (x-10)
else return(f(f(x+11)))

```

 For which of the following values of x , $f(x) = 91$?
 (a) 100 (b) 91 (c) 1 (d) 101
- *26. English language uses full stop as a sentence
 (a) separator (b) terminator
 (c) separator and terminator (d) none of the above
- *27. In a hypothetical language, all operators have equal precedence and associate to the left. In this language, the expression $5 \times 3 - 2 - 1 \times 2$ evaluates to
 (a) 15 (b) 11 (c) 8 (d) 20
- *28. Overloading is
 (a) functions having the same name but with different types of parameters
 (b) a function used very frequently in a program
 (c) an operator whose meaning is determined by the operand type
 (d) all of the above
29. You are asked to use a computer to solve a problem given to you. How fast the computer solves your problem, depends on the
 (a) algorithm used (b) language used for implementation
 (c) programmer (d) computer
30. Which of the following is a dangling reference?
 (a) Accessing a storage that is already disposed at the request of the user
 (b) Accessing a storage that is already disposed at the request of the processor
 (c) Accessing a variable that is declared but not initialized
 (d) None of the above

31. Heap allocation is required for languages that
- support recursion
 - support dynamic data structures
 - use dynamic scope rules
 - none of the above
32. Jensen's device makes explicit use of the property of
- value parameters
 - reference parameters
 - name parameters
 - value-result parameters
33. For which of the following applications will you prefer a co-routine to a subroutine?
- Simulation of multi-processing
 - Complex searching process
 - Handling inter-leaved lists
 - None of the above
34. Binding (of an identifier to a value) can occur while
- writing a program
 - compiling a program
 - invoking a sub-program
 - executing a program
- *35. COMMON feature of FORTRAN is not found in most of the languages that followed it because
- it is difficult to implement
 - memory is not of primary concern now-a-days
 - virtual memory concept obviates it
 - of its potential side-effects
- *36. Consider the following program fragment.
- ```

procedure exchange(A: integer, B: integer)
 temp : integer;
begin
 temp := A; A := B; B := temp
end;
begin
 M := 2; X[M] := 4;
 exchange(M, X[M]); write(M, x[2]);
end

```
- If the parameters are passed by value, the output will be
- unpredictable
  - 2, 4
  - 4, 2
  - 2, 2
- \*37. 4, 2 will be the output of the previous question if the parameters are passed by
- reference
  - name
  - value
  - none of the above
- \*38. If the parameters are passed by name, the output will be
- 2, 2
  - 4, 4
  - 2, 4
  - 4, 2

81. The postfix expression for the infix expression  $A + B * (C + D) / F + D * E$  is:
- $AB + CD + *F / D + E*$
  - $ABCD + *F / + DE* +$
  - $A*B + CD / F*DE ++$
  - $A + *BCD / F*DE ++$
- \*82. Which of the following statements is true?
- As the number of entries in the hash table increases, the number of collisions increases.
  - Recursive programs are efficient.
  - The worst time complexity of quick sort is  $O(n^2)$ .
  - Binary search implemented using a linked list is efficient.
- I and II
  - II and III
  - I and IV
  - I and III
- \*83. The number of binary trees with 3 nodes which when traversed in post-order gives the sequence A, B, C is
- 3
  - 9
  - 7
  - 5
84. The minimum number of colors needed to color a graph having  $n (>3)$  vertices and 2 edges is
- 4
  - 3
  - 2
  - 1
85. Which of the following file organizations is preferred for secondary key processing?
- Indexed sequential file organization
  - Two-way linked list
  - Inverted file organization
  - Sequential file organization
86. Mr. Fool designed a crazy language called STUPID that included the following features.
- + has precedence over /
  - / has precedence over - (binary)
  - (binary) has precedence over \*
  - \* and ^ (exponentiation) have the same precedence.
  - + and \* associate from right to left.
- The rest of the mentioned operators associate from left to right. Choose the correct stack priorities Mr. Fool should assign to +, \*, ^, / respectively, for correctly converting an arithmetic expression in infix form to the equivalent postfix form.
- 5, 1, 2, 4
  - 5, 5, 2, 4
  - 1, 1, 2, 4
  - 5, 4, 3, 1
87. The infix priorities of +, \*, ^, / could be
- 5, 1, 2, 7
  - 7, 5, 2, 1
  - 1, 2, 5, 7
  - 5, 2, 2, 4
88. Mr. Fool's STUPID language will evaluate the expression  $2 * 2 ^ 3 * 4$  to
- 256
  - 64
  - $4^{12}$
  - $4^{81}$
89. The expression  $1 * 2 ^ 3 * 4 ^ 5 * 6$  will be evaluated to
- $32^{30}$
  - $162^{30}$
  - 49152
  - 173458
90. In a circularly linked list organization, insertion of a record involves the modification of
- no pointer
  - 1 pointer
  - 2 pointers
  - 3 pointers

45. Which of the following sorting algorithm has the worst time complexity of  $n \log(n)$ ?  
 (a) Heap sort (b) Quick sort (c) Insertion sort (d) Selection sort
46. Which of the following sorting methods sorts a given set of items that is already in sorted order or in reverse sorted order with equal speed?  
 (a) Heap sort (b) Quick sort (c) Insertion sort (d) Selection sort
- \*47. Which of the following algorithms solves the all-pair shortest path problem?  
 (a) Dijkstra's algorithm (b) Floyd's algorithm  
 (c) Prim's algorithm (d) Warshall's algorithm
- \*48. Consider the graph in Fig. 9.4.  
 The third row in the transitive closure of the above graph is  
 (a) 1,1,1 (b) 1,1,0  
 (c) 1,0,0 (d) 0,1,1
- \*49. The eccentricity of node labeled 5 in the graph in Fig. 9.5 is  
 (a) 6 (b) 7  
 (c) 8 (d) 5
- \*50. The center of the graph in Qn. 49 is the node labeled  
 (a) 1 (b) 2  
 (c) 3 (d) 4
51. Stack A has the entries  $a, b, c$  (with  $a$  on top). Stack B is empty. An entry popped out of stack A can be printed immediately or pushed to stack B. An entry popped out of stack B can only be printed. In this arrangement, which of the following permutations of  $a, b, c$  is not possible?  
 (a)  $b a c$  (b)  $b c a$   
 (c)  $c a b$  (d)  $a b c$
- \*52. In the previous problem, if the stack A has 4 entries, then the number of possible permutations will be  
 (a) 24 (b) 12 (c) 21 (d) 14
53. The information about an array that is used in a program will be stored in  
 (a) symbol table (b) activation record (c) system table (d) dope vector
54. Which of the following expressions accesses the  $(i,j)^{\text{th}}$  entry of a  $(m \times n)$  matrix stored in column major form?  
 (a)  $n \times (i-1) + j$  (b)  $m \times (j-1) + i$   
 (c)  $m \times (n-j) + j$  (d)  $n \times (m-i) + j$
55. Sparse matrices have  
 (a) many zero entries (b) many non-zero entries  
 (c) higher dimension (d) none of the above

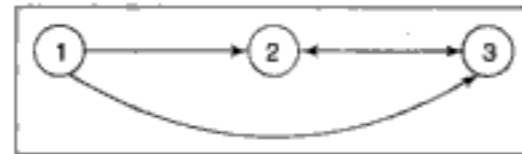

Fig. 9.4

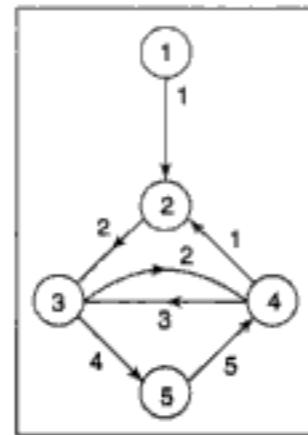

Fig. 9.5

- \*39. Choose the correct remarks that are based on the following pseudo-Pascal function.
- ```
function doit(x, y : integer) : integer;
begin
  if(x = 0) then doit := y
  else if (y = 0) then doit := x
  else doit := doit(x-1, y-1)
end
```
- (a) It loops infinitely for some x, y .
 (b) It doesn't work if x and y are both 0.
 (c) Finds the greater of the two given non-negative integers.
 (d) Finds the positive difference of two given non-negative integers.
- *40. Which of the following can be correctly identified to be Pascal tokens without look-ahead scanning?
 (a) $:$ (b) $:=$ (c) end (d) $<$
- *41. Consider the following pseudo-Pascal program (assume $(*$ starts a comment and $*)$ ends a comment)
- ```
procedure doit(A, B, C) : integer;
begin
 B := B-2; C := A+C(*; write(C) *)
end;
var A, B : integer;
begin
 A := 10; B := 20; doit(A, A, A); write(A)
end
```
- If this program prints 16, then  $A, B, C$  should have been declared as  
 (a) all variable parameters (b) only  $A$  and  $B$  are variable parameters  
 (c) only  $A$  and  $C$  are variable parameters (d) only  $B$  and  $C$  are variable parameters
- \*42. If the comment is removed in the previous problem, it will print 18, 8, if the parameter declaration is  
 (a) only  $A$  and  $B$  are variable parameters (b) only  $B$  and  $C$  are variable parameters  
 (c) only  $A$  and  $C$  are variable parameters (d) all variable parameters
- \*43. The vernacular language English can't be used as a Computer Programming language because  
 (a) it includes symbols that are not present in the keyboard  
 (b) it doesn't have a well-defined syntax  
 (c) it is ambiguous  
 (d) computers do not understand English
44. Choose the correct statements.  
 (a) In general, there is always an iterative equivalent of a recursive definition.  
 (b) Recursion and iteration are equally powerful.

- (c) In iteration(unlike recursion), the body is carried out to completion each time, before the condition for termination is tested.  
 (d) Recursion is more powerful than iteration.
45. Binding cannot be done  
 (a) when separately compiled modules are being linked together  
 (b) during loading  
 (c) while writing a program  
 (d) none of the above
46. The target of an assignment statement should be  
 (a) l-value (b) either l-value or r-value  
 (c) r-value (d) none of the above
47. Which of the following problems are iterative, rather than recursive in nature?  
 (a) Simplex method for solving a linear programming problem.  
 (b) Newton-Raphson method for finding the roots of an equation.  
 (c) 8-Queen's problem.  
 (d) Depth first traversal of a given tree.
48. BNF is a meta-language for  
 (a) specifying the syntax of a language  
 (b) specifying a context free grammar  
 (c) describing how a program works  
 (d) shell programming
49. The basic difference between a procedural language and an applicative language is that the  
 (a) latter executes by evaluating expressions predominantly  
 (b) latter uses parameters, rather than assignment statements to communicate values  
 (c) former executes by evaluating expressions predominantly  
 (d) former uses parameters, rather than assignment statements to communicate values
50. The output of the following Pascal program is
- ```

program x;
var char, real : integer;
false : boolean;
begin
  char := 1; real := char; false := (char = real);
  if(false = true) then writeln('Don't Worry')
  else writeln('Be Happy')
end
  
```
- (a) a compilation error message (b) Don't Worry
 (c) a run time error message (d) Be Happy

- *33. What should be the relation between $T(1)$, $T(2)$ and $T(3)$, so that Qn. 32, gives an algorithm whose order is constant?
 (a) $T(1) = T(2) = T(3)$ (b) $T(1) + T(3) = 2T(2)$
 (c) $T(1) - T(3) = T(2)$ (d) $T(1) + T(2) = T(3)$
34. The Ackermann's function
 (a) has quadratic time complexity (b) has exponential time complexity
 (c) can't be solved iteratively (d) has logarithmic time complexity
- *35. The order of an algorithm that finds whether a given Boolean function of 'n' variables, produces a 1 is
 (a) constant (b) linear (c) logarithmic (d) exponential
- *36. In evaluating the arithmetic expression $2 * 3 - (4 + 5)$, using stacks to evaluate its equivalent post-fix form, which of the following stack configuration is not possible?
- (a)

4
6

 (b)

5
4
6

 (c)

9
6

 (d)

9
3
2
37. The way a card game player arranges his cards as he picks them up one by one, is an example of
 (a) bubble sort (b) selection sort (c) insertion sort (d) merge sort
38. You want to check whether a given set of items is sorted. Which of the following sorting methods will be the most efficient if it is already in sorted order?
 (a) Bubble sort (b) Selection sort (c) Insertion sort (d) Merge sort
- *39. The average number of comparisons performed by the merge sort algorithm, in merging two sorted lists of length 2 is
 (a) $8/3$ (b) $8/5$ (c) $11/7$ (d) $11/6$
40. Which of the following sorting methods will be the best if number of swappings done, is the only measure of efficiency?
 (a) Bubble sort (b) Selection sort (c) Insertion sort (d) Quick sort
41. You are asked to sort 15 randomly generated numbers. You should prefer
 (a) bubble sort (b) quick sort (c) merge sort (d) heap sort
42. As part of the maintenance work, you are entrusted with the work of rearranging the library books in a shelf in proper order, at the end of each day. The ideal choice will be
 (a) bubble sort (b) insertion sort (c) selection sort (d) heap sort
- *43. The maximum number of comparisons needed to sort 7 items using radix sort is (assume each item is a 4 digit decimal number)
 (a) 280 (b) 40 (c) 47 (d) 38
44. Which of the following algorithms exhibits the unnatural behavior that, minimum number of comparisons are needed if the list to be sorted is in the reverse order and maximum number of comparisons are needed if they are already in sorted order?
 (a) Heap sort (b) Radix sort
 (c) Binary insertion sort (d) There can't be any such sorting method

- *22. The running time $T(n)$, where 'n' is the input size of a recursive algorithm is given as follows.

$$T(n) = c + T(n - 1), \text{ if } n > 1 \\ d, \text{ if } n \leq 1$$

The order of this algorithm is

- (a) n^2 (b) n (c) n^3 (d) n^n
23. There are 4 different algorithms A1, A2, A3, A4 to solve a given problem with the order $\log(n)$, $\log(\log(n))$, $n\log(n)$, $n/\log(n)$ respectively. Which is the best algorithm?
- (a) A1 (b) A2 (c) A4 (d) A3
- *24. The number of possible binary trees with 3 nodes is
- (a) 12 (b) 13 (c) 5 (d) 15
- *25. The number of possible binary trees with 4 nodes is
- (a) 12 (b) 13 (c) 14 (d) 15
26. The time complexity of an algorithm $T(n)$, where n is the input size is given by
- $$T(n) = T(n - 1) + 1/n, \text{ if } n > 1 \\ 1, \text{ otherwise}$$
- The order of this algorithm is
- (a) $\log n$ (b) n (c) n^2 (d) n^n
27. Sorting is useful for
- (a) report generation (b) minimizing the storage needed
(c) making searching easier and efficient (d) responding to queries easily
28. Choose the correct statements.
- (a) Internal sorting is used if the number of items to be sorted is very large.
(b) External sorting is used if the number of items to be sorted is very large.
(c) External sorting needs auxiliary storage.
(d) Internal sorting needs auxiliary storage.
29. A sorting technique that guarantees, that records with the same primary key occurs in the same order in the sorted list as in the original unsorted list is said to be
- (a) stable (b) consistent (c) external (d) linear
- *30. A text is made up of the characters a, b, c, d, e each occurring with the probability .12, .4, .15, .08 and .25 respectively. The optimal coding technique will have the average length of
- (a) 2.15 (b) 3.01 (c) 2.3 (d) 1.78
31. In the previous question, which of the following characters will have codes of length 3?
- (a) Only c (b) Only b (c) b and c (d) Only d
- *32. The running time of an algorithm is given by
- $$T(n) = T(n - 1) + T(n - 2) - T(n - 3), \text{ if } n > 3 \\ n, \text{ otherwise.}$$
- The order of this algorithm is
- (a) n (b) $\log n$ (c) n^n (d) n^2

Mr. Genius developed a language called Great, with the following instructions.

```
clr x - sets x to 0
inc x - increments x by 1
dec x - decrements x by 1
inv x - if x is non-zero, x will be set to 0.
        if x is zero, x will be set to 1.
```

The only control feature available is:

```
while x not 0
do
  statement list
end
```

The following 7 questions are based on this new language. Assume variables take the value 0 or any positive integer.

51. This language is as powerful as
- (a) COBOL (b) LISP (c) C (d) C++
- *52. One of the four instructions is not needed. That is
- (a) clr x (b) inc x (c) dec x (d) inv x
53. The program
- ```
clr C; clr B;
while (A not 0)
do
 inc C; dec A;
end;
while(C not 0)
do
 inc A; inc B; dec C;
end
```
- (a) transfers the contents of A to B (b) copies the contents of A to B  
(c) copies the contents of A to B and C (d) transfers the contents of A to C
54. The program
- ```
clr C;
while A not 0
do
  clr x;
  while (B not 0)
  do
    inc C; inc x; inc B;
  end;
  while (x not 0)
  do
    inc B; dec x;
  end;
  dec A;
end
```
- (a) computes $A+B$ (b) computes $A-B$ (c) computes $A \times B$ (d) computes $A \times A$

55. If we add one more instruction `cpy x, y` - which copies the contents of `x` to `y`, then the following program,

```

clr C; cpy A, x;
while(x not 0)
do
  cpy x, y;
  while(y not 0)
  do
    inc C; dec y;
  end;
  dec x;
end

```

- (a) finds $1+2+3+\dots+A$ (b) computes $A+A$
 (c) computes $A*A$ (d) computes $A+x$

56. The following program

```

cpy A, x; clr C;
while(x not 0)
do
  inv C; dec x;
end

```

- (a) assigns 0 to C
 (b) assigns 1 to C
 (c) assigns 0 to C, if A is even, else assigns 1 to C
 (d) assigns 0 to C, if A is odd, else assigns 1 to C

57. The following program

```

cpy A, x;
while(x not 0)
do
  inv M; clr x;
end;
cpy A, x; inv x;
while(x not 0)
do
  inc M; clr x;
end

```

- (a) computes $M+x$
 (b) does not change the value of M
 (c) does the same thing as - if A not 0 then inv M else inc M
 (d) does the same thing as - if A not 0 then inc M else inv M

- *13. The average successful search time taken by binary search on a sorted array of 10 items is
 (a) 2.6 (b) 2.7 (c) 2.8 (d) 2.9

- *14. A hash function f defined as $f(\text{key}) = \text{key} \bmod 7$, with linear probing, is used to insert the keys 37, 38, 72, 48, 98, 11, 56, into a table indexed from 0 to 6. What will be the location of key 11?

- (a) 3 (b) 4 (c) 5 (d) 6

- *15. The average successful search time for sequential search on 'n' items is

- (a) $n/2$ (b) $(n-1)/2$ (c) $(n+1)/2$ (d) $\log(n) + 1$

16. The running time of an algorithm $T(n)$, where 'n' is the input size is given by

$$T(n) = 8T(n/2) + qn, \text{ if } n > 1$$

$$p, \text{ if } n = 1$$

where p, q are constants. The order of this algorithm is

- (a) n^2 (b) n^n (c) n^3 (d) n

- *17. Let m, n be positive integers. Define $Q(m,n)$ as

$$Q(m, n) = 0, \text{ if } m < n$$

$$Q(m - n, n) + p, \text{ if } m \geq n$$

Then $Q(m, 3)$ is (a div b, gives the quotient when a is divided by b)

- (a) a constant (b) $p \times (m \bmod 3)$ (c) $p \times (m \text{ div } 3)$ (d) $3 \times p$

- *18. Six files F_1, F_2, F_3, F_4, F_5 and F_6 have 100, 200, 50, 80, 120, 150 number of records respectively. In what order should they be stored so as to optimize access time? Assume each file is accessed with the same frequency.

- (a) $F_3, F_4, F_1, F_5, F_6, F_2$

- (b) $F_2, F_6, F_5, F_1, F_4, F_3$

- (c) $F_1, F_2, F_3, F_4, F_5, F_6$

- (d) Ordering is immaterial as all files are accessed with the same frequency.

- *19. In Qn. 18, the average access time will be

- (a) 268 units (b) 256 units (c) 293 units (d) 210 units

- *20. An algorithm is made up of 2 modules M_1 and M_2 . If order of M_1 is $f(n)$ and M_2 is $g(n)$ then the order of the algorithm is

- (a) $\max(f(n), g(n))$ (b) $\min(f(n), g(n))$

- (c) $f(n) + g(n)$ (d) $f(n) \times g(n)$

21. The concept of order (Big O) is important because

- (a) it can be used to decide the best algorithm that solves a given problem

- (b) it determines the maximum size of a problem that can be solved in a given system, in a given amount of time

- (c) it is the lower bound of the growth rate of the algorithm

- (d) none of the above

- If this tree is used for sorting, then a new number 8 should be placed as the
- (a) left child of the node labeled 30 (b) right child of the node labeled 5
(c) right child of the node labeled 30 (d) left child of the node labeled 10
3. The initial configuration of a queue is a, b, c, d , (' a ' is in the front end). To get the configuration d, c, b, a , one needs a minimum of
- (a) 2 deletions and 3 additions (b) 3 deletions and 2 additions
(c) 3 deletions and 3 additions (d) 3 deletions and 4 additions
- *4. The number of possible ordered trees with 3 nodes A, B, C is
- (a) 16 (b) 12 (c) 6 (d) 10
5. The number of swappings needed to sort the numbers 8, 22, 7, 9, 31, 19, 5, 13 in ascending order, using bubble sort is
- (a) 11 (b) 12 (c) 13 (d) 14
- *6. Given two sorted list of size ' m ' and ' n ' respectively. The number of comparisons needed in the worst case by the merge sort algorithm will be
- (a) $m \times n$ (b) maximum of m, n
(c) minimum of m, n (d) $m + n - 1$
7. If the sequence of operations - push(1), push(2), pop, push(1), push(2), pop, pop, pop, push(2), pop, are performed on a stack, the sequence of popped out values are
- (a) 2, 2, 1, 1, 2 (b) 2, 2, 1, 2, 2
(c) 2, 1, 2, 2, 1 (d) 2, 1, 2, 2, 2
- *8. A hash table with 10 buckets with one slot per bucket is depicted in Fig. 9.3. The symbols, S1 to S7 are initially entered using a hashing function with linear probing. The maximum number of comparisons needed in searching an item that is not present is
- (a) 4 (b) 5 (c) 6 (d) 3
- *9. A binary tree in which every non-leaf node has non-empty left and right subtrees is called a strictly binary tree. Such a tree with 10 leaves
- (a) cannot have more than 19 nodes (b) has exactly 19 nodes
(c) has exactly 17 nodes (d) cannot have more than 17 nodes
- *10. The depth of a complete binary tree with ' n ' nodes is (\log is to the base two)
- (a) $\log(n+1) - 1$ (b) $\log(n)$
(c) $\log(n-1) + 1$ (d) $\log(n) + 1$
11. Preorder is same as
- (a) depth-first order (b) breadth-first order
(c) topological order (d) linear order
- *12. Which of the following traversal techniques lists the nodes of a binary search tree in ascending order?
- (a) Post-order (b) In-order (c) Pre-order (d) None of the above

0	S7
1	S1
2	
3	S4
4	S2
5	
6	S5
7	
8	S6
9	S3

Fig. 9.3

58. In which of the following cases, is it possible to obtain different results for call-by-reference and call-by-name parameter passing?
- (a) Passing an expression as a parameter (b) Passing an array as a parameter
(c) Passing a pointer as a parameter (d) Passing an array element as a parameter

The next two questions are based on the following program segment in pseudo-Pascal.

```

var x, y : integer;
procedure A(var z : integer);
var x : integer;
begin
  x := 1; B; z := x;
end;
procedure B;
begin
  x := x-1;
end;
begin
  x := 5; A(y); write(y);
end

```

59. If the language uses static scope rules, the output will be
- (a) 0 (b) 3 (c) 4 (d) 5
60. If the language uses dynamic scope rules, the output will be
- (a) 0 (b) 3 (c) 4 (d) 5
61. What will the following function compute?
- ```

function what(x, n : integer) : integer;
var
 value : integer;
begin
 value := 1;
 if(n > 0) then
 begin
 if(n mod 2 = 1) then
 value := value*x;
 value := value*what(x*x, n div 2);
 end;
 what := value;
end;

```
- (a)  $x+n$  (b)  $x*n$  (c)  $x*x$  (d)  $x^n$

62. An array  $A$  consists of  $n$  integers in locations  $A[0], A[1], \dots, A[n-1]$ . It is required to shift the elements of the array cyclically to the left by  $k$  places, where  $1 \leq k \leq n - 1$ . An incomplete algorithm for doing this in linear time, without using another array is given below. Complete the algorithm by filling in the blanks. Assume all variables are suitably declared.

```

min := n; i := 0;
while (_____) do
begin
temp := A[i]; j := i;
while (_____) do
begin
A[j] := _____; j := (j+k) mod n;
if(j < min) then
min := j;
end;
A[(n+i-k) mod n] := _____;
i := _____;
end;

```

- (a)  $i > \text{min}; j := (n+i) \bmod n; A[j+k]; \text{temp}; i+1;$   
 (b)  $i < \text{min}; j := (n+i) \bmod n; A[j+k]; \text{temp}; i+1;$   
 (c)  $i > \text{min}; j := (n+i+k) \bmod n; A[j+k]; \text{temp}; i+1;$   
 (d)  $i < \text{min}; j := (n+i-k) \bmod n; a[(j+k) \bmod n]; \text{temp}; i+1;$

The next two questions are based on the following program.

```

program main;
var r: integer;
procedure two;
begin write(r) end;
procedure one;
var r: integer;
begin r := 5; two; end;
begin
r := 2; two; one; two;
end

```

63. If static scoping is used by all variables, the output will be  
 (a) 222 (b) 255 (c) 252 (d) 555
64. If dynamic scoping is used by all the variables, the output will be  
 (a) 222 (b) 255 (c) 252 (d) 555

# Chapter 9

## Data Structures

- \*1. Consider the following tree

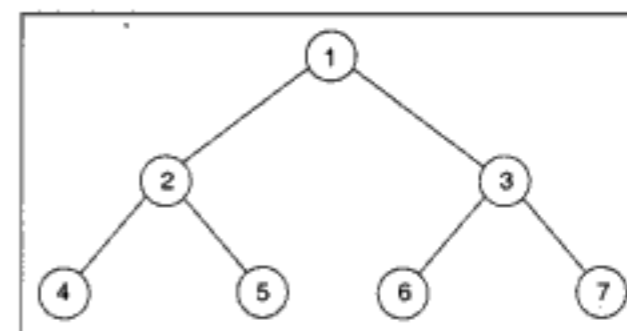

Fig. 9.1

If the post order traversal gives  $a b - c d * +$  then the label of the nodes 1, 2, 3, ... will be

- (a) +, -, \*, a, b, c, d (b) a, -, b, +, c, \*, d  
 (c) a, b, c, d, -, \*, + (d) -, a, b, +, \*, c, d
- \*2. Consider the following tree.

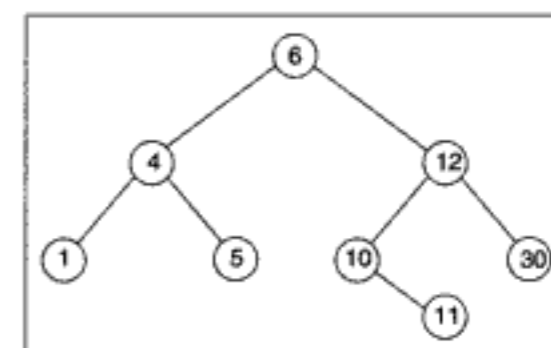

Fig. 9.2



Taking  $a=b=c=-1$  and  $d = -5/2$ ,  $ax+by+cz < d$  becomes  $-x-y-z < 5/2$ .

This is true if  $x=y=z=1$ . For all other Boolean combinations of  $x, y, z$ , this is false. Hence the correct option is (b).

105. Another name for Gray code is unit-distance code.

108. Option (b) is  $(A+B)(A+C) = AA + AC + BA + BC$   
 $= A + AC + BA + BC$   
 $= A(1 + C + B) + BC$   
 $= A + BC$

110. P is the carry and Q is the sum. Check it yourself.

122. Shift and add are the primitive operations.

123. For example consider 10101011. Number of 1's in even places is 1. Number of 1's in odd places is 4. The difference  $4 - 1$ , is divisible by 3. So, the binary number 10101011 (i.e. decimal 171) is divisible by 3, which is true.

125. There can't be any such number. Because, if such a number say  $x$ , exists then  $x+x' = 2^d - 1$ , i.e.,  $x+x = 15$ , (since  $x' = x$ ), which is not true for any integer  $x$ .

126. 64 K is  $2^{16}$  bytes. i.e.  $16^4$  bytes i.e., 10000 bytes in hex code.  
 So last accessible address is  $10000-1 = FFFF$ .

128. The largest ' $n$ ' bit binary number is  $2^n - 1$ . If its equivalent decimal number has ' $d$ ' digits then it has to be less than  $10^d$ . So,  $2^n - 1 < 10^d$ , i.e.  $2^n < 10^d$  (approximately), so  $d > n \log_{10} 2$ .

129. Addition will be performed first.  $a + b$  will evaluate to ' $b$ ' as the significant digits of ' $a$ ' will be lost when it is converted to exponent 11. So,  $a + b - b$  is  $b - b$ , which is 0.

131. If it is to be divisible by 4, then both the two least significant bits has to be 0. So, only option (b) is divisible by 4.

149. Frequency = 3 MHz. So, time per T-state =  $1/3 \text{ MHz} = 3.33 \times 10^{-7}$  sec. Number of T-states = 13.

Total time =  $13 \times 3.33 \times 10^{-7} = 4333 \text{ ns}$ .

208. If one CPU completes its operation before the other, the result will be its original value. If one CPU has already fetched the value of  $x$ , and is in the process of updating it and at this point of time the other CPU fetches the value of  $x$  (which will be same as the value fetched by the first CPU), the first CPU after manipulating it will store back the result in  $x$ . After this the second CPU will store its manipulated value, over-writing what is stored by the first CPU. So, the final value may be its original value +1 if the first CPU decremented  $x$ , its original value - 1, otherwise.

228. Even with a single processor, parallelism can be achieved by overlapping instruction fetch, decode, address calculation, operand fetch and execution of different instructions simultaneously.

231.  $m*a = (a*b)*a = (a'+b)*a = (a'+b)'*a = ab'+a = a(b'+1) = a$

65. Consider the recursive function

```
function fib(n : integer) : integer;
begin
 if(n = 0) or (n = 1) then fib := 1
 else fib := fib(n-1)+fib(n-2)
end;
```

The function is run on a computer with a stack of size 64 bytes. If only the return address and parameter are passed to the stack and they need two bytes each, estimate the maximum value of  $n$  for which the stack does not overflow.

(a) 4 (b) 6 (c) 10 (d) 9

66. FORTRAN does not permit recursion because

- (a) it uses static allocation for storing variables
- (b) it uses dynamic allocation for storing variables
- (c) stacks are not available in all machines
- (d) it is not possible to implement recursion on all machines

67. A data driven machine is one that executes an instruction if the needed data is available. The physical ordering of the code listing does not dictate the course of execution. Consider the following pseudo-code.

- (A) Multiply E by 0.5 to get F
- (B) Add A and B to get E
- (C) Add B with 0.5 to get D
- (D) Add E and F to get G
- (E) Add A with 10.5 to get C

Assume A, B, C are already assigned values and the desired output is G.

Which of the following sequence of execution is valid?

- (a) B, C, E, A, D
- (b) C, B, E, A, D
- (c) A, B, C, D, E
- (d) E, D, C, B, A

\*68. In the previous question, in how many different ways can the 5 instructions be sequenced?

- (a) 10 (b) 8 (c) 6 (d) 12

\*69. In a demand-driven machine, an instruction is not executed until its output is needed. For the previous question, in what order will the instructions be sequenced?

- (a) D, B, A, C, E
- (b) A, B, C, D, E
- (c) E, D, C, B, A
- (d) None of the above

70. Choose the correct statements.

- (a) Step-wise refinement uses top-down methodology
- (b) Step-wise refinement uses bottom-up methodology
- (c) Use of library routines facilitate bottom-up methodology
- (d) None of the above

71. The following is an incomplete pseudo-Pascal function to convert a given decimal integer (in the range -8 to 7) into a binary integer in 2's complement form. Determine the expressions that complete the program.



```

function TWOCOMP(N : integer) : integer;
var
 REM, EXPO, BINARY : integer;
begin
 if (n ≥ - 8) and (N ≤ 7) then
 begin
 if N < 0 then
 N := ...;
 BINARY := 0; EXPO := 1;
 while N <> 0 do
 begin
 REM := N mod 2;
 BINARY := BINARY + ... * EXPO;
 EXPO := EXPO*10;
 N := ...;
 end;
 TWOCOMP := BINARY
 end
 end;
end;

```

- (a)  $N+1$ ; REM;  $N \text{ div } 2$                       (b)  $N+16$ ; REM;  $N \text{ div } 2$   
 (c)  $N+1$ ; REM;  $N \text{ mod } 2$                       (d)  $N+16$ ; REM;  $N \text{ mod } 2$

2. In the following pseudo-Pascal program segment, the value  $x$ , after the execution of the program is

```

X := -10;
y := 20;
if X>Y
then
 if X<0
 then X := abs(X)
 else X := 2*x;

```

- (a) 20                      (b) 30                      (c) -10                      (d) -20

3. Consider the following macro definition.

```

macro Add x, y
 Load y
 Mul x
 Store y
end macro

```

$x$  and  $y$  are

- (a) variables              (b) identifiers              (c) actual parameters              (d) formal parameters

43.

| DE | ABC |     |     |     |     |     |     |     |
|----|-----|-----|-----|-----|-----|-----|-----|-----|
|    | 000 | 001 | 011 | 010 | 110 | 111 | 101 | 100 |
| 00 |     |     |     |     |     |     |     |     |
| 01 |     |     | 1   | 1   | 1   | X   |     |     |
| 11 |     |     | 1   | 1   | X   | 1   |     |     |
| 10 | 1   | 1   |     |     |     |     | X   | 1   |

Fig. 8.11

The terms  $A'BE$  corresponds to  $A' = 0$ ;  $B = 1$ ;  $E = 1$ ;  $C = 0$  or  $1$ ;  $D = 0$  or  $1$ . Similarly mark all 1's and get the Karnaugh map as above. The 1's can be covered in the optimal way, if the slots marked X are set to 1's. So the three X's in the positions  $ABCD'E$ ,  $ABC'DE$ ,  $AB'CDE'$  are the don't care conditions to be set to 1 and used. Hence the answer is (c).

50. The circuit is  $(A'B')' = A + B$ . Hence the answer.  
 51. To convert to base 8, we group in 3's, because  $2^3 = 8$ .  
 To convert to base 16, we group in 4's, because  $2^4 = 16$ .  
 To convert to base 32, we group in 5's because  $2^5 = 32$ .  
 Grouping in 5's, from the right, we can get the answer.  
 52. It is commutative because  $A \oplus B = B \oplus A$   
 It is associative because  $(A \oplus B) \oplus C = A \oplus (B \oplus C)$   
 It is not distributive over AND because  
 $A \oplus (B \text{ AND } C) = (A \oplus B) \text{ AND } (A \oplus C)$   
 is not true. For e.g.,  $1 \oplus (0 \text{ AND } 1) = 1$   
 But  $(1 \oplus 0) \text{ AND } (1 \oplus 1) = 1 \text{ AND } 0 = 0$   
 57.  $X + Y = 0$  (Construct the truth table and verify)  
 So,  $A \oplus B = C \Rightarrow A \oplus (A + B) = A \oplus C$   
 $\Rightarrow (A \oplus A) \oplus B = A \oplus C$   
 $0 \oplus B = A \oplus C$   
 $B = A \oplus C$

Similarly, (b) and (c) can be proved.

59. Converting to base 2, the equation reads  
 $001\ 001\ A\ 001\ B = 0001\ 0010\ 1100\ 1001$   
 Here A, B stand for a group of binary digits. So, grouping the right hand side in 3's, from the right and matching corresponding groups in both the sides, we get  $B = 001$  and  $A = 011$ .  
 So,  $A=3$  and  $B=1$ .  
 60. A single Boolean variable can take the values either 0 or 1, i.e., 2 possible ways. So, 'n' Boolean variables can take  $2 \times 2 \times 2 \dots$  (n times) values, i.e.,  $2^n$  times. So, the truth table will have  $2^n$  rows. Each row can be assigned one of the 2 values 0 or 1. So, totally  $2^{2^n}$  functions are possible. So, none of the given choices is true.

So, it suffices to prove NAND is a universal gate.

If that is true, it should simulate any Boolean operator. Since the basic operations are OR, AND, and complementation, it is enough to prove NAND can simulate these.

Refer Qn. 25 to see how OR can be simulated.

It is simple to simulate complementation.

$$\text{NAND}(A, A) = A'$$

AND can be simulated as follows.

$$\text{NAND}(A, B) = (AB)'$$

$$\text{NAND}((AB)', (AB)') = AB$$

Hence the correct answers are (a) and (b).

32. Don't care conditions need or need not be present. If present, they need or need not be used. If they aid in the simplification process, we use them to our advantage. Otherwise they are literally don't care.

33.  $AB + AB' + A'C + AC = A(B + B') + (A' + A)C$   
 $= A(1) + (1)C = A + C$ , which is independent of B.

34. The given expression is  $AB + AB' + A'C = A(B + B') + A'C = A(1) + A'C$   
 $= A + A'C = A + C$  (Refer Qn. 16)

So, one needs just a single OR gate to implement the given Boolean expression.

38.  $(A + C)(AB' + AC) = AAB' + AAC + ACB' + CAC$   
 $= AB' + AC + CAB' + AC$  (Since  $X.X = X$ )  
 $= AB' + CAB' + AC$  (Since  $X + X = X$ )

So the given Boolean expression is

$$(AB' + CAB' + AC)(A'C' + B') = AB'A'C' + AB'B' + CAB'A'C' + CAB'B'$$

$$+ ACA'C' + ACB'$$

$$= 0 + AB' + 0 + CAB' + 0 + ACB'$$

$$= AB' + CAB' = AB'(1 + C) = AB'$$

39. To specify a particular operation, out of the  $2^n$  possible operations, one needs  $n$  bits. As the machine is byte addressable, to specify a particular byte we need  $(m + 10)$  bits (since  $2^{(m+10)}$  bytes are there). So 3 addresses and 1 operation needs  $3(m + 10) + n = 3m + n + 30$  bits.

40. Refer Qn. 39.

If it is word addressable, then the number of words is  $2^{(m+10)}$  divided by  $2^3$ , i.e.,  $2^{m+7}$  words. So, one needs  $3(m + 7) + n = 3m + n + 21$  bits.

41. It is  $2m + n$ . ' $n$ ' columns for the ' $n$ ' inputs;  $2m$  columns for storing the ' $m$ ' present states and ' $m$ ' next states.

\*74. Which of the following strings can definitely be said to be tokens without looking at the next input character while compiling a Pascal program.

- I. begin                      II. program                      III. <>  
 (a) I only                      (b) II only                      (c) III only                      (d) All of the above

75. Assume X and Y are non-zero positive integers. The following pseudo-Pascal program

```
while X <> Y do
 if X > Y then X := X-Y
 else Y := Y-X;
write(X);
```

- (a) computes the LCM of two numbers  
 (b) divides the larger number by the smaller number  
 (c) computes the GCD of two numbers  
 (d) finds the smaller of two numbers

76. The value of X printed by the following pseudo-Pascal program is

```
program COMPUTE(input, output);
var
 X : integer;
procedure FIND(X : real);
begin
 X := sqrt(X);
end;
begin
 X := 2; FIND(X); writeln(X)
end.
```

- (a) 2                      (b)  $\sqrt{2}$                       (c) Run-time error                      (d) none of the above

\*77. A language with string manipulation facilities uses the following operations.

- head(s) - returns the first character of string s.  
 tail(s) - returns all but the first character of string s.  
 concat(s1, s2) concatenates strings s1 and s2  
 The output of concat(head(s), head(tail(tail(s)))) , where s is acbc, is  
 (a) ab                      (b) ba                      (c) ac                      (d) aa

\*78. Which of the following statements are true?

- I. As the number of entries in the hash table increases, the number of collisions increases.  
 II. Recursive programs are efficient.  
 III. The worst case complexity of Quick sort is  $O(n^2)$ .  
 IV. Binary search using a linear linked list is efficient.  
 (a) I and II                      (b) II and III                      (c) I and IV                      (d) I and III

\*79. Consider the following high level program segment.

```
var
 A, B, W, X, Y : unsigned byte;
 Z: unsigned integer;
begin
 X := A+B;
 Y := abs(A-B);
 W := A-B;
 Z := A*B;
end
```

Assuming integer occupies 2 bytes and the initial values of A and B are 5CH and 92H respectively, the final values of W, X, Y and Z will be

- (a) CAH, EEH, 36H, 3478H      (b) AH, EEH, 36H, 3478H  
 (c) AH, EBH, 36H, 3478H      (d) CAH, EBH, 36H, 3478H

\*80. Consider the following pseudo-Pascal function, where A and B are non-zero positive integers. What is the value of GET(3,2)?

```
function GET(A, B : integer) : integer;
begin
 if B = 0
 then
 GET := 1
 else if A < B
 then
 GET := 0
 else
 GET := GET(A-1,B) + GET(A-1,B-1)
end;
```

- (a) 1      (b) 2      (c) 3      (d) 7

\*81. A variant record in Pascal is defined as

```
type varirec = record
 number: integer;
 case (var1, var2) of
 var1 : (x, y : integer);
 var2 : (P, q : real)
 end
end
```

Suppose an array of 100 such records was declared on a machine, which uses 4 bytes for an integer and 8 bytes for a real. How much space would the compiler have to reserve for the array?

- (a) 2800      (b) 2400      (c) 2000      (d) 1200

17. Obviously it shows it is associative. It implies (by the law of duality), the associativity of AND also. Complementing both sides,

$$(X + (Y + Z))' = ((X + Y) + Z)'$$

$$X'(Y'Z') = (X'Y')Z'$$

(By De Morgan's law)

22. Karnaugh map is just pictorial representation of a truth table. By covering the 1's, we get the sum of product form. By covering the 0's and then complementing, we get the product of sum form.

23. Consider the decimal digit 5. Its BCD representation is 0101. If complemented, we get 1010, i.e., 15 - 5. In general, complementing  $x$  gives  $15 - x$ . But correct complemented value should be  $9 - x$ . The difference of 6 can be nullified by going for excess-3 code. (3 because using it twice, i.e., during the conversion and reconversion process one can account for the excess 6.) If a number system uses 20 as the radix, each digit needs 5 bits in the equivalent BCD form. So, complement of  $x$ , gives  $31 - x$ . But the correct value is  $19 - x$ . To account for the excess  $31 - 19$ , i.e., 12, we have to use excess-6 code. e.g., take 11. Its complement should be  $19 - 11 = 8$ . In excess-6 code, we add 6 to 11, to get 17. Complementing, we get  $31 - 17 = 14$ . If we subtract the excess 6, we get  $14 - 6 = 8$ , which is the required answer.

25. By NAND gate as follows.

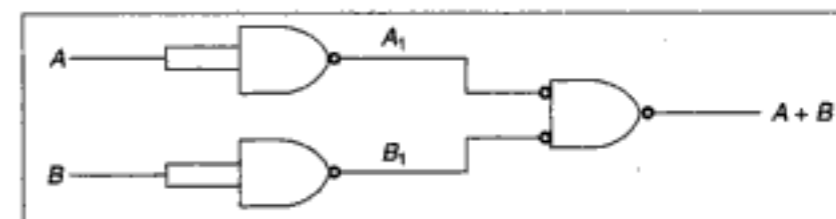

Fig. 8.10(a)

By NOR gate as follows.



Fig. 8.10(b)

28. 90 - 10 is a heuristic rule that says 90% of the execution time is spent on 10% of the code.

29. Consider the decimal digit 5. Its BCD form is 0101. Complementing, we get 1010, which is decimal 10. To make 1010 correspond to decimal 4 (which is the correct complement of 5), we can assign the weights 2-4-2-1. This way 1010, will be decimal 4.

31. NOR and NAND are universal gates.

NAND can be simulated by NOR as follows.

$$\text{NAND}(A, B) = A' + B'$$

$$\text{NOR}(A, A) = A'$$

$$\text{NOR}(B, B) = B'$$

$$\text{NOR}(A', B') = (A' + B')' = AB$$

$$\text{NOR}(AB, AB) = (AB)' = A' + B' = \text{NAND}(A, B)$$

- |        |        |           |           |           |
|--------|--------|-----------|-----------|-----------|
| 181. b | 182. a | 183. c    | 184. a    | 185. b    |
| 186. c | 187. c | 188. b    | 189. b    | 190. d    |
| 191. c | 192. c | 193. b    | 194. b    | 195. b    |
| 196. b | 197. d | 198. b, c | 199. a    | 200. a    |
| 201. b | 202. c | 203. a    | 204. d    | 205. c    |
| 206. a | 207. c | 208. d    | 209. d    | 210. d    |
| 211. a | 212. c | 213. c    | 214. b    | 215. b    |
| 216. a | 217. d | 218. b    | 219. d    | 220. b    |
| 221. b | 222. d | 223. b    | 224. d    | 225. b, c |
| 226. c | 227. a | 228. d    | 229. b, c | 230. a    |
| 231. b | 232. b | 233. b    | 234. c    |           |

### Explanations

- Exclusive OR takes the value 0 if there are even number of 1's.
- X can take the value of either 1 or 0. Substitute and verify the identities.
- Form truth table and check the correctness of the options (c) and (d).
- Substitute and verify each of the possibilities.
- During execution of the current instruction the content is incremented so that it points to the next instruction.
- Converting to decimal form, the given equation is  
 $3 + (2 \times 5) + (1 \times 5 \times 5) = 3 + A \times B$  i.e.,  $38 = A \times B + 3$ . So,  $A \times B = 35$ . Possible values for A, B are 1, 35; 5, 7; 7, 5; 35, 1.  
 7, 5 and 35, are infeasible, as permissible digits for a number in base 'r' are 0, 1, 2, ... (r-1). Hence 1 and 5 are the possible values of A.
- Refer Qn. 10. Converting to decimal form,  $A + 2 \times 3 + 1 \times 3 \times 3 = 3 + 2 \times A + 1 \times A \times A$ . Solving for A, we get  $A = -4$  or 3. Both are infeasible.
- The contents of a word may represent an instruction or data. Just by looking at the contents, it is not possible to attach any meaning to it. A word pointed to by the program counter, is an instruction. Otherwise it need not be. Also, the word data has context sensitive meaning. One can write a program in Pascal that needs radius as the input data. The program, as a whole, is input data for the compiler during the compilation process.
- $X + X'Y = X.1 + X'Y = X(1 + Y) + X'Y = X.1 + XY + X'Y$   
 $= X + (X + X')Y = X + 1.Y = X + Y$   
 If that sounds quite unnatural, here is another way. Let  $K = X + X'Y$  (we have to find K)  
 Complementing both sides  $K' = (X + X'Y)' = X' . (X + Y')$   
 $= X'X + X'Y' = 1 + X'Y'$   
 $= X'Y'$   
 Again complementing both sides  $K = (X'Y')' = X+Y$   
 Hence the answer is (a).

Let the symbol D stand for a variable that is defined or refined. Let the symbol K stand for a variable that is killed. Let the symbol U stand for a variable that is used. The next four questions are based on the above notations.

- Consider the assignment statement  
 $var1 = var1 + var2;$   
 The sequence of notations that correctly reflects the usage of the variable var1 is  
 (a) KD (b) D (c) UD (d) UKD
- Which of the following sequences (for a particular variable) is harmless but suspicious?  
 (a) DU (b) KD (c) UU (d) DD
- Which of the following sequences (for a particular variable) are probably bugs?  
 (a) KK (b) UK (c) KU (d) DK
- In addition to the above notations, let us use the notation -X, where X is one of D, K or U, to mean that nothing of interest (concerning the variable under consideration) happened to the variable. Which of the following situations are probably anomalous?  
 (a) -U (b) -D (c) -K (d) None of the above
- Vernacular languages (like English) and programming languages have a lot of similarities. In a broad sense, the nouns and verbs are comparable to  
 (a) operators and identifiers respectively (b) operands and identifiers respectively  
 (c) operands and operators respectively (d) operators and functions respectively
- Consider the following C program.  

```
#include "stdio.h"
main()
{
 enum boolean {true, false};
 enum boolean a, b, c;
 a = b = true;
 c = (a==b);
 if (c == a)
 printf("TRUE");
 else
 printf("FALSE");
}
```

The output of the above program will be

- (a) TRUE (b) FALSE (c) computer dependent (d) unpredictable

### Answers

- |             |       |       |             |          |
|-------------|-------|-------|-------------|----------|
| 1. b        | 2. d  | 3. a  | 4. a, d     | 5. d     |
| 6. d        | 7. c  | 8. d  | 9. c        | 10. a    |
| 11. b, c, d | 12. d | 13. a | 14. a, b, c | 15. b, c |



- |                |          |             |                |                |
|----------------|----------|-------------|----------------|----------------|
| 16. a, d       | 17. c    | 18. a, b    | 19. c          | 20. c          |
| 21. a, b       | 22. c    | 23. a, b    | 24. d          | 25. a, b, c, d |
| 26. b          | 27. a    | 28. a, c    | 29. a, b, c, d | 30. a, b, c    |
| 31. b          | 32. c    | 33. a, b, c | 34. a, b, c, d | 35. b, c, d    |
| 36. b          | 37. a    | 38. b       | 39. a, d       | 40. b          |
| 41. a          | 42. a    | 43. c       | 44. a, b, c    | 45. d          |
| 46. a          | 47. a, b | 48. a, b    | 49. a, b       | 50. b          |
| 51. a, b, c, d | 52. a    | 53. b       | 54. c          | 55. a          |
| 56. c          | 57. c    | 58. a       | 59. c          | 60. a          |
| 61. d          | 62. d    | 63. a       | 64. a          | 65. b          |
| 66. a          | 67. a, b | 68. d       | 69. d          | 70. a, c       |
| 71. b          | 72. c    | 73. d       | 74. c          | 75. c          |
| 76. a          | 77. a    | 78. d       | 79. a          | 80. c          |
| 81. c          | 82. d    | 83. d       | 84. a, c, d    | 85. a, c       |
| 86. c          | 87. b    |             |                |                |

### Explanations

3. Had the statement been `DO5I = 1.10`, `DO` would not have been a keyword, but a prefix of the token `DO5I`. So, the compiler has to scan till `,` to make sure `DO` is used as a keyword.
5. There is no relationship between code size and execution time. For example, use of recursion, generally results in compact code, but execution time will be more.
7. As an implication of this, `int if;` is an illegal C declaration, but `int IF;` is legal.
8. Data-flow languages, uses the availability of information rather than the logical or physical ordering of instructions in a program to decide whether an instruction is to be executed. So, the tenth instruction may get executed before the sixth if the information needed for the execution of the tenth instruction is available before the information needed for the sixth is available. This way, data-flow languages exploit the inherent parallelism in a particular program.
10. APL also evaluates an arithmetic expression, the same way as a calculator.
13. Orthogonality is the principle that each component of a language should be independent of the other components. Context-free in a broad sense means replacement of one pattern by another, irrespective of the context.
16. In option (a), the expression is equivalent to  $(5 - (3 + 2) \times (4 + 1))$ , which evaluates to 0.  
In option (b), it is  $((((5 - 3) + 2) \times 4) + 1)$ , which yields 17.  
In option (c), it is  $(5 - (3 + (2 \times (4 + 1))))$ , which evaluates to 8.  
In option (d), it is  $((5 - (3 + 2)) \times (4 + 1))$ , which evaluates to 0.

### Answers

- |              |                |                |                |                |
|--------------|----------------|----------------|----------------|----------------|
| 1. c         | 2. b, c, d     | 3. a, c        | 4. c, d        | 5. a           |
| 6. a, c      | 7. b           | 8. b, c        | 9. a, c        | 10. d          |
| 11. a, b     | 12. d          | 13. b, c, d    | 14. c          | 15. a, b, c    |
| 16. a        | 17. b, c       | 18. a, b, c    | 19. a, c, d    | 20. c          |
| 21. b, d     | 22. a, b, c    | 23. c          | 24. a, b, c, d | 25. a, b       |
| 26. b, c     | 27. c          | 28. a, b, c, d | 29. c          | 30. a          |
| 31. a, b     | 32. c          | 33. b          | 34. d          | 35. a, b, c    |
| 36. a, b, d  | 37. a          | 38. a          | 39. d          | 40. d          |
| 41. c        | 42. d          | 43. c          | 44. b          | 45. b          |
| 46. b        | 47. b          | 48. d          | 49. a          | 50. a          |
| 51. a        | 52. a, b       | 53. c, d       | 54. d          | 55. c          |
| 56. b, d     | 57. a, b, c    | 58. a, b, c, d | 59. d          | 60. d          |
| 61. c        | 62. a          | 63. a          | 64. a          | 65. d          |
| 66. c        | 67. a          | 68. c          | 69. c          | 70. d          |
| 71. c        | 72. b          | 73. b          | 74. d          | 75. c, d       |
| 76. b        | 77. c          | 78. a          | 79. d          | 80. b          |
| 81. d        | 82. a, b, c, d | 83. c          | 84. c          | 85. a, b, c, d |
| 86. a        | 87. b, c       | 88. a, b       | 89. d          | 90. b          |
| 91. b, c     | 92. b          | 93. b, d       | 94. c          | 95. c          |
| 96. d        | 97. d          | 98. b          | 99. b          | 100. b         |
| 101. c       | 102. a         | 103. b         | 104. b         | 105. c         |
| 106. c       | 107. b         | 108. b         | 109. b         | 110. a         |
| 111. d       | 112. a         | 113. c         | 114. c         | 115. d         |
| 116. b       | 117. a         | 118. c         | 119. b         | 120. b         |
| 121. c       | 122. c         | 123. d         | 124. c         | 125. c         |
| 126. d       | 127. a         | 128. d         | 129. c         | 130. d         |
| 131. a, c, d | 132. b         | 133. a, c      | 134. d         | 135. c         |
| 136. b       | 137. b         | 138. a         | 139. d         | 140. c         |
| 141. b       | 142. a, b      | 143. c         | 144. b, d      | 145. a         |
| 146. c       | 147. b         | 148. a         | 149. a         | 150. d         |
| 151. a       | 152. b         | 153. a         | 154. c         | 155. c         |
| 156. b       | 157. c         | 158. d         | 159. c         | 160. c         |
| 161. b       | 162. d         | 163. b         | 164. b         | 165. d         |
| 166. d       | 167. b         | 168. c         | 169. b, c      | 170. b         |
| 171. b       | 172. d         | 173. c         | 174. a         | 175. d         |
| 176. a       | 177. b         | 178. b         | 179. a         | 180. b, c      |

225. If a particular idea can be implemented in hardware or software, the factor(s) that favour hardware implementation is/are  
 (a) cost-effectiveness (b) speed of operation  
 (c) reliability (d) frequent changes expected
226. Tera is 2 to the power of  
 (a) 32 (b) 30 (c) 40 (d) 25
227. Von Neumann architecture is  
 (a) SISD (b) SIMD (c) MIMD (d) MISD
- \*228. To achieve parallelism, one needs a minimum of  
 (a) 2 processors (b) 3 processors  
 (c) 4 processors (d) none of the above
229. SIMD can be used for  
 (a) railway reservation (b) weather forecasting  
 (c) matrix multiplication (d) all of the above
230. A typical application of MIMD is  
 (a) railway reservation (b) weather forecasting  
 (c) matrix multiplication (d) all of the above
- \*231. Let \* be a defined as  $a*b = a' + b$ . Let  $m = a*b$ . The value of  $m*a$  is  
 (a)  $a' + b$  (b)  $a$  (c) 0 (d) 1
232. The correct matching for the following pairs is  
 (A) DMA I/O (1) High speed RAM  
 (B) Cache (2) Disk  
 (C) Interrupt I/O (3) Printer  
 (D) Condition Code Register (4) ALU  
 (a) A-4, B-3, C-1, D-2 (b) A-2, B-1, C-3, D-4  
 (c) A-4, B-3, C-2, D-1 (d) A-2, B-3, C-4; D-1
233. Contents of A register after the execution of the following 8085 microprocessor program is  
 MVI A, 55h  
 MVI C, 25h  
 ADD C  
 DAA  
 (a) 7Ah (b) 80h (c) 50h (d) 22h
234. RST 7.5 interrupt in 8085 microprocessor executes service routine from interrupt vector location  
 (a) 0000h (b) 0075h (c) 003Ch (d) 0034h

25. In fact  $f(x)$  will be 91 for any  $x$  less than 101. Let us use the short form  $f^3(x)$ , to denote  $f(f(f(x)))$ . What will be the value of  $f^n(91)$ ?  
 $f^n(91) = f^{n+1}(102) = f^n(92) = f^{n+1}(103)$  etc.,  
 At some stage, it will be  $f^n(100) = f^{n+1}(111) = f^n(101) = f^{n-1}(91)$ . We started with  $f^n(91)$  and reduced it to  $f^{n-1}(91)$ . This  $n-1$  can be reduced  $n-2$ , etc.,. Ultimately one gets  $f^1(91)$ , which can be proved to be 91, using the same logic.  
 What is left to be proved is, if you start with any number less than 101, you should be getting  $f^n(91)$ , for some  $n$ . This is obvious because we keep on adding 11, till the argument falls in the range 101 to 111. Afterwards, a 111 becomes 91 in two steps - 101 becomes 91 in one step. For any other number in this range, we subtract 10 and in the next step, add 11. The net effect is adding 1 to the number. Progressing this way, one gets 111, which will be reduced to 91 in two steps.
26. There are two views regarding the use of semi-colon in the programming languages. Some languages (like PL/I) use it as a terminator while some languages (like Pascal) use it as a separator. In English it is used as a terminator, for the simple reason—if it is a separator, the last sentence should not end with a full stop.
27. In this language, the given expression is equivalent to  $(5 \times (3 - (2 - (1 \times 2))))$ , which evaluates to 15.
28. + is an operator that can act on operands of different types. The actual addition process depends on the type. So, + is said to be overloaded. Similarly, a function like write can take arguments of different types. So, it is also overloaded.
35. FORTRAN was developed at a time when large memories were expensive. So, to make optimal use of available memory, the idea of many variables sharing the same space was supported, in spite of the inherent dangers. This is the reason why FORTRAN doesn't support the space consuming recursion technique.
36. If the parameters are passed by value, the function will be manipulating a local copy of the argument value. Any change will be local to the function and hence will not be reflected in the calling environment.
37. In call by reference, the address of the actual arguments will be passed to the function. Any change done inside the function will be reflected outside the function also.
38. In this case, the following statements will be executed by the function.  $temp := M$ ;  $M := X[M]$ ;  $X[M] := temp$ ; So, what is evaluated is  $temp := 2$ ;  $M := X[2]$ ;  $X[M] := temp$ ; i.e., M will be assigned 4, after which  $X[M]$ , i.e.,  $X[4]$  will be assigned 2.  $X[2]$  remains unaltered. So, 4, 4 will be printed.
39. If  $x$  and  $y$  are negative integers, this loops infinitely resulting in abnormal termination because of stack overflow. If 0, 0 is the input 0 will be returned.
40. end may be prefix of an identifier.  
 <, if followed by =, can't be treated as a single entity.  
 :, if followed by =, can't be treated as a single entity.
41. If A, B, C are all declared to be variable parameters, the call `doit(A, A, A)` executes the statements -  $A := A - 2$ ;  $A := A + A$ ; i.e., it evaluates  $A := 10 - 2$ ;  $A := 8 + 8$ ; Because of the variable parameter declaration, these changes will be global. Hence 16 will be printed.

42. Refer Qn. 41. If A and B are declared as variable parameters, what is evaluated is  $A:=10-2$ ;  $A:=8+10$ ; This 18 will have no impact outside as it is assigned to C, a local variable. So, it prints 18 and 8.
43. A word may have more than one meaning. We use our common sense to decide in what sense it is used in the current context which a computer can't.
50. In Pascal, pre-defined meaning of the standard identifiers can be changed by the user. Here the standard identifiers `false`, `char`, `real` are used as user-defined variables.
52. `clr x` can be simulated as :
- ```
while x not 0
do
    dec x
end.
Another way is :
inc x
inv x
```
58. Instructions B, C, and E can be executed in any order. Instruction A can be executed after executing instruction B. So, 12 possible ways.
59. Instruction C and instruction E will never get executed as their output is not needed.
72. Since the condition $X > Y$ fails, execution takes the `else` route, which does nothing. So the value of X will remain unchanged.
74. `beginabc` is a single token representing an identifier. Just after scanning the symbols `b`, `e`, `g`, `i`, `n`, — it should not be incorrectly grouped as the keyword `begin`. For similar reasons, program cannot be grouped as a keyword, without scanning the delimiter. But, `<>` can be grouped as a Boolean operator, does not matter what symbol is following the `>`.
77. `tail(s)` returns `cbc`. `tail(tail(s))` returns `bc`. So the given operation reduces to `concat(head(acbc), head(bc))`, which is `concat(a,b)` — which is the string `ab`.
78. Recursive program takes more time than its equivalent non-recursive version and so is not efficient. This is because of the function call overhead.
- In binary search since every time, the current list is probed at the middle, random access is preferred. Since linked list does not support random access, binary search implemented this way is inefficient.
79. The values of the variables W, X, Y and Z after the execution of the program will be `CAH`, `EEH`, `36H`, and `3478H`.
80. $GET(3,2) = GET(2,2) + GET(2,1)$
 $= GET(1,2) + GET(1,1) + GET(1,1) + GET(1,0)$
 $= 0 + GET(1,1) + GET(1,1) + 1$
 $= 2 \times (GET(0,1) + GET(0,0)) + 1$
 $= 2 + 1 = 3.$
81. number field is compulsory. This needs 4 bytes. `var1` needs $4 + 4 = 8$ bytes of memory. `var2` needs $8 + 8 = 16$ bytes of memory. So the compiler will allocate $\max(8, 16) = 16$ bytes. So, totally $4 + 16 = 20$ bytes. To store 100 such records, one needs 2000 bytes of memory.

- (c) is useful when small programs are to be run
 (d) all of the above

215. The output of the multiplexer circuit in Fig. 8.9 can be represented by
 (a) $AB + BC' + C'A + BC$
 (b) $A + B + C$
 (c) $A + B$
 (d) $A'B'C + A'BC' + ABC$

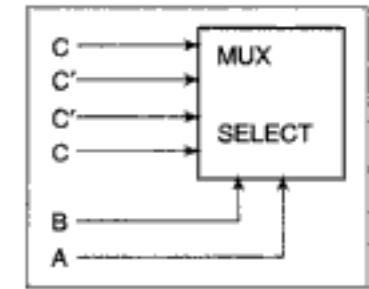

Fig. 8.9

216. In a 11 bit computer instruction format, the size of address field is 4 bits. The computer uses expanding OP code technique and has 5 two-address instructions and 32 one-address instructions. The number of zero address instructions it can support is
 (a) 256 (b) 2048 (c) 16 (d) 272
217. `PCHL` is an instruction in 8085 which transfers the contents of the register pair HL to PC. This is not a commonly used instruction as it changes the flow of control in a rather unstructured fashion. This instruction cannot be used in implementing.
 (a) `if... then ... else` construct
 (b) `while ... do` construct
 (c) `case ... structure`
 (d) `call ... statement`
218. To change an upper case character to a lower case character in ASCII, the correct mask and operation should be
 (a) `0100000` and NOR (b) `0100000` and OR
 (c) `0100000` and NAND (d) `1011111` and AND
219. The number of flip-flops needed to construct a binary modulo N counter is
 (a) N (b) 2^N (c) N^2 (d) $\log_2 N$
220. Multiplexing of data/address lines in an 8085 microprocessor reduces the instruction execution time. This statement is
 (a) true (b) false
 (c) most likely to be true (d) none of the above
221. Which of the following is unipolar, difficult to fabricate, has very high speed and offers good resistance to radiation?
 (a) ECL (b) GaAs (c) TTL (d) CMOS
222. What is $A*A$, if * is a Boolean operation defined by $A*B = AB + A'B'$?
 (a) A (b) B (c) 0 (d) 1
223. If $C = A*B$, then $C*A$ is
 (a) A (b) B (c) 0 (d) 1
224. The Boolean variables A, B and C, that solve the Boolean equations $AB + A'C = 1$ and $AC + B = 0$ simultaneously is
 (a) 1, 0, 0 (b) 0, 1, 1 (c) 1, 0, 1 (d) 0, 0, 1

```
XYZ:   PCHL
       HLT
```

Pick out the correct statement from the following:

- (a) the program will branch to 0000H after JM XYZ
- (b) the program will branch to 0008H after JM XYZ
- (c) the program will halt the processor
- (d) the program will be repeated infinitely

198. Assume that the 8255 gets selected whenever A15-A11 are high during I/O read or write cycles. The A2 and A1 are connected to A1 and A0 of 8255 chip. Then, the address for port C of 8255 is

- (a) 03h
- (b) FEh
- (c) FFh
- (d) FF03h

199. Assume that a slow memory device is interfaced with an 8085 microprocessor and an 1-wait state generating circuit is connected to READY input. Then, the execution time needed for the following program would be,

```
LDA TEMP
ADD B
LHLD TEMP
```

- (a) 43 T-states
- (b) 30 T-states
- (c) 40 T-states
- (d) 33 T-states

200. Which of the following instructions may be used to save the accumulator value onto the stack?

- (a) PUSH PSW
- (b) PUSH A
- (c) PUSH SP
- (d) POP PSW

201. A single instruction to clear the lower four bits of the accumulator in 8085 assembly language is

- (a) XRI 0FH
- (b) ANI 0FH
- (c) XRI 0FH
- (d) ANI 0FH

202. Which of the following statements is true?

- (a) ROM is a read/write memory.
- (b) PC points to the last instruction that was executed.
- (c) Stack works on the principle of LIFO.
- (d) All instructions affect the flag.

203. In a vectored interrupt the

- (a) branch address is assigned to a fixed location in memory.
- (b) interrupting source supplies the branch information to the processor through an interrupt vector
- (c) branch address is obtained from a register in the processor
- (d) none of the above

204. A sequence of two instructions that multiplies the contents of the DE register pair by 2 and stores the result in the HL register pair (in 8085 assembly language) is

- (a) XCHG and DAD B
- (b) XTHL and DAD H
- (c) PCHL and DAD D
- (d) XCHG and DAD H

Chapter 4

Mathematical Foundations of Computer Science

- *1. A class of 30 students occupy a classroom containing 5 rows of seats, with 8 seats in each row. If the students seat themselves at random, the probability that the sixth seat in the fifth row will be empty is
 - (a) 1/5
 - (b) 1/3
 - (c) 1/4
 - (d) 2/5
- *2. The probability that a number selected at random between 100 and 999 (both inclusive) will not contain the digit 7 is
 - (a) 16/25
 - (b) $(9/10)^3$
 - (c) 27/75
 - (d) 18/25
- *3. 0.152525252... is same as
 - (a) 52/99
 - (b) 151/990
 - (c) 51/99
 - (d) none of the above
- *4. A class is composed of 2 brothers and 6 other boys. In how many ways can all the boys be seated at a round table so that the two brothers are not seated together?
 - (a) 3600
 - (b) 3000
 - (c) 2600
 - (d) 2050
- *5. The n^{th} order difference of a polynomial of degree n is
 - (a) zero
 - (b) one
 - (c) some constant
 - (d) undefined
- *6. Each coefficient in the equation $ax^2 + bx + c = 0$ is determined by throwing an ordinary die. The probability that the equation will have real roots is
 - (a) 57/216
 - (b) 27/216
 - (c) 53/216
 - (d) 43/216
- *7. The sum of all numbers greater than 10,000 formed by using the digits 0, 2, 4, 6, 8, no digit being repeated in any number, is
 - (a) 5199960
 - (b) 2742790
 - (c) 2449002
 - (d) 8411420

- *8. For a game in which 2 partners oppose 2 other partners, six men are available. If every possible pair must play against every other pair, the number of games to be played is
 (a) 36 (b) 45 (c) 42 (d) 90
- *9. Let the elements g, h belong to a group G . If $O(h)$ is 2, then $O(ghg^{-1})$ is
 (a) 0 (b) 1 (c) 2 (d) 4
10. At any time, the total number of persons on earth who have shaken hands an odd number of times has to be
 (a) an even number (b) an odd number (c) a prime number (d) a perfect square
11. Which of the following are irrational numbers?
 (a) $\sqrt{2}$ (b) e (c) 10.2 (d) 1.25252525...
12. The function $f(x) = |x/(x+1)|$
 (a) is less than 1, for all x (b) equals $f(-x)$
 (c) equals $1 - f(1/x)$ (d) none of the above
- *13. The domain of the function $\log(\log \sin(x))$ is
 (a) $0 < x < \pi$ (b) $2n\pi < x < (2n + 1)\pi, n \in \mathbb{N}$
 (c) empty set (d) none of the above
- *14. The system of equations
 $x + 2y + 3z = 4$
 $x + \lambda y + 2z = 3$
 $x + 4y + \mu z = 3$
 has infinite number of solutions if
 (a) $\lambda = 2; \mu = 3$ (b) $\lambda = 2; \mu = 4$
 (c) $3\lambda = 2\mu$ (d) none of the above
- *15. Let R be a symmetric and transitive relation on a set A . Then
 (a) R is reflexive and hence an equivalence relation
 (b) R is reflexive and hence a partial order
 (c) R is not reflexive and hence not an equivalence relation
 (d) none of the above
- *16. The number of elements in the power set of the set $\{\{\{\}\}, 1, \{2, 3\}\}$ is
 (a) 2 (b) 4 (c) 8 (d) 3
- *17. If $4(\log_9 3) + 9(\log_2 4) = 10(\log_x 81)$, then x is
 (a) 2 (b) e
 (c) 7 (d) none of the above
- *18. The length of the longest pole that can be made inside a hall of length 18m, breadth 6m, and height 4.5m is
 (a) 17.5m (b) 19.5m (c) 20m (d) 18.25m

191. The minimum number of bits required to represent a character from ASCII code set is
 (a) 2 (b) 5 (c) 7 (d) 8

192. Consider the following program fragment

```

DELAY: LXI H, 0010H
LOOP:  DCX H
      MOV A, L
      ORA H
      XRA A
      JNZ LOOP
      RET
    
```

The number of times LOOP will be executed is

- (a) 16 (b) 10 (c) 1 (d) infinite

193.

```

8000: START: LXI H, 0001H
          LXI D, 8010H
          XCHG
          DCX D
          JZ 800C
          PCHL
          800 C: JMP 8000
          NOP
          HLT
    
```

Referring to the above program, which of the following statements is true?

- (a) The program will loop infinitely
 (b) The program will reach halt state after the first pass
 (c) The program will reach halt state after 8010h times
 (d) None of the above

194. S0 and S1 pins are used for

- (a) serial communication (b) indicating the processor's status
 (c) acknowledging the interrupt (d) none of the above

195. Pick out the matching pair.

- (a) READY; RIM (b) HOLD; DMA
 (c) SID; SIM (d) S0, S1; Wait states

197. Consider the following program:

```

          ORG 8000H
START:  LXI H, 8000H
          MOVE A, L
          ADD H
          JM XYZ
          RST 0
    
```

```

block
    MVI C, 05H ; count = 5
LOOP : MOV A, M
      STAX B ; block copy
      INX X
      INX H
      DCR C
      JNZ LOOP
      HLT

```

- (a) JNZ instruction is used instead of JZ
 (b) C register is used as counter
 (c) the starting address of the destination block is altered as 9005H
 (d) DCR C instruction will not affect zero flag
81. RST 3 instruction will cause the processor to branch to the location
 (a) 0000h (b) 0018h (c) 0024h (d) 8018h
82. Which one of the following interrupts is non-maskable?
 (a) TRAP (b) RST 7.5 (c) INTR (d) RST 6.5
83. Which one of the following instructions will never affect the zero flag?
 (a) DCR reg (b) ORA reg (c) DCX rp (d) XRA reg
84. The contents of the A15-A8 (higher order address lines) while executing "IN addr" instruction are
 (a) same as the contents of A7-A0 (b) irrelevant
 (c) all bits reset (i.e. 00h) (d) all bits set (i.e. FFh)
85. Which of the following peripheral ICs is used to interface keyboard and display?
 (a) 8251 (b) 8279 (c) 8259 (d) 8253
86. The only interrupt that is edge-triggered is
 (a) INTR (b) TRAP (c) RST 7.5 (d) RST 5.5
87. Which one of the following instructions may be used to clear the accumulator content (i.e. A = 00h) irrespective of its initial value?
 (a) CLR A (b) ORA A (c) SUB A (d) MOV A, 00h
88. The execution of RST n instruction causes the stack pointer to
 (a) increment by two (b) decrement by two
 (c) remain unaffected (d) none of the above
89. The stack is nothing but a set of
 (a) reserved ROM address space (b) reserved RAM address space
 (c) reserved I/O address space (d) none of the above
90. The instruction used to shift right the accumulator contents by one bit through the carry flag bit is
 (a) RLC (b) RAL (c) RRC (d) RAR

- *19. Six x's have to be placed in the squares in the adjacent figure, such that each row contains at least one x. This can be done in
 (a) 160 ways (b) 180 ways
 (c) 170 ways (d) 26 ways
- *20. Out of 100 students, 10 students used to drink milk(M), coffee(C) and tea(T); 20 M and C; 30 C and T; 25 M and T; 12 M only; 5 C only and 8 T only. The number of students who did not drink any of these is
 (a) 18 (b) 24 (c) 20 (d) 16
21. Given the relation $R = \{(1, 2), (2, 3)\}$. The minimum number of ordered pairs that must be added to this set so that the enlarged relation is reflexive, symmetric and transitive is
 (a) 4 (b) 5 (c) 6 (d) 7
22. A box contains 2 black, 4 white and 3 red balls. One ball is drawn at random from the box and kept aside. From the remaining balls in the box, another ball is drawn at random and kept beside the first. This process is repeated till all the balls are drawn from the box. The probability that the balls drawn are in the sequence 2 black, 4 white, and 3 red is
 (a) 1/1260 (b) 17/1260 (c) 7/1260 (d) 13/1260
23. The range of the function $f(x) = x^2 / (1 + x^2)$ is
 (a) $(-\infty, +\infty)$ (b) $(0, \infty)$ (c) $(-\infty, 0]$ (d) $[0, 1)$
24. In calculating the mean and variance of 10 readings, a student wrongly used 52 instead of the correct figure 25. If the mean he obtained was 45, then the correct mean is
 (a) 47.3 (b) 43.7 (c) 42.3 (d) impossible to find
25. Refer Qn. 24. If the variance he obtained was 16, then the correct variance is
 (a) 43.8 (b) 47.3
 (c) 42.3 (d) impossible to find
- *26. If ${}^nC_{r-1} = 36$; ${}^nC_r = 84$ and ${}^nC_{r+1} = 126$, then the value of 'r' is
 (a) 9 (b) 6 (c) 5 (d) 3
27. In the interval $[0, \pi]$, the equation $x = \cos(x)$ has
 (a) no solution (b) exactly one solution
 (c) exactly two solutions (d) an infinite number of solutions
- *28. Ten different letters are given. Five letter words are formed from these given letters. The number of words having at least one letter repeated is
 (a) 99748 (b) 87882 (c) 92182 (d) 69760
- *29. The value of the expression ${}^{47}C_4 + \sum_{j=1}^5 ({}^{52-j}C_3)$ is equal to
 (a) $47! / 52!$ (b) $46! / 52!$ (c) ${}^{52}C_4$ (d) ${}^{52}C_{47}$
- *30. The rank of the following $(n + 1) \times (n + 1)$ matrix, where a is a real number is

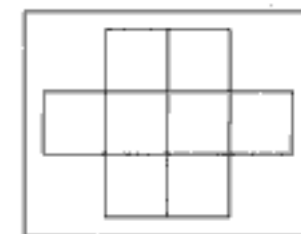

Fig. 4.1

$$\begin{pmatrix} 1 & a & a^2 & \dots & a^n \\ 1 & a & a^2 & \dots & a^n \\ \cdot & \cdot & \cdot & & \\ \cdot & \cdot & \cdot & & \\ 1 & a & a^2 & \dots & a^n \end{pmatrix}$$

- (a) 1 (b) 2
 (c) n (d) dependent on the value of a .
31. Let 'S' be the standard deviation of 'n' numbers. If each of the 'n' numbers is multiplied by a constant C, then the new standard deviation will be
 (a) $C \times S$ (b) $S\sqrt{C}$ (c) S (d) none of the above
32. Let A be a finite set of size 'n'. The number of elements in the power set of $A \times A$ is
 (a) 2^{2^n} (b) 2^{n^2} (c) $(2^n)^2$ (d) $(2^2)^n$
33. Probability of an event A happening is 0.4. Probability that in 3 independent trials, event A happens at least once is
 (a) 0.064 (b) 0.144 (c) 0.784 (d) 0.4
34. If x, y are two real numbers such that $x > 0$ and $xy = 1$, then $x + y$ can't be less than
 (a) 1.5 (b) 1.9 (c) 1.75 (d) 2.0
35. Let $f(x + y) = f(x) + f(y)$, for all x, y. If $f(x)$ is continuous at $x = 0$, then
 (a) f is continuous at all points
 (b) the number of points of discontinuity of f can't be infinite
 (c) the number of points of discontinuity of f must be infinite
 (d) none of the above.
36. Let $f(x + y) = f(x)f(y)$, for all x, y. If $f(5) = 2$ and $f'(0) = 3$, Then $f'(5)$ is equal to
 (a) 1 (b) 5 (c) 6 (d) -1
37. In numerical methods, accuracy refers to the
 (a) number of significant figures representing a quantity
 (b) spread in repeated readings of an instrument in measuring a particular physical quantity
 (c) proximity of an approximate number or measurement to the true value it is supposed to represent
 (d) all of the above
38. Suppose A_1, A_2, \dots, A_{30} are 30 sets, each with 5 elements, and B_1, B_2, \dots, B_n are 'n' sets, each with 3 elements.
 Let $\bigcup_{i=1}^{30} A_i = \bigcup_{j=1}^n B_j = S$.
 Each element of S, belongs to exactly 10 of the A_i 's and to exactly 9 of the B_j 's. Then 'n' is
 (a) 25 (b) 45 (c) 40 (d) 20

```
161. MVI B, 00
      MVI A, 1cH
      DCR B
      DAA
      STA TEMP
      HLT
```

The content of the TEMP location after the execution of the above program is
 (a) 1Ch (b) 22h (c) 82h (d) 12h

162. Which of the following instructions requires the most number of T-states?
 (a) MOV A, B (b) MOV A, M (c) LDAX B (d) DAD D
163. Consider the following program. Assume that the program is stored in R/W memory.
- | | |
|--------------------|------------------------|
| Initial condition: | (A000H) = 00H |
| 8000: | 31 07 80 LXI SP, 8007H |
| 8003: | 3E 76 MVI A, 76H |
| 8005: | F5 PUSH PSW |
| 8006: | 3A 00 A0 LDA A000H |
| 8009: | F1 POP PSW |
| 800A: | 3A 00 A0 STA A000H |
| 800D: | 76 HLT |
- The content of the location A000H after the execution of the above program is
 (a) 76h (b) 00h (c) FFh (d) 55h
164. The 8085 μP enters into wait state after the recognition of
 (a) HOLD (b) *READY (c) *RESET-IN (d) INTR
165. Maximum number of I/O devices that can be addressed by Intel 8085 is
 (a) 65,536 (b) 255 (c) 512 (d) 256
166. The μP may be made to exit from HALT state by asserting
 (a) RESET (b) any of the five interrupt lines
 (c) READY line (d) option (a) or option (b) or HOLD line
167. The number of RAM chips of size (256 K \times 1) required to build a 1 Mbyte memory is
 (a) 8 (b) 32 (c) 10 (d) 24
- 168.
- | | |
|-------|------------------------|
| 8000: | 31 07 80 LXI SP, 8007H |
| 8003: | AF XRA A |
| 8004: | FE 0A CPI 0AH |
| 8006: | D8 RC |
| 8007: | 0C INR C |
| 8008: | 80 ADD B |
| 8009: | 02 STAX B |

2. A subtractor is not usually present in a computer because
- it is expensive
 - it is not possible to design it
 - the adder will take care of subtraction
 - none of the above
3. Let $a_n a_{n-1} \dots a_1 a_0$ be the binary representation of an integer b . The integer b is divisible by 3 if
- the number of one's is divisible by 3
 - the number of one's is divisible by 3, but not by 9
 - the number of zeroes is divisible by 3
 - the difference of alternate sum, i.e., $(a_0 + a_2 + \dots) - (a_1 + a_3 + \dots)$ is divisible by 3
4. Which of the following 4-bit numbers equals its 2's complement?
- 1010
 - 0101
 - 1000
 - No such number exists
5. Which of the following 4-bit numbers equals its 1's complement?
- 1010
 - 1000
 - No such number exists
 - None of the above
6. FFFF will be the last memory location in a memory of size
- 1 k
 - 16 k
 - 32 k
 - 64 k
7. If you want to design a boundary counter, you should prefer a flip-flop of
- D-type
 - SR-type
 - latch
 - JK type
8. Suppose the largest n -bit binary number requires ' d ' digits in decimal representation. Which of the following relations between ' n ' and ' d ' is approximately correct?
- $d = 2^n$
 - $n = 2^d$
 - $d < n \log_{10} 2$
 - $d > n \log_{10} 2$
9. A computer uses 8-digit mantissa and 2-digit exponent. If $a = 0.052$ and $b = 28E + 11$, then $b+a-b$ will
- result in an overflow error
 - result in an underflow error
 - be 0
 - be $5.28E+11$
10. In Question 129, ' a ' will actually be stored as (the ' $'$ ' is separating the mantissa and the exponent)
- 00000000/00
 - 05200000/00
 - 52000000/-09
 - 52000000/-01
11. Which of the following binary numbers are not divisible by 4?
- 10101010101010
 - 100101100
 - 1110001110001
 - 1111000011
12. A computer with a 32-bit wide data bus uses $4 K \times 8$ static RAM memory chips. The smallest memory this computer can have is
- 32 Kb
 - 16 Kb
 - 8 Kb
 - 24 Kb

39. Which of the following remarks about an ill-conditioned system of equations are true?
- Small change in coefficient will result in large change in solution.
 - A wide range of solutions can approximately satisfy the equations.
 - If slope of two lines are almost same, they make up an ill-conditioned system of equations.
 - None of the above.
- *40. If the cube roots of unity are $1, \omega, \omega^2$, then the roots of the equation $(x-1)^3 + 8 = 0$, are
- $-1, 1 + 2\omega, 1 + 2\omega^2$
 - $1, 1 - 2\omega, 1 - 2\omega^2$
 - $-1, 1 - 2\omega, 1 - 2\omega^2$
 - $-1, -1 + 2\omega, -1 + 2\omega^2$
- *41. $f(x)$ and $g(x)$ are two functions differentiable in $[0, 1]$ such that $f(0) = 2; g(0) = 0; f(1) = 6;$ and $g(1) = 2$. Then there must exist a constant C in
- $(0, 1)$, such that $f'(C) = 2g'(C)$
 - $[0, 1]$, such that $f'(C) = 2g'(C)$
 - $(0, 1)$, such that $2f'(C) = g'(C)$
 - $[0, 1]$, such that $2f'(C) = g'(C)$
- *42. Let f be a one-to-one function with domain $\{x, y, z\}$ and range $\{1, 2, 3\}$. It is given that exactly one of the following statements is true and the remaining 2 are false:
- $$f(x) = 1$$
- $$f(y) \neq 1$$
- $$f(z) \neq 2$$
- Then $f^{-1}(1)$ equals
- 2
 - x
 - y
 - z
- *43. Let f be a twice differentiable function such that $f''(x) = -f(x)$ and $f'(x) = g(x)$. Let $h(x) = (f(x))^2 + (g(x))^2$. If $h(5) = 11$, then $h(10)$ is
- 8
 - 9
 - 10
 - 11
44. If A and B are two events such that $P(A) > 0$ and $P(B) \neq 1$, then $P(\bar{A}/\bar{B})$ equals
- $(1 - P(A \cup B)) / P(\bar{B})$
 - $(1 - P(A \cup B)) / P(B)$
 - $(1 - P(A \cap B)) / P(\bar{B})$
 - $(1 - P(A \cap B)) / P(B)$
- *45. i^i , where i is $\sqrt{-1}$, is
- a pure imaginary number
 - a complex number
 - an integer
 - a real number
46. If p, q, r are three real numbers, then
- $\max(p, q) < \max(p, q, r)$
 - $\max(p, q) = (p + q + |p - q|) / 2$
 - $\max(p, q) < \min(p, q, r)$
 - none of the above
- *47. The number of 1's in the binary representation of $(3 \times 4096 + 15 \times 256 + 5 \times 16 + 3)$ is
- 8
 - 9
 - 10
 - 12

48. A determinant is chosen at random from the set of all determinants of order 2 with each element either 0 or 1 only. The probability that the value of the chosen determinant is positive is
 (a) 1/2 (b) 2/7 (c) 3/16 (d) 7/16
49. The number of permutations of 'n' different things taken not more than 'r' at a time, with repetitions being allowed, is
 (a) $(n^r - 1) / (n - 1)$ (b) $(n^r - 1) / (n - 1)!$
 (c) $n(n^r - 1) / (n - 1)$ (d) $(n^r - 1) / n!$
50. A relation R is defined in $N \times N$, such that $(a, b) R (c, d)$ iff $a + d = b + c$. The relation R is
 (a) reflexive but not transitive (b) reflexive and transitive, but not symmetric
 (c) an equivalence relation (d) a partial order
51. If $\log_5 10 = \log_7 x(\log_n m)$, then the values of x, m, n are
 (a) 10, 7, 5 (b) -1, 2, 3 (c) 7, 5, 3 (d) 7, 5, 8
52. If $\sqrt{5} + \sqrt{7} + i$, is one of the roots of the equation $f(x) = 0$ with rational coefficients, then the degree of the given equation can't be less than
 (a) 5 (b) 6 (c) 7 (d) 8
53. Consider the equation $x^7 - 2x^5 + 7x^4 + x^3 - 9 = 0$. The number of imaginary roots will be at least
 (a) 2 (b) 3 (c) 4 (d) 5
54. If $f(a)$ and $f(b)$ are of the same sign, then the equation $f(x) = 0$
 (a) has either no root or even number of roots between a and b
 (b) must have at least one root between a and b
 (c) has either no root or odd number of roots between a and b
 (d) has odd number of roots between a and b
55. The equation $x^5 + x^3 - 8x - 5 = 0$ has
 (a) exactly 3 real roots and 2 complex roots
 (b) no complex root
 (c) no real root
 (d) exactly 2 real roots and 3 complex roots
56. Any polynomial of even degree in which the last term is negative and the coefficient of the highest power is positive, has at least
 (a) 2 positive roots (b) 2 negative roots
 (c) 1 positive root and 1 negative root (d) 2 positive and 1 negative root
57. When the polynomial $f(x)$ is divided by $(x - \alpha)(x - \beta)$, $\alpha \neq \beta$ then the remainder is given by
 (a) $((x - \beta)f(\alpha) - (x - \alpha)f(\beta)) / (\alpha - \beta)$ (b) $((x - \alpha)f(\beta) - (x - \beta)f(\alpha)) / (\alpha - \beta)$
 (c) $(f(\alpha) - f(\beta)) / (\alpha - \beta)$ (d) $((x - \alpha)f(\beta) + (x - \beta)f(\alpha)) / (\alpha - \beta)$
58. $\log 0$ is
 (a) $-\infty$ (b) $+\infty$
 (c) depends on the base (d) undefined

113. An assembler that runs on one machine but produces machine code for another machine is called
 (a) simulator (b) emulator (c) cross-assembler (d) boot-strap loader
114. When even-parity ASCII text is transmitted asynchronously at a rate of 10 characters per sec over a 110-bps line, what percentage of the received bits actually contain data (as opposed to over head)?
 (a) 7/11 (b) 8/11 (c) 700/11 (d) 80/11
115. Which of the following is not typically found in the status register of a microprocessor?
 (a) Overflow (b) Zero result (c) Negative result (d) None of the above
116. The output F, of the circuit given in Fig. 8.8 is given by

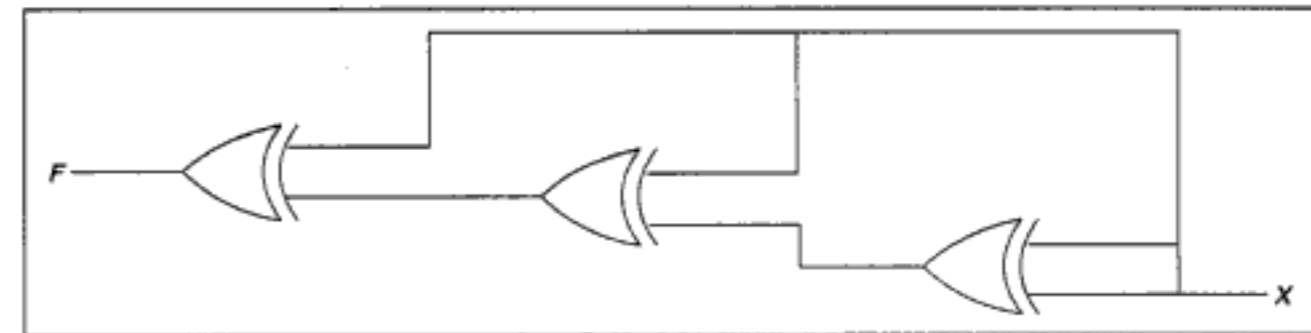

Fig. 8.8

- (a) 1 (b) 0 (c) X (d) X'
117. Most of the digital computers do not have floating-point hardware because
 (a) it is costly
 (b) it is slower than software
 (c) floating-point addition cannot be performed by hardware.
 (d) none of the above
118. 'n' flip-flops will divide the clock frequency by a factor of
 (a) n^2 (b) n (c) 2^n (d) $\log(n)$
119. A toggle operation cannot be performed using a single
 (a) NOR gate (b) AND gate (c) NAND gate (d) XOR gate
120. Micro program is
 (a) the name of a source program in micro computers
 (b) the set of instructions indicating the primitive operations in a system
 (c) a primitive form of macros used in assembly language programming
 (d) a program of very small size
121. The three main components of a digital computer system are
 (a) memory, I/O, DMA (b) ALU, CPU, memory
 (c) memory, CPU, I/O (d) control circuits, ALU, registers

95. The exponent of a floating-point number is represented in excess-N code so that
- the dynamic range is large
 - the precision is high
 - the smallest number is represented by all zeroes
 - overflow is avoided
96. On receiving an interrupt from an I/O device, the CPU
- halts for a predetermined time
 - hands over control of address bus and data bus to the interrupting device
 - branches off to the interrupt service routine immediately
 - branches off to the interrupt service routine after completion of the current instruction.
- *97. The Karnaugh map for the Boolean function F of 4 Boolean variables is given in Fig. 8.6. A, B, C are don't care conditions. What values of A, B, C , will result in the minimal expression?
- $A = B = C = 1$
 - $B = C = 1; A = 0$
 - $A = C = 1; B = 0$
 - $A = B = 1; C = 0$
- | | | | |
|---|---|---|--|
| | | A | |
| | 1 | 1 | |
| 1 | B | C | |
| | | 1 | |
- Fig. 8.6
98. In serial communication, an extra clock is needed
- to synchronize the devices
 - for programmed baud rate control
 - to make efficient use of RS-232
 - none of the above
99. If negative numbers are stored in 2's complement form, the range of numbers that can be stored in 8 bits is
- 128 to +128
 - 128 to +127
 - 127 to +128
 - 127 to +127
100. If SUB A, B means $B - A$, then SUB 4(R0), *5(R1) means (X) means content of register or memory location X)
- $((R1) + 5) - (4 * (R0))$
 - $((R1) + 5) - ((R0) + 4)$
 - $((R1) + 5) - (4 * (R0))$
 - $((R1) + 4) - (R0 + 4)$
- *101. A computer uses a floating-point representation comprising a signed magnitude fractional mantissa and an excess-16 base-8 exponent. What decimal number is represented by a floating-point number whose exponent is 10011, mantissa 101000, and the sign bit set?
- 6250
 - 20480
 - 320
 - 0.00122
102. The binary equivalent of the Gray code 11100 is
- 10111
 - 00111
 - 01011
 - 10101
- *103. The minimum number of 2-input NAND gates required to implement the function $F = (x' + y')(z + w)$ is
- 3
 - 4
 - 5
 - 6

- *59. If a_1, a_2, \dots, a_n are the roots of the equation $x^n + nax - b = 0$, then $(a_1 - a_2)(a_1 - a_3) \dots (a_1 - a_n)$ equals
- $n(a + a_1^{n-1})$
 - $(a + a_1^{n-1})/n$
 - $n(a - a_1^{n-1})$
 - $(a - a_1^{n-1})/n$
60. The set of all natural numbers is not closed with respect to
- subtraction
 - division
 - addition
 - multiplication
- *61. If $|a - b| < n$ and $|b - c| < m$, then $|a - c|$ is
- $< n + m$
 - $< \text{maximum of } m, n$
 - $< \text{minimum of } m, n$
 - $< mn$
62. The domain of the function $1/\sqrt{(1-x)(x-2)}$ is
- $(1, \infty)$
 - $(1, 2)$
 - $(2, \infty)$
 - $(0, 2)$
- *63. A and B play a coin tossing game. They toss a coin alternately. The first one to get a head wins. If A starts, the probability of A winning is
- 1/3
 - 1/2
 - 2/3
 - 1/4
- *64. The number of trailing zeroes in 200! (i.e., factorial of 200) is
- 49
 - 40
 - 48
 - 52
- *65. The determinant of a matrix has 720 terms (in the unsimplified form). The order of the matrix is
- 5
 - 6
 - 7
 - 8
66. The error in using Simpson's rule is of the order
- h^2
 - h^3
 - h^4
 - h^5
- *67. The domain of the function $1/\sqrt{|x| - x}$ is
- $(-\infty, 0)$
 - $(0, \infty)$
 - $(0, x)$
 - $(0, 1)$
- *68. A bag contains 10 white balls and 15 black balls. Two balls are drawn in succession. The probability that one of them is black and the other white is
- 2/3
 - 4/5
 - 1/2
 - 1/3
- *69. The iteration formula to find the square root of a positive real number b , using the Newton-Raphson method is
- $x_{k+1} = 3(x_k + b) / 2x_k$
 - $x_{k+1} = (x_k^2 + b) / 2x_k$
 - $x_{k+1} = x_k - 2x_k / (x_k^2 + b)$
 - none of the above
70. If $|x - 1| + |x - 2| + |x - 3| \geq 6$, then
- $x \leq 0$ or $x \geq 4$
 - $1 \leq x \leq 3$
 - $x \leq 3$
 - $x \geq 1$
71. The number of real roots of the equation $|x|^2 - 3|x| + 2 = 0$ is
- 1
 - 2
 - 3
 - 4
- *72. $-20\sqrt{-\sqrt{20 - \sqrt{\dots}}}$ equals
- 4
 - 8
 - 20
 - 35

- *73. Two events A and B have probabilities 0.25 and 0.5 respectively. The probability that both A and B occur simultaneously is 0.14. Then the probability that neither A nor B occurs is
 (a) 0.25 (b) 0.75 (c) 0.39 (d) 0.11
- *74. A function $f(x)$ differentiable in the interval $0 \leq x \leq 5$, is such that $f(0) = 4$ and $f(5) = -1$. If $g(x) = f(x) / (x + 1)$, then there exists some constant C , $0 < C < 5$ such that $g'(C)$ equals
 (a) $-2/5$ (b) $2/5$ (c) $-3/5$ (d) $-5/6$
75. Let S be an infinite set and S_1, S_2, \dots, S_n be sets such that $S_1 \cup S_2 \cup \dots \cup S_n = S$. Then,
 (a) at least one of the sets S_i is a finite set
 (b) not more than one of the sets S_i can be finite
 (c) at least one of the sets S_i should be infinite
 (d) not more than one of the sets S_i can be infinite
- *76. Let A and B be sets with cardinalities ' m ' and ' n ' respectively. The number of possible one to one mappings (injections) from A to B , when $m < n$, is
 (a) m^n (b) ${}^m C_n$ (c) ${}^n P_m$ (d) ${}^m P_2$
- *77. Choose the correct answers.
 The set $\{1, 2, 3\}$ is equal to
 (a) $\{2, 1, 3\}$ (b) $\{3, 2, 1\}$ (c) $\{1, 2, 3, 4\}$ (d) $\{1, 2, 3, 1\}$
78. Let $A = \{1, \{2\}, 3\}$.
 Choose the correct option.
 (a) $1 \in A$ (b) $\{2\} \subset A$ (c) $\phi \in A$ (d) $\phi \subset A$
79. Choose the correct answers.
 If A, B, C are three sets, then
 (a) $A \cup (B \cap C) = (A \cup B) \cap (A \cup C)$ (b) $(A - B) - C = (A - C) - (B - C)$
 (c) $(A \times B) \times C = A \times (B \times C)$ (d) $A \times (B \cup C) = (A \times B) \cup (A \times C)$
- *80. In the set of integers, a relation R is defined as aRb , if and only if $b = |a|$. This relation is
 (a) reflexive (b) irreflexive (c) symmetric (d) anti-symmetric
- *81. Let $S = \{1, 2, 3, 4\}$. A relation R defined in S as, $R = \{(1, 2), (4, 3), (2, 2), (2, 1), (3, 1)\}$ is
 (a) transitive (b) symmetric (c) anti-symmetric (d) none of the above
- *82. Let $A = \{1, 2, 3\}$. Which of the following relations are functions (mappings)?
 (a) $\{(1, 2), (2, 3), (1, 3)\}$ (b) $\{(1, 2), (2, 2), (3, 2)\}$
 (c) $\{(1, 2), (2, 1), (3, 3)\}$ (d) $\{(1, 2), (2, 3)\}$
83. Consider the mapping $f: X \rightarrow Y$. f is a bijection if and only if
 (a) $f(x) = f(y) \Rightarrow x = y$, for all x, y (b) range of f is Y
 (c) both (a) and (b) are true (d) the co-domain equals the range
84. For a function to be invertible, it has to be
 (a) one-one (b) onto
 (c) both one-one and onto (d) none of the above
85. The advantages of partial pivoting in the solution of a system of equations are
 (a) division by zero can be avoided
84. The most relevant addressing mode to write position independent code is
 (a) direct mode (b) indirect mode (c) relative mode (d) indexed mode
85. Which of the following are CISC machines?
 (a) IBM 360 (b) 80386 (c) 68030 (d) none of the above
86. Which of the following rules regarding the addition of 2 given numbers is correct, if negative numbers are represented in 2's complement form?
 (a) Add sign bit and discard carry, if any.
 (b) Add sign bit and add carry, if any.
 (c) Don't add sign bit and discard carry, if any.
 (d) Don't add sign bit and add carry, if any.
87. When INTR is encountered, the processor branches to the memory location, which is
 (a) 0024H
 (b) determined by the 'call address' instruction issued by the I/O device
 (c) determined by the 'RST n' instruction issued by the I/O device
 (d) all of the above
88. The advantage of a single bus over a multi-bus is the
 (a) low cost (b) flexibility in attaching peripheral devices
 (c) high operating speed (d) all of the above
- *89. The number of possible Boolean functions that can be defined for n Boolean variables over n -valued Boolean algebra is
 (a) 2^{2^n} (b) 2^{n^2} (c) n^{2^n} (d) n^{n^n}
90. The ASCII code 56, represents the character
 (a) V (b) 8 (c) a (d) carriage return
91. Parallel printer uses
 (a) RS-232C interface (b) centronics interface
 (c) hand-shake mode (d) synchronous data transfer mode
92. A microprogrammed control unit
 (a) is faster than a hard-wired control unit
 (b) facilitates easy implementation of new instructions
 (c) is useful when very small programs are to be run
 (d) usually refers to the control unit of a microprocessor
93. Which of the following are typical characteristics of a RISC machine?
 (a) Instruction taking multiple cycles
 (b) Highly pipelined
 (c) Instructions interpreted by microprograms
 (d) Multiple register sets
- *94. The working of a staircase switch is a typical example of the logical operation
 (a) OR (b) NOR (c) Exclusive-OR (d) Exclusive-NOR

73. In which of the following instructions bus idle situation occurs?
 (a) EI (b) DAD rp (c) INX H (d) DAA
- *74. Any instruction should have at least
 (a) 2 operands (b) 1 operand (c) 3 operands (d) none of the above
- *75. Consider the circuit in Fig. 8.5.

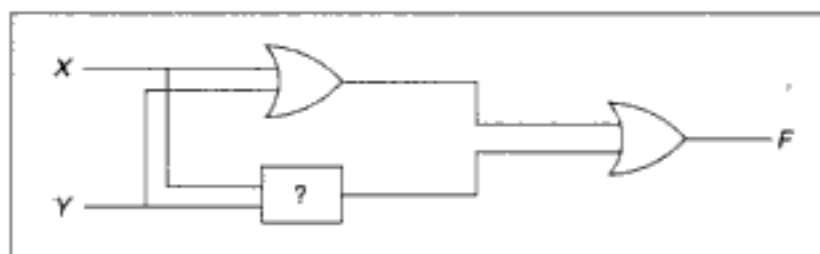

Fig. 8.5

In order to make it a tautology the '?' marked box should be replaced by

- (a) an OR gate (b) an AND gate (c) a NAND gate (d) a NOR gate
- *76. If the cache needs an access time of 20 ns and the main memory 120 ns, then the average access time of a CPU is (assume hit-ratio is 80%)
 (a) 30 ns (b) 40 ns (c) 35 ns (d) 45 ns
77. The number of clock cycles necessary to complete 1 fetch cycle in 8085 (excluding wait state) is
 (a) 3 or 4 (b) 4 or 5 (c) 4 or 6 (d) 3 or 5
- *78. The seek time of a disk is 30 ms. It rotates at the rate of 30 rotations per second. Each track has a capacity of 300 words. The access time is approximately
 (a) 47 ms (b) 50 ms (c) 60 ms (d) 62 ms
79. Motorola's 68040 is comparable to
 (a) 8085 (b) 80286 (c) 80386 (d) 80486
- *80. The possible number of Boolean functions of 3 variables X, Y and Z such that $f(X, Y, Z) = f(X', Y', Z')$ is
 (a) 8 (b) 16 (c) 64 (d) 32
81. Which of the following interrupt is both level and edge sensitive?
 (a) RST 5.5 (b) INTR (c) RST 7.5 (d) TRAP
82. The difference between 80486 and 80386 is/are
 (a) presence of floating point co-processor
 (b) speed of operation
 (c) presence of 8 K cache on chip
 (d) presence of memory controller
83. The addressing mode used in the instruction PUSH B is
 (a) direct (b) register (c) register indirect (d) immediate

- (b) round-off errors can be minimized
 (c) ill-conditioned system can be handled efficiently
 (d) none of the above
- *86. Choose the correct statements.
 (a) Any 7 integers chosen from 1 to 12 should have at least 2 of them summing up to 13.
 (b) Any 11 integers chosen from 1 to 20 should have at least 2 numbers, such that one is a multiple of the other.
 (c) 10 integers, 1 to 10 arranged at random in a circle should have at least 3 successive numbers summing up to greater than 16.
 (d) None of the above.
87. Choose the correct statements.
 (a) If two graphs $G1$ and $G2$ are isomorphic, then they should have the same number of vertices and edges.
 (b) If two graphs have the same number of nodes and edges, they have to be isomorphic.
 (c) Loops can't be present in an isomorphic graph.
 (d) None of the above.
88. In any undirected graph, the sum of degrees of all the nodes
 (a) must be even
 (b) is twice the number of edges
 (c) must be odd
 (d) need not be even
89. $(PVQ) \wedge (P \rightarrow R) \wedge (Q \rightarrow S)$ is equivalent to
 (a) $S \wedge R$ (b) $S \rightarrow R$ (c) $S \vee R$ (d) none of the above
90. Which of the following are tautologies?
 (a) $((PVQ) \wedge Q) \leftrightarrow Q$ (b) $(P \vee (P \rightarrow Q)) \rightarrow P$
 (c) $((PVQ) \wedge P) \rightarrow Q$ (d) $((PVQ) \wedge \neg P) \rightarrow Q$
91. Identify the valid conclusion from the premises $P \vee Q, Q \rightarrow R, P \rightarrow M, \neg M$
 (a) $P \wedge (Q \vee R)$ (b) $P \wedge (Q \wedge R)$ (c) $R \wedge (P \vee Q)$ (d) $Q \wedge (P \vee R)$
92. T is a graph with ' n ' vertices. If T is connected and has exactly $n-1$ edges, then
 (a) T is a tree
 (b) T contains no cycles
 (c) every pair of vertices in T is connected by exactly one path
 (d) the addition of a new edge will create a cycle.
- *93. If one has to obtain the roots of $x^2 - 2x + \log 2 = 0$ to four decimal places, $\log 2$ should be given to the accuracy of approximately
 (a) 6×10^{-5} (b) 7×10^{-6} (c) 8×10^{-5} (d) 9×10^{-7}
- *94. Choose the incorrect statement(s).
 (a) The determinant of a matrix equals the sum of its eigen values.
 (b) A matrix satisfies its characteristic equation.

- (c) The sum of the principal diagonal elements of a matrix equals the sum of its eigen values.
- (d) If a row of a matrix is same as one of its columns, its determinant value is 0.

- *95.** M is a square matrix of order ' n ' and its determinant value is 5. If all the elements of M are multiplied by 2, its determinant value becomes 40. The value of ' n ' is
 (a) 2 (b) 3 (c) 4 (d) 5
- 96.** In a computer an n -digit integer $a_n a_{n-1} \dots a_1$ is represented as $a_n a_{n-1} \dots a_{r+1} 00 \dots 0$. The error e is
 (a) $0 \leq e \leq 10^{r-1}$ (b) $1 \leq e \leq 10^r - 1$ (c) $0 \leq e \leq 10^{r-1} - 1$ (d) $0 \leq e \leq 10^{r+1} - 1$
- 97.** $1 - x^2/2! + x^4/4! - \dots + (-1)^n x^{2n}/2n! + \dots$ is the expansion of
 (a) e^x (b) $\log x$ (c) $\cos x$ (d) $\sin x$
- *98.** In the previous question, for 5-digit accuracy, if $|x| < \pi/2$, the number of terms in the series that should be considered is
 (a) 5 (b) 7 (c) 9 (d) 10
- 99.** Which of the following methods gives the least error when e^x is integrated from 0 to 0.4?
 (a) Trapezoidal rule with the interval width as 0.2
 (b) Trapezoidal rule with the interval width as 0.1
 (c) Simpson's 1/3 rule with the interval width as 0.1
 (d) Simpson's 1/3 rule with the interval width as 0.2
- 100.** Which of the following laws doesn't hold good in finite precision floating point arithmetic?
 (a) $a \times b = b \times a$ (b) $(a + b) + c = a + (b + c)$
 (c) $a \times (b + c) = a \times b + a \times c$ (d) $a + a = 2 \times a$
- 101.** Surplus variables are usually introduced in an LPP model
 (a) if the demand is less than the available resource
 (b) if the available resource is less than the demand
 (c) if the demand is same as the available resource
 (d) while solving the dual of the given primal
- *102.** In an LPP model in its standard form, three of the constraints are

$$x_1 + x_2 \leq 2$$

$$2x_1 + 2x_2 \leq 3$$

$$3x_1 + 3x_2 \leq 8$$
 Removal of which of the constraints will not affect the optimality?
 (a) II and III (b) I and II (c) I and III (d) I only
- 103.** An LPP having 2 optimal solutions must have
 (a) more than 3 constraints
 (b) more than 2 optimal solutions
 (c) even number of constraints
 (d) none of the above

- *62.** How many 2-input multiplexers are required to construct a 2^{10} -input multiplexer?
 (a) 1023 (b) 31 (c) 10 (d) 127
- *63.** Let A be a set having ' n ' elements. The number of binary operations that can be defined on A is
 (a) n^{n^2} (b) 2^{n^2} (c) n^{2^n} (d) 2^{2^n}
- *64.** The values of x and y , if $(x567)_8 + (2yx5)_8 = (71yx)_8$ is
 (a) 4, 3 (b) 3, 3 (c) 4, 4 (d) 4, 5
- *65.** A decimal number has 25 digits. The number of bits needed for its equivalent binary representation is, approximately,
 (a) 50 (b) 60 (c) 70 (d) 75
- *66.** The number of instructions needed to add ' n ' numbers and store the result in memory using only one address instructions is
 (a) n (b) $n - 1$ (c) $n + 1$ (d) independent of n
- *67.** The Boolean expression corresponding to the circuit in Fig. 8.4 is

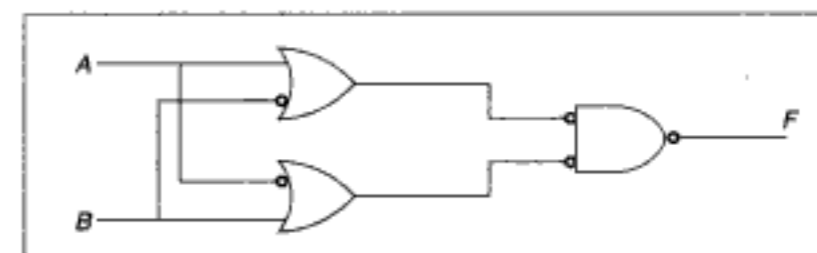

Fig. 8.4

- (a) a tautology (b) an inconsistency
 (c) independent of A (d) none of the above
- 68.** The clock of a microprocessor can be divided by 5 using a
 (a) 3 bit counter (b) 5 bit counter (c) mod 5 counter (d) mod 3 counter
- *69.** The minimal cover for the maximal compatibility classes $\{ae, acd, ad, bd\}$ is
 (a) ae, acd, ad (b) acd, ad, bd
 (c) ae, acd, bd (d) ae, ad, bd
- *70.** The values of a, x, y if 47×80 is the 10's complement of $yaya0$ are
 (a) 4, 3, 2 (b) 5, 4, 4 (c) 3, 4, 5 (d) 2, 4, 5
- 71.** The reasons for the presence of ALE pin in 8085, but not in 6800 is that
 (a) 8085 uses I/O mapped I/O, whereas 6800 uses memory mapped I/O
 (b) 8085 has 5 interrupt lines, whereas 6800 has only 2
 (c) 8085 has multiplexed bus, whereas 6800 doesn't have
 (d) none of the above
- *72.** If memory access takes 20 ns with cache and 110 ns without it, then the hit-ratio, (cache uses a 10 ns memory) is,
 (a) 93% (b) 90% (c) 87% (d) 88%

- *52. The XOR operator \oplus is
 (a) commutative (b) associative
 (c) distributive over AND operator (d) none of the above
53. Bubble memories are preferable to floppy disks because
 (a) of their higher transfer rate (b) the cost needed to store a bit is less
 (c) they consume less power (d) of their reliability
54. Addressing capability of 8086/88 is
 (a) 64 K (b) 512 K (c) 2 MB (d) 1 MB
55. The following circuit produces the output sequence

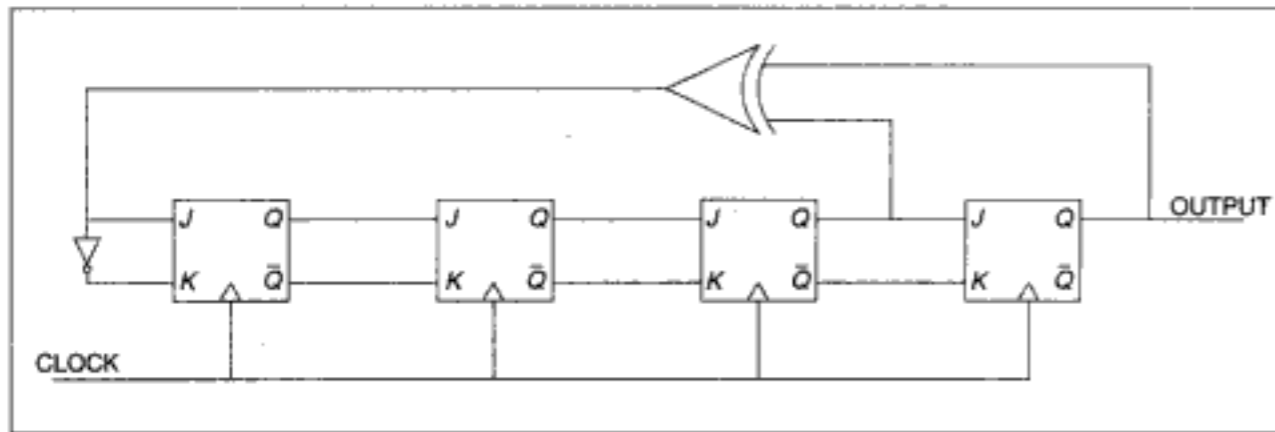

Fig. 8.3

- (a) 1111 1111 0000 0000 (b) 1111 0000 1111 0000
 (c) 1111 0001 0011 010 (d) 1010 1010 1010 1010
56. Which of the following units can be used to measure the speed of a computer?
 (a) SYPS (b) MIPS (c) BAUD (d) FLOPS
- *57. if $A \oplus B = C$ (\oplus stands for the XOR operator), then
 (a) $A \oplus B = B$ (b) $B \oplus C = A$
 (c) $A \oplus B \oplus C = 0$ (d) none of the above
58. Which of the following operation(s) is/are not closed as regards to computers?
 (a) Addition (b) Subtraction (c) Multiplication (d) Division
- *59. If $(11A1B)_8 = (12C9)_{16}$ (C stands for decimal 12), then the values of A and B are
 (a) 5, 1 (b) 7, 5 (c) 5, 7 (d) none of the above
- *60. The total number of possible Boolean functions involving ' n ' Boolean variables is
 (a) infinitely many (b) n^n (c) n^2 (d) none of the above
61. Which of the following architecture is/are not suitable for realizing SIMD?
 (a) Vector processor (b) Array processor
 (c) Von Neumann (d) All of the above

104. The number of iterations taken by simplex method for solving an LPP in its standard form, with ' m ' equations and ' n ' unknowns ($m < n$) can't exceed
 (a) mC_n (b) mP_n (c) nC_m (d) nP_m
105. In the solution of an LPP using simplex method, the current cost of the objective function must
 (a) increase in the next iteration
 (b) can't decrease in the next iteration
 (c) remain the same in the next iteration
 (d) correspond to one of the corners of the convex region bound by the constraining inequations
106. If the cost of the objective function (of an LPP in its standard form) which corresponds to one of the corners of the convex region bound by the constraints, is greater than the cost corresponding to all its adjacent corners, then
 (a) it is the optimal solution
 (b) simplex method enters a cycle
 (c) simplex method moves onto one of the adjacent corners
 (d) simplex method terminates
107. Revised simplex method
 (a) is conceptually same as the simplex method
 (b) is a version of simplex method ideal for implementation in computer
 (c) is a version of simplex method ideal for sensitivity analysis
 (d) uses recursion instead of iteration to solve a given LPP
108. The dual simplex method starts with a
 (a) feasible but super-optimal solution
 (b) feasible but sub-optimal solution
 (c) infeasible but super-optimal solution
 (d) infeasible but sub-optimal solution
109. Which of the following simplex based techniques are ideal for sensitivity analysis?
 (a) Revised simplex method (b) Parametric programming
 (c) Dual simplex method (d) Big-M method
110. Choose the correct statements.
 (a) It is computationally advantageous to solve a given LPP in its dual form, if the number of constraints in the primal form is more than the number of variables.
 (b) The cost of the (primal) objective function corresponding to a feasible solution can't be greater than, the cost of the (dual) objective function corresponding to any of its feasible solution.
 (c) It is computationally advantageous to solve a given LPP in its dual form, if the number of variables in the primal form is more than the number of constraints.

(d) The cost of the (primal) objective function corresponding to a feasible solution cannot be less than the cost of the (dual) objective function corresponding to any of its feasible solution.

- 111.** Choose the correct statement(s).
 (a) Addition of a new constraint to an LPP can never improve the optimal value
 (b) Addition of a new variable can never decrease the optimal value
 (c) Addition of a new constraint can never decrease the optimal value
 (d) Addition of a new variable can never improve the optimal value
- 112.** Changing the right hand side of the constraints and the coefficient of the cost function
 (a) can't destroy the optimality of the solution
 (b) can't destroy the feasibility of the solution
 (c) can destroy the optimality and feasibility of the solution
 (d) none of the above
- 113.** Let A be the set of all non-singular matrices over real numbers and let $*$ be the matrix multiplication operator. Then,
 (a) A is closed under $*$ but $\langle A, * \rangle$ is not a semi-group
 (b) $\langle A, * \rangle$ is a semi-group but not a monoid
 (c) $\langle A, * \rangle$ is a monoid but not a group
 (d) $\langle A, * \rangle$ is a group but not an abelian group
- 114.** Newton-Raphson method
 (a) is not efficient in handling multiple roots
 (b) has a slow rate of convergence
 (c) should not be preferred if there is a point of inflexion in the vicinity of the root
 (d) should not be preferred if the graph of the curve is almost parallel to the x -axis, in the vicinity of the root
- 115.** In the bisection method for finding the roots of an equation, the approximate relative error is always
 (a) greater than the relative error
 (b) equal to the relative error
 (c) less than the relative error
 (d) none of the above
- 116.** Trapezoidal rule gives the exact solution when the curve is
 (a) concave towards the base line
 (b) convex towards the base line
 (c) a straight line
 (d) none of the above
- 117.** If a function $y' = f(x)$ has an inverse function, then $f(x)$ can't be
 (a) symmetric about x -axis
 (b) an odd function
 (c) symmetric about y -axis
 (d) none of the above
- 118.** For what value of c , will the vector $i + cj$ be orthogonal to $2i - j$?
 (a) 0
 (b) 1
 (c) 2
 (d) 3
- *119.** The solution of the differential equation $y'' + 3y' + 2y = 0$, is of the form
 (a) $C_1e^x + C_2e^{2x}$
 (b) $C_1e^{-x} + C_2e^{3x}$
 (c) $C_1e^{-x} + C_2e^{-2x}$
 (d) $C_1e^{-2x} + C_2e^{-x}$

- *41.** The number of columns in a state table for a sequential circuit with ' m ' flip-flops and ' n ' input is
 (a) $m + n$
 (b) $m + 2n$
 (c) $2m + n$
 (d) $2m + 2n$
- 42.** A computer uses ternary system instead of the traditional binary system. An ' n ' bit string in the binary system will occupy
 (a) $3 + n$ ternary digits
 (b) $2n/3$ ternary digits
 (c) $n(\log_2 3)$ ternary digits
 (d) $n(\log_3 2)$ ternary digits
- *43.** The Boolean expression $A'BE + BCDE + BC'D'E + A'B'DE' + B'C'DE'$ can be simplified to $BE + B'DE'$, if the don't care conditions are
 (a) $ABCDE + AB'CDE'$
 (b) $ABCD + AB'CDE' + ABCD'E$
 (c) $ABC'DE + AB'CDE' + ABCD'E$
 (d) none of the above
- 44.** The decimal equivalent of the binary number 101.101 is
 (a) 5.6249
 (b) 5.625
 (c) 5.5
 (d) 5.25
- 45.** Which of the following does not have 8 data lines?
 (a) 8085
 (b) 8086
 (c) 8088
 (d) Z-80
- 46.** Which of the following logic families is well suited for high-speed operation?
 (a) TTL
 (b) ECL
 (c) MOS
 (d) CMOS
- 47.** The following arrangement of JK flip-flops does the function of a

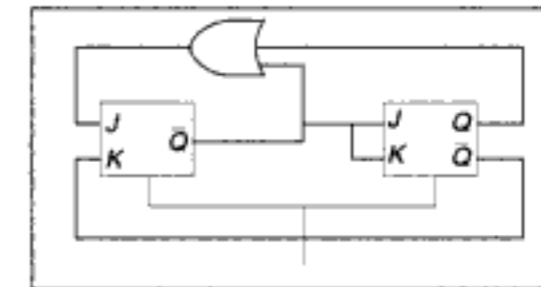

Fig. 8.1

- (a) Shift register
 (b) Mod-3 counter
 (c) Mod-2 counter
 (d) none of the above
- 48.** Negative numbers cannot be represented in
 (a) signed magnitude form
 (b) 1's complement form
 (c) 2's complement form
 (d) none of the above
- 49.** The addressing mode used in an instruction of the form $ADD\ X\ Y$, is
 (a) absolute
 (b) immediate
 (c) indirect
 (d) index
- *50.** The combinational circuit in Fig. 8.2 can be replaced by a single
 (a) OR gate
 (b) XOR gate
 (c) NOR gate
 (d) AND gate
- *51.** $(10110011100011110000)_2$ in base 32 is
 (a) 22 14 7 16
 (b) 11 9 23 31
 (c) 11 9 7 16
 (d) 11 14 23 16

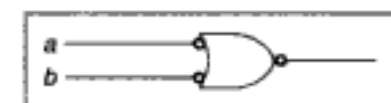

Fig. 8.2

- *29. Which of the following weights makes the complement operation easier in BCD form?
 (a) 8-4-2-1 (b) Excess-3 (c) 2-4-2-1 (d) 3-2-1-0
30. The sequence of events that happen during a typical fetch operation is
 (a) PC → Mar → Memory → MDR → IR (b) PC → Memory → MDR → IR
 (c) PC → Memory → IR (d) PC → MAR → Memory → IR
- *31. Any given Boolean expression can be implemented by using
 (a) only NAND gates (b) only NOR gates
 (c) only OR gates (d) only AND gates
- *32. To get Boolean expression in the product of sum form, from a given Karnaugh map
 (a) don't care conditions should not be present
 (b) don't care conditions, if present, should be taken as zeroes
 (c) one should cover all the 0's present and complement the resulting expression
 (d) one should cover all the 1's present and complement the resulting expression
- *33. The Boolean expression $AB + AB' + A'C + AC$ is unaffected by the value of the Boolean variable
 (a) A (b) B (c) C (d) none of the above
- *34. The minimum number of gates required to implement the Boolean expression $AB + AB' + A'C$ is
 (a) 1 AND gate and 1 OR gate (b) 2 NAND gates
 (c) 3 AND gates and 2 OR gates (d) none of the above
35. Property of locality of reference may fail if a program has
 (a) many conditional jumps (b) many unconditional jumps
 (c) many operands (d) none of the above
36. Which of the following comments about half adder are true?
 (a) It adds 2 bits.
 (b) It is called so because a full adder involves two half-adders.
 (c) It does half the work of a full adder.
 (d) It needs two input and generates two output.
37. The binary equivalent of the decimal number 0.4375 is
 (a) 0.0111 (b) 0.1011 (c) 0.1100 (d) 0.1010
- *38. The Boolean expression $(A + C)(AB' + AC)(A'C' + B')$ can be simplified to
 (a) AB (b) $AB + A'C$ (c) $A'B + BC$ (d) $AB + BC$
- *39. A byte addressable computer has a memory capacity of 2^m kbytes and can perform 2^n operations. An instruction involving 3 operands and one operator needs a maximum of
 (a) $3m$ bits (b) $3m + n$ bits (c) $m + n$ bits (d) none of the above
- *40. In the previous problem, if the computer is word addressable with the word size being 8 bytes then the answer will be
 (a) $3m$ bits (b) $3m + n$ bits (c) $m + n$ bits (d) none of the above

- *120. If the proposition $\neg P \Rightarrow Q$ is true, then the truth value of the proposition $\neg P \vee (P \Rightarrow Q)$, is
 (a) true (b) multi-valued (c) false (d) cannot be determined
- *121. The number of divisors of 600 (including 1 and 600) is
 (a) 24 (b) 22 (c) 23 (d) 25
- *122. The determinant value of the matrix $\begin{pmatrix} 1 & 2 & 3 \\ 4 & 5 & 6 \\ 5 & 7 & 9 \end{pmatrix}$ is
 (a) 12 (b) 16 (c) 42 (d) none of the above
- *123. Which of the following elementary operations may affect the rank of a matrix?
 (a) Scalar multiplication
 (b) Adding two rows
 (c) Adding a row with the scalar multiple of another row
 (d) None of the above
124. Which of the following will not form an abelian group?
 (a) Addition over the set of natural numbers (b) Subtraction over the set of integers
 (c) Multiplication over the set of integers (d) None of the above
- *125. A group has 11 elements. The number of proper sub-groups it can have is
 (a) 0 (b) 11 (c) 5 (d) 4
- *126. Let A and B be two $n \times n$ real symmetric matrices. Then
 (a) $AA^t = I$ (d) $A = A^{-1}$ (c) $AB = BA$ (d) $(AB)^t = BA$.
127. Backward Euler method for solving the differential equation $dy/dx = f(x, y)$, is specified by
 (a) $y_{n+1} = y_n + hf(x_n, y_n)$ (b) $y_{n+1} = y_n + hf(x_{n+1}, y_{n+1})$
 (c) $y_{n+1} = y_{n-1} + 2hf(x_n, y_n)$ (d) $y_{n+1} = (1 + h)f(x_{n+1}, y_{n+1})$
- *128. Let A and B be two arbitrary events. Then
 (a) $P(A \cap B) = P(A)P(B)$ (b) $P(A \cup B) = P(A) + P(B)$
 (c) $P(A/B) = P(A \cap B) + P(B)$ (d) $P(A \cup B) \leq P(A) + P(B)$
129. The rank of the matrix $\begin{pmatrix} 0 & 0 & -3 \\ 9 & 3 & 5 \\ 3 & 1 & 1 \end{pmatrix}$ is
 (a) 0 (b) 1 (c) 2 (d) 3
- *130. $(G, *)$ is an abelian group. Then
 (a) $x = x^{-1}$, for any x belonging to G
 (b) $x = x^2$, for any x belonging to G
 (c) $(x^*y)^2 = x^2*y^2$, for any x, y belonging to G
 (d) G is of finite order

131. In a compact single dimensional array representation for lower triangular matrices (i.e., all the elements above the diagonal are zero), of size $n \times n$, non-zero elements (i.e., elements of the lower triangle) of each row are stored one after the other, starting from the first row. The index of the (i, j) th element of the lower triangular matrix in this new representation is
 (a) $i + j$ (b) $i + j - 1$ (c) $j + i(i-1) / 2$ (d) $i+j(j-1) / 2$
- *132. The number of sub-strings (of all lengths) that can be formed from a character string of length n is
 (a) n (b) n^2 (c) $n(n-1) / 2$ (d) $n(n+1) / 2$
133. In the set of natural numbers, the binary operators that are not associative and not commutative are
 (a) addition (b) subtraction (c) multiplication (d) division
- *134. A relation R is defined as xRy , if $x \neq y$. This relation R is
 (a) symmetric but not reflexive
 (b) symmetric and transitive, but not reflexive
 (c) not reflexive, not symmetric, and not transitive
 (d) an equivalence relation
135. The number of subsets of $\{1, 2, \dots, n\}$ of odd cardinality is
 (a) dependent on the value of n (b) 2^{n-1} , if n is odd
 (c) 2^{n-1} , if n is even (d) 2^{n-1} , for any value of n
- *136. The probability of an event B occurring is P . The probability that events A and B occur together is Q . The probability that A occurs, without B occurring, is R . Then the probability of A occurring is
 (a) $P + Q + R$ (b) $P + Q - R$ (c) $Q + R$ (d) $P - Q - R$
137. Let A, B, C be independent events with probabilities 0.8, 0.5, 0.3. The probability of occurrence of at least one of these three is
 (a) 0.3 (b) 0.93 (c) 0.12 (d) 0.07
138. The subset of a countable set
 (a) has to be countable (b) may or may not be countable
 (c) has to be finite (d) none of the above
139. Every element of some ring $(R, +, *)$ is such that $a * a = a$. This ring
 (a) is commutative (b) is non-commutative
 (c) may or may not be commutative (d) none of the above
140. For the M/G/1 queuing system, the arrival pattern and service time follows
 (a) Poisson and Binomial (b) Binomial and Poisson
 (c) General and Poisson (d) Poisson and General
141. Consider the set $\{1, 2, 3, 4, 6, 8, 12, 24\}$, together with the two binary operations LCM (Least Common Multiple) and GCD (Greatest Common Divisor). Which of the following does this algebraic structure represent?
 (a) Group (b) Ring (c) Field (d) Lattice

19. Which of the following remarks about BCD are true?
 (a) It is a 8-4-2-1 weighted code
 (b) Complement of a number can be found efficiently
 (c) $(12345678)_{10}$ needs 4 bytes in BCD representation
 (d) Conversion to and from the decimal system can be done easily
20. The first operating system used in microprocessors is
 (a) Zenix (b) DOS (c) CP/M (d) Multics
21. Which of the following remarks about PLA is/are true?
 (a) It produces product of sum as the output.
 (b) It produces sum of products as the output.
 (c) It is dedicated for a particular operation.
 (d) It is general.
- *22. Any given truth table can be represented by a
 (a) Karnaugh map
 (b) sum of product of Boolean expressions
 (c) product of sum of Boolean expressions
 (d) none of the above
- *23. A number system uses 20 as the radix. The excess code that is necessary for its equivalent binary coded representation is
 (a) 4 (b) 5 (c) 6 (d) 7
24. Choose the correct statements.
 (a) Bus is a group of information carrying wires.
 (b) Bus is needed to achieve reasonable speed of operation.
 (c) Bus can carry data or address.
 (d) A bus can be shared by more than one device.
- *25. $A+B$ can be implemented by
 (a) NAND gates alone (b) NOR gates alone
 (c) AND gates alone (d) none of the above
26. Bipolar devices are desirable in the fabrication of which of the following components?
 (a) Main memory (b) Cache memory
 (c) Micro program memory (d) All of the above
27. Which of the following is the programmable internal timer?
 (a) 8251 (b) 8250 (c) 8253 (d) 8275
- *28. The idea of cache memory is based on the
 (a) property of locality of reference
 (b) fact that only a small portion of a program is referenced relatively frequently
 (c) heuristic 90-10 rule
 (d) fact that references generally tend to cluster

- *8. If X, Y and Z are 3 Boolean variables, then $X(Y + Z)$ equals $(X + Y)(X + Z)$, if X, Y, Z take the values
 (a) 1, 0, 0 (b) 0, 1, 0 (c) 1, 1, 0 (d) 0, 1, 1
- *9. Which of the following comments about the Program Counter (PC) are true?
 (a) It is a register.
 (b) It is a cell in ROM.
 (c) During execution of the current instruction, its content changes.
 (d) None of the above.
- *10. If $(123)_5 = (A3)_B$, then the number of possible values of A is
 (a) 4 (b) 1 (c) 3 (d) 2
11. The speed imbalance between memory access and CPU operation can be reduced by
 (a) cache memory (b) memory interleaving
 (c) reducing the size of memory (d) none of the above
- *12. If $(12A)_3 = (123)_A$, then the value of A is
 (a) 3 (b) 3 or 4 (c) 2 (d) none of the above
- *13. Choose the correct statements.
 (a) By scanning a bit pattern, one can say whether, it represents data or not.
 (b) Whether a given piece of information is a data or not depends on the particular application.
 (c) Positive numbers can't be represented in 2's complement form.
 (d) Positive numbers can't be represented in 1's complement form.
14. Which of the following does not need extra hardware for DRAM refreshing?
 (a) 8085 (b) Motorola-6800 (c) Z-80 (d) None of the above
15. The advantage of MOS devices over bipolar devices is
 (a) it allows higher bit densities and also cost effective
 (b) it is easy to fabricate
 (c) its higher-impedance
 (d) its operational speed
- *16. The Boolean expression $X + X'Y$ equals
 (a) $X + Y$ (b) $X + XY$ (c) $Y + YX$ (d) $X'Y + Y'X$
- *17. $(X + Y) + Z = X + (Y + Z)$
 (a) shows that the Boolean operator OR is distributive
 (b) shows that the Boolean operator OR is associative
 (c) implies the associativity of the Boolean operator AND
 (d) none of the above
18. Which of the following are registers?
 (a) Accumulator (b) Stack pointer (c) Program counter (d) Buffer

- *142. The set $\{1, 2, 3, 4, 6, 8, 12, 24\}$, together with LCM as the binary operation is not a group, because
 (a) it is not closed (b) it is not associative
 (c) identity does not exist (d) inverse does not exist
- *143. The set $\{1, 2, 3, 4, 6, 8, 12, 24\}$, together with GCD as the binary operation is not a group, because
 (a) it is not associative (b) identity does not exist
 (c) inverse is not unique (d) inverse does not exist
144. The following set
 (a) $Q(x) \rightarrow P(x) \vee \neg R(a)$ (b) $R(a) \vee \neg Q(a)$
 (c) $Q(a)$ (d) $\neg P(y)$
 where x and y are universally quantified variables, a is a constant and P, Q, R are monadic predicates, is
 (a) consistent (b) inconsistent
 (c) may be consistent (d) none of the above
- *145. Let X and Y be sets with cardinalities m and n respectively. If the number of possible functions that can be defined with domain X and co-domain Y is exactly 10, then
 (a) $m = n = 10$ (b) $m = 1; n = 10$ (c) $m = 10; n = 1$ (d) $m = 5; n = 5$
146. Let $F: R^2 \rightarrow R^2$ be the mapping defined by $F(x, y) = (x/3, y/4)$. What will be the image of $x^2/9 + y^2/16 = 1$ under F ?
 (a) The circle $x^2 + y^2 = 1$ (b) The line $x/3 + y/4 = 1$
 (c) The ellipse $x^2 + y^2 = 1$ (d) None of the above
- *147. A function g is defined as $g(x) = f(x)[f(x) + f(-x)]$. Which of the following remarks about the function g is right?
 (a) g is even for all f (b) g is odd for all f
 (c) g is even if f is even (d) g is even if f is odd
148. If $x \in [0, 1]$, and $f(x)$ and $g(x)$ are defined as $f(x) = \sin(\cos(x\pi/4))$ and $g(x) = \cos(\sin(x\pi/4))$, then
 (a) f is monotonic increasing and g is monotonic decreasing
 (b) f is monotonic increasing and g is monotonic increasing
 (c) f is monotonic decreasing and g is monotonic decreasing
 (d) f is monotonic decreasing and g is monotonic increasing
149. What is the total number of equivalent relations that can be defined on the set $\{1, 2, 3\}$?
 (a) 8 (b) 64 (c) 5 (d) 3
- *150. Cube roots of unity form a cyclic group under multiplication. For this group,
 (a) ω is the only generator (b) ω, ω^2 are the only generators
 (c) ω^2 is the only generator (d) none of the above
- *151. The value of $\lim_{x \rightarrow 0} x \log x$ is
 (a) $-\infty$ (b) ∞ (c) 1 (d) 0

152. The function $f(x)$ is continuous in $[0, 1]$, such that $f(0) = -1$, $f(1/2) = 1$ and $f(1) = -1$. We can conclude that
- f attains the value zero at least twice in $[0, 1]$
 - f attains the value zero exactly once in $[0, 1]$
 - f is non-zero in $[0, 1]$
 - f attains the value zero exactly twice in $[0, 1]$
153. The sum of the infinite series $\sum kx^k$, where $-1 < x < 1$, is
- $x/(1-x)$
 - $x/(1-x)^2$
 - $x^2/(1-x)^2$
 - $1/(1-x)$
154. Which of the following is not a linear transformation?
- $f: R^3 \rightarrow R^2$ defined by $f(x, y, z) = (x, z)$
 - $f: R^3 \rightarrow R^3$ defined by $f(x, y, z) = (x, y - 1, z)$
 - $f: R^2 \rightarrow R^2$ defined by $f(x, y) = (2x, y - x)$
 - $f: R^2 \rightarrow R^2$ defined by $f(x, y) = (y, x)$
155. If the determinant of an $n \times n$ matrix A is zero, then
- rank of A is n
 - rank of $A \leq n - 2$
 - A has at least one zero eigen value
 - the system of equations $Ax = 0$ has no solution other than the trivial solution
156. A is a 2×2 matrix with eigen values 2 and -3 . The eigen values of the matrix A^2
- are 4 and -9
 - are 2 and -3
 - are 4 and 9
 - cannot be determined from the given data
157. Among any $n + 1$ distinct positive integers less than or equal to $2n$, we can always find
- n numbers that are relatively prime to $2n$
 - two numbers that are relatively prime to each other
 - two prime numbers
 - none of the above
158. Let X_1 and X_2 be any two unit vectors in R^3 . The angle between the two planes $X_1 \cdot X = c$ and $X_2 \cdot X = 2c$, where c is a constant is given by
- 0
 - $(X_1 \cdot X_2)/2$
 - $X_1 \cdot X_2$
 - none of the above
159. If $(x_1, x_2, x_3) \times (1, 3, 1) = (2, 1, 6)$, where \times denotes the vector product, then (x_1, x_2, x_3) is given by
- $(0, 1, 1)$
 - $(m, 0, 1 - m)$ for all real m
 - $(-1, 2, -7)$
 - there does not exist any such (x_1, x_2, x_3) in R^3
160. Which of the following is a cube root of the complex number $-27i$?
- $-3i$
 - $-3/2(\sqrt{3} + i)$
 - $-3/2(\sqrt{3} - i)$
 - $3(\sqrt{3} - 1)$
161. Suppose a system has been evolved by extraterrestrial creatures having only 3 fingers. They use the figures 0, 1, 2 with $2 > 1 > 0$. What will be the binary equivalent of 222 in this system?
- 101010
 - 11000
 - 10110
 - 11010

Explanations

25. Consider the string $a+a^*a$. It can be derived as
- $$E \rightarrow E+E \rightarrow E+E^*E \rightarrow a+E^*E \rightarrow a+a^*E \rightarrow a+a^*a$$
- or
- $$E \rightarrow E^*E \rightarrow E+E^*E \rightarrow a+E^*E \rightarrow a+a^*E \rightarrow a+a^*a$$
- Since we know a string that can be derived in more than one way, the given grammar is ambiguous.
27. abc can be derived as follows.
- $$S \rightarrow Abc \rightarrow abc \text{ using } (Ab \rightarrow ab)$$
- As we see, any production from the start state has to end in c . So aab is impossible. Options (c) and (d) are also not possible.
28. Generate some of the strings that can be derived from the start state and verify that they fall into the category covered by option (d).
47. If memory space is not the constraint, then by increasing the number of bins to K , the access time can be reduced by a factor of K . So, average number of items in a bin will decrease as the number of bins increases. In the case of list, access time will be proportional to n , the number of items, but we will be using as much memory space as is absolutely necessary. In the case of search tree implementation, the access time will be logarithmic.
69. Any shift-reduce parser typically works by shifting entries onto the stack. If a handle is found on the top of the stack, it is popped and replaced by the corresponding left hand side of the production. If ultimately we have only the starting non-terminal on the stack, when there are no more tokens to be scanned, the parsing will be successful. So, it is bottom-up.
94. The right-most derivation of the string $xxxxyzzz$ is,
- $$S \rightarrow xxW \rightarrow xxSz \rightarrow xxxWz \rightarrow xxxSzz \rightarrow xxxxyz.$$
- A shift reduce parser, performs the right-most derivation in reverse. So, first it reduces the y to s , by the production $S \rightarrow y$. As a consequence of this, 2 is immediately printed. Next, Sz is reduced to W , by the production $W \rightarrow Sz$. So, 3 will be printed. Proceeding this way, we get the output string 23131.
95. It is because, it is equivalent to recognizing wcw , where the first w is the declaration and the second is its use. wcw is not a CFG.

$FOLLOW_k(A)$ is the set of all derivable terminal strings of length k or less, that can follow A in some left-most sentential form.

The next three questions are based on the above definition.

88. Consider the grammar

$$\begin{aligned} E &\rightarrow TE' \\ E' &\rightarrow +TE' \mid \epsilon \\ T &\rightarrow FT' \\ T' &\rightarrow *FT' \mid \epsilon \\ F &\rightarrow (E) \mid id \end{aligned}$$

$FIRST_1(E)$ will be same as that of

(a) $FIRST_1(T)$ (b) $FIRST_1(F)$ (c) $FIRST_1(T')$ (d) all of the above

89. $FOLLOW_1(F)$ is

(a) $\{+, *,), \$\}$ (b) $\{+,), \$\}$
(c) $\{*,), \$\}$ (d) $\{+, (,), *\}$

90. Which of the following remarks logically follows?

(a) $FIRST_k(\epsilon) = \{\epsilon\}$
(b) If $FOLLOW_k(A)$ contains ϵ , then A is the start symbol
(c) If $A \rightarrow w$, is a production in the given grammar G , then $FIRST_k(A)$ contains $FIRST_k(w)$
(d) If $A \rightarrow w$, is a production in the given grammar G , then $FIRST_k(w)$ contains $FIRST_k(A)$

91. Merging states with a common core may produce _____ conflicts but does not produce _____ conflicts in an LALR parser

(a) reduce-reduce; shift-reduce (b) shift-reduce; reduce-reduce
(c) shift-reduce; shift-reduce (d) none of the above

92. For a CFG, $FOLLOW(A)$ is the set of all terminals that can immediately appear to the right of the non-terminal A in some sentential form. We define two sets $LFOLLOW(A)$ and $RFOLLOW(A)$ by replacing the word sentential by "Left most sentential" and "Right most sentential" respectively in the definition of $FOLLOW(A)$.

Choose the correct statement(s).

(a) $FOLLOW(A)$ and $LFOLLOW(A)$ may be different
(b) $FOLLOW(A)$ and $RFOLLOW(A)$ are always the same
(c) All the three are same
(d) All the three are different

93. In a programming language, an identifier is permitted to be a letter followed by any number of letters or digits. If L and D denote the set of letters and digits respectively, which of the following expressions defines an identifier?

(a) $(L \cup D)^+$ (b) $L.(L \cup D)^*$ (c) $(L.D)^*$ (d) $L.(L.D)^*$

162. If you want to retain the first 4 bits of given string of 8 bits and complement the last 4 bits then the correct mask and the operation should be

(a) XOR and 00001111 (b) XOR and 11110000
(c) AND and 00001111 (d) OR and 11110000

163. Which of the following logical operation almost resembles an arithmetic multiplication operation?

(a) OR (b) AND (c) NOR (d) XOR

164. To change lower case to upper case letters in ASCII, the correct mask and operation should be (ASCII value of character A is 65 and character a is 97)

(a) 0100000 and NOR (b) 0100000 and OR
(c) 0100000 and NAND (d) 1011111 and AND

*165. Consider the nested for loop

```
for I1 = 1 to N
  for I2 = 1 to I1
    for I3 = 1 to I2
```

```
      for Ik = 1 to I(k-1)
        PRINT I1, I2, I3, ..., Ik
```

How many times is the PRINT statement executed?

(a) k^N (b) ${}^{(k+N-1)}C_k$ (c) ${}^{(k-N+1)}C_k$ (d) ${}^{(k-N-1)}C_k$

The next three questions are based on the following assumptions.

Let $f(x)$ represent the largest integer less than or equal to x . Let $g(x)$ represent the smallest integer greater than or equal to x .

166. Which of the following remark(s) will be true for any x ?

(a) $g(x) = f(x) + 1$ (b) $f(x) = g(x)$
(c) $f(-x) = -g(x)$ (d) all of the above

167. Which of the following, lists $f(x)$, $g(x)$, x , $x-1$ and $x+1$ in a non-decreasing sequence?

(a) $x-1, x, g(x), f(x), x+1$ (b) $x-1, x, f(x), g(x), x+1$
(c) $x-1, f(x), x, g(x), x+1$ (d) $x-1, x, g(x), x+1, f(x)$

168. $x \bmod y$ is

(a) $x - yf(x)$ (b) $x - xf(y)$ (c) $x - yf(x/y)$ (d) $x - xf(x/y)$

169. For $n > 2$, the equation $x^n + y^n = z^n$, has no solution in positive integers. This is

(a) Fermat's last theorem (b) Ramanujan Ecumenical theorem
(c) Newton's last theorem (d) Fermat's last theorem

*170. Which of the following values of x , y , and z , satisfies the equation $x^2 + y^2 = z^2$?

(a) $x = 121, y = 407, z = 887$ (b) $x = 777, y = 333, z = 101$
(c) $x = 7, y = 47, z = 57$ (d) None of the above

- *171. Which of the following values of x , y , and z , satisfies the equation $x^2 + y^2 = z^2$?
- (a) $x=122, y=406, z=887$ (b) $x=778, y=334, z=101$
 (c) $x=8, y=47, z=58$ (d) None of the above
- *172. According to the principle of logic, an implication and its contrapositive must be
- (a) both true or both false (b) both true
 (c) both false (d) none of the above
173. If an implication and its converse are both true, then they can be combined using
- (a) if and only if (b) as long as (c) if...then...else (d) such that
- *174. Associate a code with each letter of the alphabet such that the code of an alphabet is its position in the alphabet set. For example, code of c is 3, y is 25 etc., What can you say about the word that is made up of alphabets whose product of the codes is 637245?
- (a) It must have at least two B's (b) It must have at least two Y's
 (c) It must have at least two Z's (d) It must have at least two Q's
- *175. Associate a code with each letter of the alphabet such that the code of a letter is its position in the alphabet set. For example, code of c is 3, y is 25 etc., Find the word that is made up of the letters whose product of the codes is 124950.
- (a) Impossible to find (b) No such word exists
 (c) The word is DELHI (d) None of the above
- *176. Associate a code with each letter of the alphabet such that the code of a letter is its position in the alphabet set. For example, code of c is 3, y is 25 etc., Find the word that is made up of the letters whose product of the codes is 3135.
- (a) The word is CHESS (b) No such word exists
 (c) More than one such word exist (d) None of the above
- *177. Associate a code with each letter of the alphabet such that the code of a letter is its position in the alphabet set. For example, code of c is 3, y is 25, etc. Find the word that is made up of the letters whose product of the codes is 1265.
- (a) The word is WASP (b) No such word exists
 (c) More than one such word exist (d) None of the above
- *178. What is the largest 10-digit integer, containing all the numerals 1,2,3,4,5,6,7,8,9,0, that is divisible by 4?
- (a) 9876543210 (b) 987654204
 (c) 9876543120 (d) None of the above
- *179. What is the largest 10-digit integer, containing all the numerals 1,2,3,4,5,6,7,8,9,0, that is divisible by 8?
- (a) 9876543210 (b) 987654204
 (c) 9876543120 (d) None of the above
- *180. What is the smallest 10-digit positive integer, containing all the numerals 1,2,3,4,5,6,7,8,9,0, that is divisible by 8?
- (a) 1023456789 (b) 01234567968
 (c) 1023457986 (d) None of the above

80. Consider an ϵ -free CFG. If for every pair of productions $A \rightarrow u$ and $A \rightarrow v$
- (a) if $FIRST(u) \cap FIRST(v)$ is empty then the CFG has to be LL(1)
 (b) if the CFG is LL(1) then $FIRST(u) \cap FIRST(v)$ has to be empty
 (c) if $FIRST(u) \cap FIRST(v)$ is empty then the CFG cannot be LL(1)
 (d) none of the above
81. LR(k) grammar
- (a) can only examine a maximum of k input symbols
 (b) can be used to identify handles
 (c) can be used to identify the production associated with a handle
 (d) covers the LL(k) class
82. The set of all viable prefixes of right sentential form of a given grammar
- (a) can be recognized by a finite state machine
 (b) cannot be recognized by a finite state machine
 (c) can be used to control an LR(k) parser
 (d) none of the above
83. The 'k', in LR (k) cannot be
- (a) 0 (b) 1 (c) 2 (d) none of the above

The next three questions are based on the following grammar

$$\begin{aligned} E &\rightarrow E/X \mid X \\ X &\rightarrow T-X \mid X*T \mid T \\ T &\rightarrow T+F \mid F \\ F &\rightarrow (E) \mid id \end{aligned}$$

(id stands for identifier)

84. This grammar is
- (a) unambiguous (b) ambiguous (c) context-free (d) none of these
85. The above grammar is used to generate all valid arithmetic expressions in a hypothetical language in which
- (a) / associates from the left (b) - associates from the left
 (c) + associative from the left (d) * associative from the left
86. The above grammar is used to generate all valid arithmetic expressions in a hypothetical language in which
- (a) + has the highest precedence (b) * has the highest precedence
 (c) - has the highest precedence (d) / has the highest precedence
87. Back-patching is useful for handling
- (a) conditional jumps (b) unconditional jumps
 (c) backward references (d) forward references

Let x be a string and let A be a non-terminal. $FIRST_k(x)$ is the set of all leading terminal strings of length k or less, in the strings derivable from x .

61. Reduction in strength means
- replacing run time computation by compile time computation
 - removing loop invariant computation
 - removing common sub-expressions
 - replacing a costly operation by a relatively cheaper one
62. A basic block can be analyzed by a
- DAG
 - graph which may involve cycles
 - flow-graph
 - none of the above
63. *ud*-chaining is useful for
- determining whether a particular definition is used anywhere or not
 - constant folding
 - checking whether a variable is used, without prior assignment
 - none of the above
64. Which of the following concepts can be used to identify loops?
- Dominators
 - Reducible graphs
 - Depth first ordering
 - None of the above
65. Which of the following are not loop optimization techniques?
- Jamming
 - Unrolling
 - Induction variable elimination
 - None of the above
66. Running time of a program depends on the
- way the registers are used
 - order in which computations are performed
 - way the addressing modes are used
 - usage of machine idioms
67. *du*-chaining
- stands for use definition chaining
 - is useful for copy propagation removal
 - is useful for induction variable removal
 - none of the above
68. Which of the following comments about peep-hole optimization are true?
- It is applied to a small part of the code.
 - It can be used to optimize intermediate code.
 - To get the best out of this technique, it has to be applied repeatedly.
 - It can be applied to a portion of the code that is not contiguous.
- *69. Shift-reduce parsers are
- top-down parsers
 - bottom-up parsers
 - may be top-down or bottom-up parsers
 - none of the above

- *181. What is the largest 10-digit integer, containing all the numerals 1,2,3,4,5,6,7,8,9,0, that is divisible by 11?
- 9876543210
 - 987654204
 - 9876524130
 - 9876543120
182. Manoj had 4 pairs of identical black socks and 5 pairs of identical green socks in a box. With his eyes closed, he took them out one by one. How many socks should he take out before he has a matching pair? (Assume that what is taken out is not put back.)
- 3
 - 5
 - 6
 - 10
183. Ramu had 2 pairs of identical yellow socks, 3 pairs of identical blue socks, 4 pairs of identical green socks, and 5 pairs of identical red socks in a box. With his eyes closed, he took them out one by one. How many socks should he take out before he is guaranteed to have a pair of red socks? (Assume that what is taken out is not put back.)
- 5
 - 6
 - 15
 - 20
184. Manoj had 4 pairs of black shoes and 5 pairs of green shoes in a box. With his eyes closed, he took them out one by one. How many shoes should he take out before he has a matching pair? (Assume that what is taken out is not put back.)
- 5
 - 6
 - 10
 - 14
- *185. Gopal was given an apple and a knife. He was asked to make it into a cube. What is the minimum number of cuts that he needs to make?
- 4
 - 6
 - 8
 - 12
- *186. Sankar asked Saleem to cut his chappathi into as many pieces as possible in 3 cuts. No piece can be moved until the third cut. Saleem did it right. How many pieces did he make?
- 5
 - 6
 - 7
 - 8
- *187. Akbar asked Amar to cut his chappathi into as many pieces as possible in 4 cuts. No piece can be moved until the third cut. Amar did it right. How many pieces did he make?
- 8
 - 9
 - 10
 - 11
- *188. A can is filled with 5 paise coins. Another can is filled with 10 paise coins. Another can is filled with 25 paise coins. All the cans are given wrong labels. If the can labeled 25 paise is not having the 10 paise coins, what will the can, labeled 10 paise have?
- 25 paise
 - 5 paise
 - 10 paise
 - Cannot be determined
- *189. A can is filled with 5 paise coins. Another can is filled with 10 paise coins. Another can is filled with 5 and 10 paise coins. All the cans are given wrong labels. You need to identify the can that has the 10 paise coins in it. You are allowed to inspect only one coin from a can, of your choice. Which can must you choose?
- The can that is filled with 5 paise coins.
 - The can that is filled with 10 paise coins.
 - The can that is filled with 5 and 10 paise coins.
 - Cannot be determined
- *190. Sami wrote 5 different letters. He prepared 5 different envelopes for the 5 letters. If he randomly distributed the 5 letters to the 5 envelopes, what is the probability that each letter gets into the correct envelope?
- 1/2
 - 1/5
 - 1/60
 - 1/120

191. Priya takes 6 minutes to walk to her school from her house. Bianca who lives in the same house can walk to the same school 8 times in an hour. Who walks faster?
 (a) Priya (b) Bianca
 (c) Cannot be determined from the facts given (d) None of these
192. Vinod took a certain number of tests. Out of 10, his scores on the first 9 tests were 1, 2, 3, 4, 5, 6, 7, 8, and 9. In all the other tests, he scored 10 out of 10. If his average score is 9, how many tests did he take?
 (a) 40 (b) 50 (c) 60 (d) None of these
193. AB and XY are 2 two-digit numbers. A, B, X, and Y are assigned values from 5, 6, 8, and 9. How should the assignment be done so that $AB - XY$ is minimum?
 (a) A=9, B=5, X=8, and Y=6 (b) A=9, B=8, X=5, and Y=6
 (c) A=9, B=5, X=6, and Y=8 (d) None of these
194. 10 machines can cut 100 papers in 10 minutes. How many minutes does it take 20 machines to cut 200 papers?
 (a) 10 (b) 20 (c) 30 (d) 40
195. 10 machines can cut 100 papers in 10 minutes. How many papers will be cut by 5 machines in 1 hour?
 (a) 200 (b) 300 (c) 400 (d) 500
196. Siva, Varma, and Patil ran a 100 meter race. Siva finished first beating Varma by 20 meters, and Patil by 30 meters. If Varma and Patil run a 100 meter race, with Varma giving Patil a head start of 10 meters, who will win the race?
 (a) Siva (b) Varma
 (c) Patil (d) Cannot be determined from the given facts.
197. A six-digit number 123ABC is exactly divisible by 5, 7, and 9. How many such possible numbers are there?
 (a) 2 (b) 3 (c) 4 (d) 5
198. A train traveling at 60 km/h takes 3 seconds to enter a tunnel. The same train takes 30 seconds to completely come out of the tunnel. What is the length of the tunnel in meters?
 (a) 400 (b) 500 (c) 600 (d) None of these
199. Here are the statements of 4 boys.
 Mani : Subbu ate it
 Subbu : Joshi ate it
 Kumar : I didn't eat it
 Joshi : I didn't eat it
 Only one of them is telling the truth. Who ate it?
 (a) Mani (b) Subbu (c) Kumar (d) Joshi
200. AB and BA are 2 two-digit numbers such that $AB + BA = CAC$. What is $A+B+C$? (Assume C is not 0)
 (a) 13 (b) 14 (c) 15 (d) None of these

49. Access time of the symbol table will be logarithmic, if it is implemented by a
 (a) linear list (b) search tree (c) hash table (d) self-organizing list
50. An ideal compiler should
 (a) detect error (b) detect and report error
 (c) detect, report and correct error (d) none of the above
51. Which of the following is not a source of error?
 (a) Faulty design specification (b) Faulty algorithm
 (c) Compiler themselves (d) None of the above
52. Any transcription error can be repaired by
 (a) insertion alone (b) deletion alone
 (c) insertion and deletion alone (d) replacement alone
53. Hamming distance is a
 (a) theoretical way of measuring errors
 (b) technique for assigning codes to a set of items known to occur with a given probability
 (c) technique for optimizing the intermediate code
 (d) none of the above
54. Error repair may
 (a) increase the number of errors (b) generate spurious error messages
 (c) mask subsequent errors (d) none of the above
55. A parser with the valid prefix property is advantageous because
 (a) it detects error as soon as possible
 (b) it detects errors as and when they occur
 (c) it limits the amount of erroneous output passed to the next phase
 (d) all of the above
56. The advantage of panic mode of error recovery is that
 (a) it is simple to implement (b) it is very effective
 (c) it never gets into an infinite loop (d) none of the above
57. To recover from an error, the operator precedence parser may
 (a) insert symbols onto the stack (b) insert symbols onto the input
 (c) delete symbols from the stack (d) delete symbols from the input
58. Which of the following optimization techniques are typically applied on loops?
 (a) Removal of invariant computation (b) Elimination of induction variables
 (c) Peephole optimization (d) Constant folding
59. The technique of replacing run time computations by compile time computations is called
 (a) constant folding (b) code hoisting
 (c) peephole optimization (d) invariant computation
60. The graph that shows the basic blocks and their successor relationship is called
 (a) control graph (b) flow graph (c) DAG (d) Hamiltonian graph

38. Choose the correct statements.
- Topological sort can be used to obtain an evaluation order of a dependency graph.
 - Evaluation order for a dependency graph dictates the order in which the semantic rules are done.
 - Code generation depends on the order in which the semantic actions are performed.
 - Only (a) and (c) are correct.
39. A syntax tree
- is another name for a parse tree
 - is a condensed form of parse tree
 - should not have keywords as leaves
 - none of the above
40. Syntax directed translation scheme is desirable because
- it is based on the syntax
 - its description is independent of any implementation
 - it is easy to modify
 - only (a) and (c) are correct
41. Which of the following is not an intermediate code form?
- Postfix notation
 - Syntax trees
 - Three address codes
 - Quadruples
42. Three address codes can be implemented by
- indirect triples
 - direct triples
 - quadruples
 - none of the above
43. Three address code involves
- exactly 3 addresses
 - at the most 3 addresses
 - no unary operator
 - none of the above
44. Symbol table can be used for
- checking type compatibility
 - suppressing duplicate error messages
 - storage allocation
 - none of the above
45. The best way to compare the different implementations of symbol table is to compare the time required to
- add a new name
 - make an inquiry
 - add a new name and make an inquiry
 - none of the above
46. Which of the following symbol table implementation is based on the property of locality of reference?
- Linear list
 - Search tree
 - Hash table
 - Self-organization list
- *47. Which of the following symbol table implementation is best suited if access time is to be minimum?
- Linear list
 - Search tree
 - Hash table
 - Self organization list
48. Which of the following symbol table implementation, makes efficient use of memory?
- List
 - Search tree
 - Hash table
 - Self-organizing list

- *201. You are given a 3 liter can, a 5 liter can, and a bucket of water. You need to use only these two cans to get exactly 4 liters of water in the 5 liter can. Is it possible?
- Yes
 - No
 - No. But, possible if the 4 liters is to be in the bucket.
 - None of these
- *202. A railway track passes through a tunnel. Raman and Gopal are inside the tunnel at a distance of two-fifth from one end, when they heard the sound of a train approaching the tunnel, Raman ran towards one end of the tunnel and Gopal ran towards the other immediately. They both ran at a speed of 15 mi/hr. But, both of them just managed to escape. The speed of the train in miles per hour is,
- 75
 - 83
 - 84
 - cannot be determined from the given facts.
- *203. There are 3 bulbs inside a room. There are 3 switches outside the room. You can enter the room only once. Is it possible to find which switch controls which bulb?
- Yes
 - No
 - No, but possible if allowed to go into the room more than once
 - None of these
- *204. Two people at the two ends of a road tunnel of length 150 km start at two bikes facing each other at 25 km/hr and 50 km/hr respectively. At the same moment, a bird starts flying from one end at 100 km/hr towards the other end until it meets the other person. Once it meets, it reverses direction, and starts flying towards the other person. The bird continues this pattern until the bikes collide head-on. What is the total distance traveled by the bird in kilometers?
- 100
 - 200
 - 300
 - 400
- *205. What is the minimum number of standard weights that can measure any of 1, 2, 3, 4, 5, 6, 7, 8 kg?
- 2
 - 3
 - 4
 - 5
- *206. There are two squares of sides 10 m and 30 m respectively. The smaller square is placed inside the larger one such that the centers coincide and the sides are parallel. The area outside the inner square, but inside the outer square is filled with water. What is the minimum number of square-shaped metal sheets that are needed to reach the inner square from the outer square? Assume the metal sheets can be welded together and the side of the metal sheet measures 1m.
- 7
 - 8
 - 9
 - 10
207. How many squares do you see in this picture?
- 12
 - 13
 - 1
 - 20

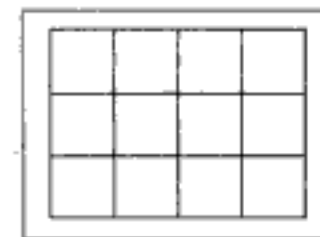

Fig. 4.2

- *208. A rice seller has a balance to measure any quantity of rice that could weigh between 1-40 kg as a whole number. The minimum number of standard weights needed is
- 4
 - 5
 - 6
 - 7

9. The probability that it will rain today is 0.5. The probability that it will rain tomorrow is 0.6. The probability that it will rain either today or tomorrow is 0.7. What is the probability that it will rain today and tomorrow?

- (a) 0.3 (b) 0.25 (c) 0.35 (d) 0.4

10. The determinant of the following matrix is

$$\begin{pmatrix} 6 & -8 & 1 & 1 \\ 0 & 2 & 4 & 6 \\ 0 & 0 & 4 & 8 \\ 0 & 0 & 0 & -1 \end{pmatrix}$$

- (a) 11 (b) -48 (c) 0 (d) -24

11. Let $A = (a_{ij})$ be a n -rowed square matrix and I_{12} be the matrix obtained by interchanging the first and the second rows of the n -rowed identity matrix. Then AI_{12} is such that its first

- (a) row is same as the second row.
 (b) row is same as the second row of A .
 (c) column is the same as the second column of A .
 (d) row is all zero.

12. What is the maximum value of the function $f(x) = 2x^2 - 2x + 6$ in the interval $[0, 2]$?

- (a) 6 (b) 10 (c) 12 (d) 5.5

13. Given $(\sqrt{224})_r = 13)_r$ the value of radix r is

- (a) 10 (b) 8 (c) 5 (d) 6

14. The number of equivalence relations of the set $\{1,2,3,4\}$ is

- (a) 15 (b) 16 (c) 24 (d) 4

15. Which of the following propositions is a tautology?

- (a) $(p \vee q) \rightarrow p$ (b) $p \vee (q \rightarrow p)$ (c) $p \vee (p \rightarrow q)$ (d) $p \rightarrow (p \rightarrow q)$

16. Let R be a reflexive and transitive relation defined on a set D . A new relation E is defined on set D such that

$$E = \{ (a,b) \mid (a,b) \in R \text{ and } (b,a) \in R \}$$

The relation E is

- (a) a partial order (b) a total order
 (c) an equivalence relation (d) none of the above

17. Let R be a reflexive and transitive relation defined on a set D . A new relation E is defined on set D such that

$$E = \{ (a,b) \mid (a,b) \in R \text{ and } (b,a) \in R \}$$

A relation \leq is defined on the equivalent classes of E such that $E_1 \leq E_2$ if there exists a, b such that $a \in E_1, b \in E_2$ and $(a,b) \in R$. This relation is,

- (a) a partial order (b) a total order
 (c) an equivalence relation (d) none of the above

18. A, B are two 8-bit numbers such that $A+B \leq 2^8$. The number of possible combinations of A and B is

- (a) 2^9 (b) 2^8 (c) 2^{16} (d) $2^4 - 1$

- (c) some states have no transition on some tokens
 (d) start state may not be there

30. The main difference between a DFSA and an NDFSA is

- (a) in DFSA, ϵ transition may be present
 (b) in NDFSA, ϵ transitions may be present
 (c) in DFSA, from any given state, there can't be any alphabet leading to two different states.
 (d) in NDFSA, from any given state, there can't be any alphabet leading to two different states.

31. Two finite state machines are said to be equivalent if they

- (a) have the same number of states
 (b) have the same number of edges
 (c) have the same number of states and edges
 (d) recognize the same set of tokens

32. Choose the correct answer.

FORTRAN is a

- (a) regular language (b) context-free language
 (c) context-sensitive language (d) Turing language

33. If two finite states machine M and N are isomorphic, then M can be transformed to N by re-labeling

- (a) the states alone (b) the edges alone
 (c) both the states and edges (d) none of the above

34. In a syntax directed translation scheme, if the value of an attribute of a node is a function of the values of the attributes of its children, then it is called a

- (a) synthesized attribute (b) inherited attribute
 (c) canonical attribute (d) none of the above

35. Synthesized attribute can easily be simulated by an

- (a) LL grammar (b) ambiguous grammar
 (c) LR grammar (d) none of the above

36. For which of the following situations, inherited attribute is a natural choice?

- (a) Evaluation of arithmetic expressions
 (b) Keeping track of variable declaration
 (c) Checking for the correct use of L-values and R-values
 (d) All of the above

37. The graph depicting the inter-dependencies of the attributes of different nodes in a parse tree is called a

- (a) flow graph (b) dependency graph
 (c) Karnaugh's graph (d) Steffi graph

22. A top-down parser generates
 (a) left-most derivation (b) right-most derivation
 (c) right-most derivation in reverse (d) left-most derivation in reverse
23. A bottom-up parser generates
 (a) left-most derivation (b) right-most derivation
 (c) right-most derivation in reverse (d) left-most derivation in reverse
24. A given grammar is said to be ambiguous if
 (a) two or more productions have the same non-terminal on the left hand side
 (b) a derivation tree has more than one associated sentence
 (c) there is a sentence with more than one derivation tree corresponding to it
 (d) parenthesis are not present in the grammar
- *25. The grammar $E \rightarrow E+E \mid E*E \mid a$, is
 (a) ambiguous
 (b) unambiguous
 (c) ambiguous or not depends on the given sentence
 (d) none of the above
26. Choose the correct statement.
 (a) Language corresponding to a given grammar, is the set of all strings that can be generated by the given grammar.
 (b) A given language is ambiguous if no unambiguous grammar exists for it.
 (c) Two different grammars may generate the same language.
 (d) None of the above
- *27. Consider the grammar
 $S \rightarrow ABSc \mid Abc$
 $BA \rightarrow AB$
 $Bb \rightarrow bb$
 $Ab \rightarrow ab$
 $Aa \rightarrow aa$
- Which of the following sentences can be derived by this grammar?
 (a) abc (b) aab (c) abcc (d) abbc
- *28. The language generated by the above grammar is the set of all strings, made up of a, b, c, such that
 (a) the number of a's, b's, and c's will be equal
 (b) a's always precede b's
 (c) b's always precede c's
 (d) the number of a's b's and c's are same and the a's precede b's, which precede c's.
29. In an incompletely specified automata
 (a) no edge should be labeled ϵ
 (b) from any given state, there can't be any token leading to two different states

Answers

- | | | | | |
|-------------|----------------|-----------|-----------------|--------------|
| 1. c | 2. d | 3. b | 4. a | 5. c |
| 6. d | 7. a | 8. b | 9. c | 10. a |
| 11. a, b | 12. d | 13. c | 14. d | 15. c |
| 16. c | 17. d | 18. b | 19. d | 20. c |
| 21. d | 22. a | 23. d | 24. c | 25. a |
| 26. d | 27. b | 28. d | 29. c | 30. a |
| 31. a | 32. b | 33. c | 34. d | 35. a |
| 36. c | 37. c | 38. b | 39. a, b, c | 40. c |
| 41. a | 42. c | 43. d | 44. a | 45. d |
| 46. b | 47. c | 48. c | 49. c | 50. c |
| 51. a | 52. d | 53. a | 54. a | 55. a |
| 56. c | 57. a | 58. c | 59. a | 60. a, b |
| 61. a | 62. b | 63. c | 64. a | 65. b |
| 66. c | 67. a | 68. c | 69. b | 70. a |
| 71. d | 72. a | 73. c | 74. d | 75. c |
| 76. c | 77. a, b, d | 78. a, d | 79. a, b, d | 80. d |
| 81. d | 82. b, c | 83. c | 84. c | 85. a, b, c |
| 86. a, b, c | 87. a | 88. a, b | 89. c | 90. a, d |
| 91. c, d | 92. a, b, c, d | 93. c | 94. a, d | 95. b |
| 96. a | 97. c | 98. b | 99. c | 100. b, c, d |
| 101. b, d | 102. c | 103. b | 104. c | 105. b, d |
| 106. a, d | 107. a, b | 108. c | 109. b, c | 110. a, b |
| 111. a, b | 112. c | 113. d | 114. a, b, c, d | 115. a |
| 116. c | 117. c | 118. c | 119. c | 120. d |
| 121. a | 122. d | 123. d | 124. a, b, c | 125. a |
| 126. d | 127. a | 128. d | 129. c | 130. c |
| 131. c | 132. d | 133. b, d | 134. a | 135. d |
| 136. c | 137. b | 138. a | 139. a | 140. d |
| 141. d | 142. d | 143. d | 144. b | 145. b |
| 146. a | 147. c | 148. c | 149. c | 150. b |
| 151. d | 152. a | 153. b | 154. b | 155. c |
| 156. c | 157. d | 158. c | 159. d | 160. b |
| 161. d | 162. a | 163. b | 164. d | 165. b |
| 166. c | 167. c | 168. c | 169. a | 170. d |
| 171. d | 172. a | 173. a | 174. d | 175. d |
| 176. c | 177. c | 178. c | 179. c | 180. d |

181. c	182. a	183. d	184. c	185. b
186. c	187. d	188. a	189. c	190. d
191. a	192. d	193. a	194. a	195. b
196. b	197. b	198. d	199. c	200. d
201. a	202. a	203. a	204. b	205. b
206. b	207. d	208. a	209. d	210. b
211. c	212. b	213. c	214. a	215. c
216. c	217. a	218. a		

Explanations

- ${}^{39}P_{30} / {}^{40}P_{30} = 1/4$
- Probability that the unit digit is not 7 is $9/10$.
Probability that the tens digit is not 7 is $9/10$.
Probability that the hundreds digit is not 7 is $8/9$.
So, the probability that all the three digits are not 7 is $(9/10)(9/10)(8/9) = 18/25$.
- Let $x = 0.15252525\dots$
 $1000x - 10x = 151$. So, $x = 151/990$
- The required value is, number of arrangement without restriction - number of arrangement with restriction. That is
 $(8-1)! - (7-1)! 2! = 6! (7-2) = 3600$
- The converse is also true.
- Total cases is $6 \times 6 \times 6 = 216$
For real roots $b^2 \geq 4ac$
When $b^2 = 36$, ac can't be 10, 11, 12...
When ac is 1, b can take the 5 values 2, 3, 4, 5, 6.
When ac is 2, either $a = 1, b = 2$ or $a = 2, b = 1$. When $ac = 2$, b can take the 4 values 3, 4, 5, 6. So, total $4 + 4 = 8$ possible values. Continuing this way, we find there are 43 possible cases. Hence the required probability is $43/216$.
- Including 0 occupying the most significant position, the sum will be
 $24(2 + 4 + 6 + 8)(10000 + 1000 + 100 + 10 + 1) = 24 \times 20 \times 11111$...I
Out of these, 0 occupies the most significant place in $4!$ numbers. Sum of these will be
 $(4!/4)(2 + 4 + 6 + 8)(1000 + 100 + 10 + 1) = 6 \times 20 \times 1111$...II
I - II gives the result.
- It is ${}^6C_2 \times {}^4C_2 / 2 = 45$
- $O(h)$ is 2, implies $hh = e$ (e is the identity element of the group).
Now, $(ghg^{-1})(ghg^{-1}) = gh(g^{-1}g)hg^{-1} = g(hh)g^{-1} = gg^{-1} = e$.
So, $O(ghg^{-1})$ is 2.
- $\log \sin(x) > 0 \Rightarrow \sin x > e^0 = 1$, which is impossible.

- number of grammar symbols on the left hand side of a production can't be greater than the number of terminals on the right hand side
- number of grammar symbols on the left hand side of a production can't be greater than the number of non-terminals on the right hand side
- In a context-free grammar,
 - ϵ can't be the right hand side of any production
 - terminal symbols can't be present in the left hand side of any production
 - the number of grammar symbols in the left hand side is not greater than the number of grammar symbols in the right hand side
 - all of the above
- If w is a string of terminals and A, B are two non-terminals, then which of the following are right-linear grammars?
 - $A \rightarrow Bw$
 - $A \rightarrow BwAw$
 - $A \rightarrow wBw$
 - None of the above
- If a is a terminal and S, A, B are three non-terminals, then which of the following are regular grammars?
 - $S \rightarrow \epsilon$
 - $A \rightarrow aB|a$
 - $A \rightarrow aS|b$
 - $B \rightarrow bA|b$
 - $A \rightarrow Ba|Bab$
 - $A \rightarrow abB|aB$
- Representing the syntax by a grammar is advantageous because
 - it is concise
 - it is accurate
 - automation becomes easy
 - intermediate code can be generated easily and efficiently
- CFG can be recognized by a
 - push-down automata
 - 2-way linear bounded automata
 - finite state automata
 - none of the above
- CSG can be recognized by
 - push-down automata
 - 2-way linear bounded automata
 - finite state automata
 - none of the above
- Choose the correct statements.
 - Sentence of a grammar is a sentential form without any terminals.
 - Sentence of a grammar should be derivable from the start state.
 - Sentence of a grammar should be frontier of a derivation tree, in which the root node has the start state as the label.
 - All of the above
- A grammar can have
 - a non-terminal A that can't derive any string of terminals
 - a non-terminal A that can be present in any sentential form
 - ϵ as the only symbol on the left hand side of a production
 - none of the above

For which of the following reasons, a compiler is preferable to an interpreter?

- (a) It can generate stand-alone programs that often take less time for execution.
- (b) It is much helpful in the initial stages of program development.
- (c) Debugging can be faster and easier.
- (d) If one changes a statement, only that statement needs recompilation.

The cost of developing a compiler is proportional to the

- (a) complexity of the source language
- (b) complexity of the architecture of the target machine
- (c) flexibility of the available instruction set
- (d) none of the above

An ideal compiler should

- (a) be smaller in size
- (b) take less time for compilation
- (c) be written in a high level language
- (d) produce object code that is smaller in size and executes faster

An optimizing compiler

- (a) is optimized to occupy less space
- (b) is optimized to take less time for execution
- (c) optimizes the code
- (d) none of the above

In a compiler, grouping of characters into tokens is done by the

- (a) scanner
- (b) parser
- (c) code generator
- (d) code optimizer

Whether a given pattern constitutes a token or not

- (a) depends on the source language
- (b) depends on the target language
- (c) depends on the compiler
- (d) none of the above comments is true

A grammar will be meaningless if the

- (a) terminal set and the non-terminal set are not disjoint
- (b) left hand side of a production is a single terminal
- (c) left hand side of a production has no non-terminal
- (d) left hand side of a production has more than two non-terminals

Which of the following grammars are not phase-structured?

- (a) Regular
- (b) Context-free
- (c) Context-sensitive
- (d) None of the above

Which of the following is the most general phase-structured grammar?

- (a) Regular
- (b) Context-free
- (c) Context-sensitive
- (d) None of the above

In a context-sensitive grammar,

- (a) ϵ can't be the right hand side of any production
- (b) number of grammar symbols on the left hand side of a production can't be greater than the number of grammar symbols on the right hand side

- 14. Only when $\lambda = 4$ and $\mu = 2$, we have 2 equations in three variables, giving infinitely many solutions.
- 15. Let aRb . Since the relation is symmetric, bRa . Since transitivity holds good, aRb and bRa imply bRb and aRa . If R has to be an equivalent relation, it has to be reflexive, i.e., for any x belonging to A , xRx should be valid. Hence R need not be reflexive. So it need not be an equivalent relation. For example, let $A = \{1, 2, 3\}$. Let $R = \{(1, 2), (2, 1), (1, 1), (2, 2)\}$. R is both symmetric and transitive but not reflexive as $(3, 3)$ is missing.
- 16. The set has 3 elements. So the power set has $2^3 = 8$ elements.
- 17. It is 9.
- 18. It is $\sqrt{18^2 + 6^2 + (4.5)^2}$
- 19. Out of the 8 available squares, 6 can be selected in ${}^8C_6 = 28$ ways. This includes the two possibilities which are not allowed. These two possibilities are—One with top row empty and the other with the bottom row empty. So, there are $28 - 2 = 26$ possibilities.
- 20. The required number is $100 - (10 + 20 + 15 + 10 + 12 + 5 + 8) = 20$.
- 26. Solving the three equations we get $n = 9$ and $r = 3$.
- 27. Consider the function $f(x) = x - \cos(x)$. $f(0)$ is $0 - 1 = -1$, a negative number. $f(\pi)$ is $\pi - (-1) = \pi + 1$, a positive number. So, the function will have an odd number of roots (Ref Qn. 54) in the interval $[0, \pi]$. Also, it cannot have infinitely many roots as $\cos(x)$ oscillates in $[-1, 1]$, while $(y =) x$ increases monotonically and so infinite solution is impossible. Hence the answer is option b.
- 28. It is $10^5 - {}^{10}P_5$
- 29. ${}^nC_r + {}^nC_r = {}^{(n+1)}C_r$
So, ${}^{47}C_4 + {}^{47}C_3 = {}^{48}C_4$, etc.. Using this, the given summation can be simplified to ${}^{52}C_4$
- 30. The rank of a matrix is said to be N , if the determinant value of at least 1 sub-matrix of order $N \times N$ is not 0 and all $(N + 1) \times (N + 1)$ is zero. So the rank of the given matrix is 1, as any sub-matrix of order 2×2 has 0 determinant value and (1), a sub-matrix of order 1×1 has the non-zero determinant value of 1.
- 32. The number of elements in the power set of a set with n elements is 2^n . The given set A has n elements. So, $A \times A$ will have n^2 elements. So, its power set will have 2^{n^2} elements.
- 33. It is $1 - (0.6)(0.6)(0.6) = 0.784$.
- 34. Let $f(x) = x + 1/x$.
 $f'(x) = 1 - 1/x^2$
 $f'(x) = 0 \Rightarrow x = \pm 1$
 $f''(x) = 2/x^3 > 0$, for $x > 0$. So, $x = 1$. $f'(1) = 2$
- 35. $f''(0) = 0$, as f is continuous at $x = 0$.

$$\lim_{h \rightarrow 0} f(x+h) = \lim_{h \rightarrow 0} f(x) + f(h) \Rightarrow \lim_{h \rightarrow 0} f(x) + \lim_{h \rightarrow 0} f(h) = f(x)$$

So, f is continuous for all x .

36. $f'(5) = \lim_{h \rightarrow 0} \frac{f(5+h) - f(5)}{h} = f(5) \lim_{h \rightarrow 0} \frac{f(h) - f(0)}{h} = f(5) f'(0) = 6$

38. Distinct elements of $\bigcup_{i=1}^{30} A_i = 30 \times 5/10 = 15$

Distinct elements of $\bigcup_{j=1}^N B_j = (n \times 3)/9 = n/3$

So, $n/3 = 15$ or $n = 45$

40. Given that $1, \omega, \omega^2$ are the roots of $x^3 - 1 = 0$. So, $1 + \omega + \omega^2 = 0$; $1 \times \omega \times \omega^2 = \omega^3 = 1$. The given equation being a third degree equation has 3 roots. Let it be a, b, c . We have $a + b + c = -(-3)$ and $ab + bc + ac = 3$ and $abc = -7$. Only option c satisfies all these. Verify.

41. Consider the function $\phi(x) = f(x) - 2g(x)$

$\phi(0) = \phi(1) = 2$. So, $\phi(x)$ satisfies the conditions of Roll's theorem in $[0, 1]$. So, $\phi'(x) = f'(x) - 2g'(x)$ has at least one 0 at C in $(0, 1)$

i.e., $\phi'(C) = 0 \Rightarrow f'(C) = 2g'(C)$

42. The only possibility is $f(z) \neq 2$ is true and the other two are false. So, $f^{-1}(1) = y$

43. $h'(x) = 2f(x)f'(x) + 2g(x)g'(x)$.

So, $h'(x) = 2f(x)g(x) + 2g(x)(-f(x)) = 0 \Rightarrow h(x)$ is constant. So, $h(5) = 11$

45. Let $x = i^i$ Taking log on both sides, we get $\log x = i \log (i)$.

$e^{i\theta} = \cos(\theta) + i \sin(\theta)$. Putting $\theta = \pi/2$, we get $e^{i\pi/2} = i$.

So, $\log x = i \log (e^{i\pi/2}) = i \times i\pi/2, \log(x) = -\pi/2$.

Hence $x = e^{-\pi/2}$ — a real number

47. The given decimal number can be written as

$$(1 + 2) \times 2^{12} + (1 + 2 + 4 + 8) \times 2^8 + (1 + 4) \times 2^4 + (1 + 2) = 2^{13} + 2^{12} + 2^{11} + 2^{10} + 2^9 + 2^8 + 2^6 + 2^4 + 2^1 + 2^0. \text{ This has 10 one's.}$$

49. We can arrange 1 or 2 or 3 or ... r things at a time.

Number of ways of arranging 1 at a time is n

Number of ways of arranging 2 at a time is n^2

Number of ways of arranging 3 at a time is n^3 etc.,

So, total number of possible permutations is:

$$n + n^2 + n^3 + \dots + n^r = n(n^r - 1) / (n - 1)$$

51. Apply change of base rule.

52. In an equation with rational coefficients, irrational roots and complex roots occur in pairs.

So, $\sqrt{5} + \sqrt{7} + i$ as a root implies $-\sqrt{5} + \sqrt{7} + i, -\sqrt{5} - \sqrt{7} + i, \sqrt{5} - \sqrt{7} + i, -\sqrt{5} - \sqrt{7}$

$-i, -\sqrt{5} - \sqrt{7} - i, \sqrt{5} - \sqrt{7} - i, \sqrt{5} + \sqrt{7} - i$, are also roots. An equation of degree n has exactly n roots (with possible repetition of some roots). Hence the answer.

Chapter 7

Principles of Compiler Design

In this chapter,

CFG stands for context free grammar.

DFSA stands for deterministic finite state automata.

NDFSA stands for non-deterministic finite state automata.

1. Cross-compiler is a compiler

- (a) which is written in a language that is different from the source language.
- (b) that generates object code for its host machine.
- (c) which is written in a language that is same as the source language.
- (d) that runs on one machine but produces object code for another machine.

2. Incremental-compiler is a compiler

- (a) which is written in a language that is different from the source language
- (b) that generates object code for its host machine
- (c) which is written in a language that is same as the source language
- (d) that allows a modified portion of a program to be recompiled

3. For which of the following reasons, an interpreter is preferred to a compiler?

- (a) It takes less time to execute.
- (b) It is much helpful in the initial stages of program development.
- (c) Debugging can be faster and easier.
- (d) It needs less computer resources.

57. Draw the transition diagram and verify that the string 10 from A, leads to C.
58. L is the set of all possible strings made up of 0's and 1's (including the null string). So, L U R is L, which can be generated by the regular expression $(a+b)^*$, and hence a regular language. R is not a regular expression. This can be proved by using Pumping Lemma or simply by the fact that finite state automata, that recognizes regular expressions, has no memory to record the number of 0's or 1's it has scanned. Without this information $0^{n^2}1^n$ cannot be recognized.
59. In general, a language (or equivalently the machine that recognizes it) cannot be converted to another language that is less powerful.
70. FSM is basically a language acceptor. As such, it does not have any output capability. So it cannot add and output the result.
71. This can be proved using induction.

53. By Descartes's rule of signs, the number of positive real roots can't be more than the number of changes of sign in $f(x)$, in this case 3, as there are 3 change of signs in $f(x)$. The number of negative roots can't be more than the number of change of signs in $f(-x)$, i.e., 2 in this case. So, altogether it can't have more than 5 real roots (obviously 0 is not a root). But this being a polynomial of degree 7, must have 7 roots. So, at least 2 imaginary roots must be present.
54. If you draw the graph of $f(x)$ between $x = a$ and $x = b$, it should cut the x -axis either 0 or even number of times. It will have as many roots as the number of times it is cutting the x -axis.
55. Ref Qn. 53. It cannot have more than 3 real roots. In an equation with real coefficients, imaginary roots occur in pairs. Here $f(0)$ and $f(\infty)$ are negative. So in the interval $(0, \infty)$ there can be none or even number of roots. Since $f(-1)$ is positive, it should have at least one root in $(-1, 0)$. Since $f(0)$ is negative and $f(\infty)$ is positive, it has at least 2 real roots, and not more than three. So, it has to be 3 because if it is 2, the number of imaginary roots will be 3, which is infeasible (since imaginary roots occur in pairs).
56. $f(-\infty)$ is positive and $f(+\infty)$ is also positive. But $f(0)$ is negative. So, it should have at least 1 root between $(-\infty, 0)$ and at least one root between $(0, +\infty)$.
57. The remainder on division will be a first degree polynomial. Let it be $Mx + N$. So $f(x) = (x - \alpha)(x - \beta)Q + (Mx + N)$. (Q is the quotient). Putting $x = \alpha$, $f(\alpha) = M\alpha + N$ and $f(\beta) = M\beta + N$. Solving we get the answer.
58. If the base is greater than 1, it will be $-\infty$. If the base is less than 1, it will be $+\infty$. If the base is 1, it will be undefined.
59. We have $x^n + nax - b = (x - a_1)(x - a_2) \dots (x - a_n)$
Differentiating both sides with respect to x and putting $x = a_1$, we get the result.
61. $|a - b| < n$ implies $-n < a - b < n$
 $|b - c| < m$ implies $-m < b - c < m$
Adding both these inequalities,
 $-(n + m) < a - c < n + m$, which is nothing but $|a - c| < n + m$.
63. A may win in the first or second ... or n^{th} toss. So, the required probability is $(1/2) + (1/2)^3 + (1/2)^5 + \dots$. Summation of this geometric progression is $2/3$.
64. Any number can be expressed as the product of prime numbers in a unique way. So, 200! written in this form will have a certain number of 2's and 5's. The number of 2's will be more than the number of 5's as each even number contributes at least one 2. The only way to get a 0 is to multiply a 2 by 5. The number of 5's will decide the number of zeroes. The numbers 5, 10, 15, ... 200 each contribute one 5. This totals to 40. The numbers 25, 50, 75, ..., 200 will contribute one more 5. The number 125 will contribute yet another. So, totally $40 + 8 + 1 = 49$ zeroes.
65. Consider a $n \times n$ matrix. To find the determinant, we have to multiply each element of the first row, with its cofactor. The cofactor is the determinant value of a $(n - 1) \times (n - 1)$ matrix. The number of terms in the determinant value of a $n \times n$ matrix, $T(n) = n T(n-1) = n \times (n-1) T(n-2) \dots = n!$ Here $n!$ is given as 720. So, n is 6.
67. It is defined if $|x| - x > 0$, i.e., $|x| > x$.
If $x \geq 0$, $|x| = x$. So, $x > x$, which has no feasible solution.
If $x < 0$, $|x| = -x$. So, $-x > x$, which has the solution $x < 0$.
68. The probability that the first ball drawn is white and the second black is $(10/25) \times (15/24) = 1/4$.

The probability that the first ball drawn is black and the second white is $(15/25) \times (10/24) = 14$. So, the required probability is $1/4 + 1/4 = 1/2$.

69. The iterative formula is $x_{k+1} = x_k + f(x_k) / f'(x_k)$. Here $x = \sqrt{b}$, i.e., $x^2 - b = 0$. Taking $f(x) = x^2 - b$, we get the answer.
72. The required value of x is, $x = -\sqrt{20+x}$. Solving, we get $x = -4$ or 5 .
73. $P(\bar{A} \cap \bar{B}) = 1 - P(A \cup B) = 1 - (P(A) + P(B) - P(A \cap B)) = 0.39$.
74. By Lagrange's mean value theorem, in the interval $[0,5]$, there must exist a constant C in $(0, 5)$ such that $g'(C) = (g(5) - g(0)) / (5-0) = -5/6$
76. The first element of A may be mapped to any one of the n elements of B . The second element to any one of the remaining $n - 1$ elements. Proceeding this way, the m^{th} element can be mapped to one of the remaining $(n - m + 1)$ elements of B . So, we have $n \times (n - 1) \times (n - 2) \times \dots \times (n - m + 1) = {}^n P_m$ possible ways.
77. In a set, order of the members and repetition is immaterial.
80. It is not reflexive as $-3 R -3$ is not true. It is not irreflexive as $2 R 2$ is true. It is not symmetric as $-3 R 3$, but $3 R -3$ is not true. It is anti-symmetric as, if $a R b$ and $b R a$ are both true, then $a = b$.
81. We have $1 R 2$ and $2 R 1$, but $1 R 1$ is not true. So, R is not transitive. We have $4 R 3$, but $3 R 4$ is not true. So, R is not symmetric. Also, $1 R 2$ and $2 R 1$, but $1 \neq 2$. So, R is not anti-symmetric.
82. A relation is a function if and only if each element in the domain has a unique image. (a) is not a function as the element 1 has two images 2 and 3. (d) is not a function as the element 3 in the domain has no image.
86. All three can be proved by Pigeon-hole principle.
93. The roots are given by $x = \frac{-b \pm \sqrt{b^2 - 4ac}}{2a}$
- Differentiating both sides, treating c as a variable, $dx = dc / \sqrt{b^2 - 4ac}$
- For dx to be less than 5×10^{-5} , dc should be to the accuracy of approximately 8×10^{-5} (check by putting $b = -2$, $a = 1$ and $c = \log 2$, and solving the above equation).
94. The determinant of a matrix equals the product of its eigenvalues.
95. M has n rows. If all the elements of a row are multiplied by 2, the determinant value becomes 2×5 . Multiplying all the n rows by 2, will make the determinant value $2^n \times 5 = 40$. Solving, $n = 3$.
98. To ensure 5 digit accuracy, the error term $x^{2n+2}/(2n+2)!$ should be less than 5×10^{-6} Solving, we get $n = 7$.
102. All are parallel lines, but only the second line has chances of bounding the convex region.
119. Substitute and verify. The solution can also be obtained like this—The complementary equation is $D^2 + 3D + 2 = 0$. This has $D = -1, -2$ as the roots. Hence the solution is: $C_1 e^{-x} + C_2 e^{-2x}$.

17. Here the final state and the start state are one and the same. No transition is there. But by definition, there is an (implicit) ϵ -transition from any state to itself. So, the only string that could be accepted is ϵ .
22. Refer Qn. 17. In the second diagram, the final state is unreachable from the start state. So not even ϵ could be accepted.
24. Let 011011 be the input to the FSM and let it be fed from the right (i.e., least significant digit first). If we add 1 to 011011 we should get 011100. But did we obtain it? Whenever we add 1 to an 1, we make it 0 and carry 1 to the next stage (state) and repeat the process. If we add 1 to a 0, then first make it 1 and all the more significant digits will remain the same, i.e., a 0 will be 0 and an 1 will be 1. That's what the given machine does. Hence the answer is (c).
26. Here the initial and the final states are one and the same. If you carefully examine the transition diagram, to move right you have to consume a 'b', to move left a 'b', to go up an 'a' and to go down an 'a'. Whenever we move right, we have to move left at some stage or the other, to get back to the initial-cum-final state. This implies, a 'b' essentially has an associated another 'b'. Same is the case with 'a' (since any up (down) has a corresponding down (up)). So, even number of a's and b's have to be present.
29. S is the start state. $X \rightarrow a, Y \rightarrow a$ are the only productions that could terminate a string derivable from X and Y respectively. So at least two a's have to come anyway. Hence the answer is (d).
30. We have $S \rightarrow aB \rightarrow aabb \rightarrow aabbb \rightarrow aabbb$.
So (b) is wrong. We have
 $S \rightarrow aB \rightarrow ab$
So (c) is wrong.
A careful observation of the productions will reveal a similarity. Change A to B, B to A, a to b and b to a. The new set of productions will be the same as the original set. So (d) is false and (a) is the correct answer.
32. Option (b) is wrong because it can't generate aabb (in fact any even power). Option (c) is wrong since it generates ϵ also. Both (a) and (d) are correct.
34. Option (c) generates the set $\{a^n b^n, n=1, 2, 3, \dots\}$ which is not regular. Options (a) and (b) being left linear and right linear respectively, should have equivalent regular expressions.
60. Totally there are mn bits. Each bit will be in one of the two possible states - 1 or 0. So the entire memory made up of mn bits will be in one of the possible 2^{mn} states.
62. For example, $P = a^*$; $Q = a^n b^n b^*$; $R = PQ = a^* b^*$
64. The first two options can be proved to be correct using De Morgan's laws. Option (c) can be disproved by the following counter-example. Let the universal set U be $\{a, b, c, d\}$. Let $A = \{\{a\}, \{d\}, \{a, d\}, \{b, d\}, \{a, b, d\}, \{\}\}$. A is closed under union and intersection but is not closed under complementation. For example complement of $\{a, d\}$ is $\{b, c\}$, which is not a member of A.
66. II generates strings like $xyyy$, which are not supposed to be. III generates strings like xyy , which are not supposed to be. I can be verified to generate all the strings in L and only those.

70. An FSM can be used to add two given integers. This remark is
 (a) true (b) false (c) may be true (d) none of the above
71. A CFG is said to be in Chomsky Normal Form (CNF), if all the productions are of the form $A \rightarrow BC$ or $A \rightarrow a$. Let G be a CFG in CNF. To derive a string of terminals of length x , the number of productions to be used is
 (a) $2x - 1$ (b) $2x$ (c) $2x + 1$ (d) 2^x

Answers

- | | | | | |
|-------------|----------------|-------------|-------------|---------------|
| 1. c | 2. d | 3. a, b, c | 4. b | 5. a, b, c, d |
| 6. c | 7. d | 8. b | 9. a, b, c | 10. a, b, d |
| 11. c | 12. a | 13. a | 14. a, b, c | 15. b |
| 16. c | 17. c | 18. a | 19. a | 20. a, b, c |
| 21. d | 22. d | 23. d | 24. c | 25. a, d |
| 26. c | 27. a, b, c | 28. b, c, d | 29. d | 30. a |
| 31. c | 32. a, d | 33. b, c | 34. c | 35. c |
| 36. c | 37. a, b | 38. b, c | 39. c, d | 40. a |
| 41. c | 42. a, c | 43. b | 44. d | 45. a, b |
| 46. a, b, d | 47. c | 48. d | 49. d | 50. a, d |
| 51. b | 52. a, b, c, d | 53. a, b, c | 54. a, b, c | 55. b |
| 56. d | 57. a | 58. a | 59. c | 60. b |
| 61. b | 62. c | 63. d | 64. a, b | 65. c |
| 66. a | 67. b | 68. c | 69. c | 70. b |
| 71. a | | | | |

Explanations

6. DFSM is a special case of NDFSM. Corresponding to any given NDFSM, one can construct an equivalent DFSM. Corresponding to any given DFSM, one can construct an equivalent NDFSM. So they are equally powerful.
9. Strings of odd number of zeroes can be generated by the regular expression $(00)^*0$. Pumping lemma can be used to prove the non-regularity of the other options.
10. Two regular expressions $R1$ and $R2$ are equivalent if any string that can be generated by $R1$ can be generated by $R2$ and vice-versa. In option (c), $(ab)^*$ will generate $abab$, which is not of the form $a^n b^n$ (because a's and b's should come together). All other options are correct (check it out!).
12. Pigeon-hole principle is that if ' n ' balls are to be put in ' m ' boxes, then at least one box will have more than one ball if $n > m$. Though this is obvious, still powerful.
13. That's why it can't recognize strings of equal number of a's and b's, well-formedness of nested parenthesis etc.

120. By definition $\neg P \Rightarrow Q$ is true means that $\neg(\neg P) \vee Q$ is true. The proposition $\neg P \vee (P \Rightarrow Q)$ is nothing but $\neg P \vee (\neg P \vee Q)$, i.e., $\neg P \vee Q$. The trueness or the falsity of this cannot be determined from the given proposition.
121. $600 = 5 \times 5 \times 3 \times 2 \times 2 \times 2$. Any factor of 600 can be obtained by choosing 1, 2, 3 or no two's at all, i.e., 4 ways of selecting two. Similarly, there are 2 ways of choosing 3, and 3 ways of choosing 5. So, there are altogether $4 \times 2 \times 3 = 24$ different ways. This includes 1 (corresponding to choosing no two's, no three's and no five's) as well as 600 (by choosing all the 2's, 3's and 5's).

122. It can be written as
$$\begin{pmatrix} 1 & 2 & 3 \\ 4 & 5 & 6 \\ 4+1 & 5+2 & 6+3 \end{pmatrix}$$

$$\text{So, } \begin{vmatrix} 1 & 2 & 3 \\ 4 & 5 & 6 \\ 5 & 2 & 9 \end{vmatrix} = \begin{vmatrix} 1 & 2 & 3 \\ 4 & 5 & 6 \\ 1 & 7 & 3 \end{vmatrix} + \begin{vmatrix} 1 & 2 & 3 \\ 4 & 5 & 6 \\ 4 & 5 & 6 \end{vmatrix} = 0 + 0 = 0$$

123. None of the elementary operations affects the rank.
125. The order of a subgroup should divide the order of the group. 11 being a prime number, number has no proper divisor and hence it can't have any proper sub-group.
126. We have $(AB)^t = B^t A^t$. Since A and B are symmetric matrices, $A^t = A$ and $B^t = B$. Hence the answer.
128. $P(A \cup B) = P(A) + P(B) - P(A \cap B)$
 i.e., $P(A \cup B) + P(A \cap B) = P(A) + P(B)$
 Since $P(A \cap B)$ cannot be negative, $P(A \cup B) \leq P(A) + P(B)$
130. $(x*y)^2 = (x*y)(x*y) = (x*y)(y*x) = x*(y*y)*x = x*y^2*x = x*x*y^2 = x^2*y^2$.
132. Number of strings of length 1 is n .
 Number of strings of length 2 is $n - 1$.
 Number of strings of length 3 is $n - 2$, etc.
 Number of strings of length $n - 1$ is 2.
 Number of strings of length n is 1.
 Totally, $1 + 2 + 3 \dots + n = n(n+1) / 2$
134. We have $2R5$ and $5R2$. If it is transitive, then $2R2$, but it is not, as $2R2$ means 2 is not equal to 2, which is wrong.
136. $A = (A \cap B) \cup (A \cap \bar{B})$.
 $P(A) = P(A \cap B) + P(A \cap \bar{B})$
 $= Q + R$
142. 1 is the identity element as $1 \text{ LCM } a = a \text{ LCM } 1 = a$, for any a belonging to the set. What is the inverse of 3? If it is y , then $3 \text{ LCM } y = y \text{ LCM } 3 = 1$. No such y can be found.
143. 24 is the identity element, as $24 \text{ GCD } x = x \text{ GCD } 24 = x$, for any x belonging to the set. But inverse doesn't exist.

145. The total number of possible functions is n^m . If it is to be 10, then $n = 10$ and $m = 1$.
147. $g(-x) = f(-x)[f(-x) + f(x)]$. If f is even then $f(-x) = f(x)$.
So, $g(-x) = f(x)[f(x) + f(-x)] = g(x)$. Hence g is even if f is even.
150. ω is a generator, as all the cube roots of unity can be expressed as powers of ω .
For similar reasons, ω^2 is also a generator, as $\omega = (\omega^2)^2$ and $1 = (\omega^2)^3$.
151. $x \log x = \log x / (1/x)$. Apply L'Hospital's rule.
152. Whenever $f(a)$ and $f(b)$ are of different signs, then f has odd number of roots (at least one) between a and b .
153. Let $S = x + 2x^2 + 3x^3 + \dots$
 $xS = x^2 + 2x^3 + \dots$
 $S - xS = x + x^2 + x^3 + \dots = x(1 - x^n) / (1 - x) = x / (1 - x)$
 $(1 - x)S = x / (1 - x)$. So, $S = x / (1 - x)^2$.
Another way of doing this is:
 $S / x = \sum kx^{k-1} = d/dx \sum x^k = d/dx [x/(1 - x)] = 1/(1 - x)^2$
So $S = x / (1 - x)^2$
154. A linear transformation F satisfies $F(mx, my) = mF(x, y)$ and $F(a + b, c + d) = F(a, c) + F(b, d)$. Option (b) does not satisfy this while the others do.
155. Eigenvalue m satisfies the equation $|A - mI| = 0$. Put $m = 0$. We get $|A| = 0$, which is given to be true. So, $m = 0$ is an eigenvalue.
165. Each print is a k -tuple I_1, I_2, \dots, I_k — such that $N \geq I_1 \geq I_2 \geq \dots \geq I_k \geq 1$.
Hence the problem reduces to choosing k integers, with repetitions allowed, from $1, 2, 3, \dots, N$ — which is ${}^{k+N-1}C_k$. This is because any such selection, if written in ascending order will satisfy the conditions and any solution will be a selection.
170. Square of an odd number is an odd number. Square of an even number is an even number. If you add two odd numbers, you get an even number. As a result, $(\text{odd number})^2 + (\text{odd number})^2 = \text{even number}$. Since no even number can be a square of an odd number, options a, b, and c, cannot be correct.
171. Square of an odd number is an odd number. Square of an even number is an even number. If you add two even numbers, you get an even number. As a result, $(\text{even number})^2 + (\text{even number})^2 = \text{even number}$. Since no even number can be a square of an odd number, options a, b, and c, cannot be correct.
172. You can verify by constructing truth table for an implication, say, $P \rightarrow Q$ and its contrapositive $\neg Q \rightarrow \neg P$
174. Let us prime factorize the number. 637245 is $5 \times 3 \times 3 \times 7 \times 7 \times 17 \times 17$. The word we are looking for must have the letter corresponding to 17, which is Q.
175. Let us prime factorize the number. $124950 = 5 \times 5 \times 2 \times 3 \times 7 \times 7 \times 17$. The word we are looking for must have the letter corresponding to 17, which is Q. It is not a bad idea to guess Q will be immediately followed by a U. The code for U is 21. We are left with $5 \times 5 \times 2 \times 7$. If the remaining letters are 4, it has to be E, E, B, G. But there is no 6-letter word with the letters Q, U, E, E, B, G. So, let us assume that there are only 3 remaining letters. The possible codes for these 3 letters are — (25,2,7), (10,5,7), (5,5,14). This means the possible

64. Choose the correct statements.
A class of languages that is closed under
(a) union and complementation has to be closed under intersection
(b) intersection and complementation has to be closed under union
(c) union and intersection has to be closed under complementation
(d) all of the above
65. The following grammar is
 $S \rightarrow a\alpha b \mid b\alpha c \mid aB$
 $S \rightarrow aS \mid b$
 $S \rightarrow \alpha bb \mid ab$
 $b\alpha \rightarrow bdb \mid b$
(a) context free (b) regular (c) context sensitive (d) LR (k)
- *66. Which of the following definitions generates the same language as L, where $L = \{x^n y^n, n \geq 1\}$?
I. $E \rightarrow xEy \mid xy$
II. $xy \mid x^*xyy^*$
III. x^*y^*
(a) I only (b) I and II (c) II and III (d) II only
- *67. A finite state machine with the following state table has a single input x and a single output z .
- | Present state | Next state, z | |
|---------------|-----------------|---------|
| | $x = 1$ | $x = 0$ |
| A | D, 0 | B, 0 |
| B | B, 1 | C, 1 |
| C | B, 0 | D, 1 |
| D | B, 1 | C, 0 |
- If the initial state is unknown, then the shortest input sequence to reach the final state C is
(a) 01 (b) 10 (c) 101 (d) 110
- *68. Let $A = \{0, 1\}$ and $L = A^*$. Let $R = \{0^n 1^n, n > 0\}$. The languages $L \cup R$ and R are respectively
(a) regular, regular (b) not regular, regular
(c) regular, not regular (c) not regular, not regular
- *69. Which of the following conversion is not possible algorithmically?
(a) Regular grammar to context free grammar
(b) Non-deterministic FSA to deterministic FSA
(c) Non-deterministic PDA to deterministic PDA
(d) Non-deterministic Turing machine to deterministic Turing machine

- (c) Recursive languages are closed under complementation.
 (d) None of the above.
16. Pick the correct answers.
 Universal TM influenced the concept of
 (a) stored-program computers
 (b) interpretive implementation of programming languages
 (c) computability
 (d) none of the above
17. The number of internal states of a UTM should be at least
 (a) 1 (b) 2 (c) 3 (d) 4
18. The number of symbols necessary to simulate a TM with m symbols and n states is
 (a) $m + n$ (b) $8mn + 4m$ (c) mn (d) $4mn + m$
19. Any TM with m symbols and n states can be simulated by another TM with just 2 symbols and less than
 (a) $8mn$ states (b) $4mn + 8$ states (c) $8mn + 4$ states (d) mn states
20. The statement — "A TM can't solve halting problem" is
 (a) true (b) false
 (c) still an open question (d) none of the above
21. If there exists a TM which when applied to any problem in the class, terminates if the correct answer is yes, and, may or may not terminate otherwise is said to be
 (a) stable (b) unsolvable (c) partially solvable (d) unstable
22. The number of states of the FSM, required to simulate the behaviour of a computer, with a memory capable of storing ' m ' words, each of length ' n ' bits is
 (a) $m \times 2^n$ (b) 2^{mn} (c) 2^{m+n} (d) none of the above
23. The vernacular language English, if considered a formal language, is a
 (a) regular language (b) context free language
 (c) context sensitive language (d) none of the above
24. Let P, Q, and R be three languages. If P and R are regular and if $PQ = R$, then
 (a) Q has to be regular (b) Q cannot be regular
 (c) Q need not be regular (d) Q has to be a CFL
25. Consider the grammar
 $S \rightarrow PQ \mid SQ \mid PS$
 $P \rightarrow x$
 $Q \rightarrow y$
- To get a string of n terminals, the number of productions to be used is
 (a) n^2 (b) $n + 1$ (c) $2n$ (d) $2n - 1$

- letters are — (Y, B, G), (J, E, G), (E, E, N). Remember Q and U are the other 2 letters. It is not difficult to find (E, E, N) is the correct one and the word is QUEEN.
176. Let us prime factorize the number. $3135 = 3 \times 5 \times 11 \times 19$. The alphabet with the code 19 must be present in the word we are looking for. It is S. The alphabet with the code 11 must also be present in the word we are looking for. It is K. We are left with the factors — 3 and 5. They may account for the single alphabet O (this has the code 15) or they may account for the alphabets — C and E. Let us pursue our search with the alphabet O. We are looking for a word made up of the letters — S, K, O. No such word exists. Since 3125 is same as 3125×1 , the alphabet with code 1 can be used. So the alphabet A can also be used. So, we are looking for a word made up of S, K, O, A. The word is SOAK. If 3 and 5 account for the alphabets — C and E, we are looking for a word made up of S, K, C, E. Since the alphabet A can also be used, the word is CAKES.
177. Let us prime factorize the number. $1265 = 5 \times 11 \times 23$. The alphabet with the code 23 must be present in the word we are looking for. It is W. The alphabet with the code 11 must also be present in the word we are looking for. It is K. We are left with the factor 5. It represents the alphabet E. We are looking for a word made up of the letters—W, K, E. No such word exists. Including the alphabet A, we are looking for a word made up of the letters—W, K, E and A. It could be WEAK or WAKE.
178. The largest 10-digit number is 9876543210, which is not the correct answer as it is not divisible by 4. Note that a number is divisible by 4 if the last two digits are divisible by 4. The number we are looking for cannot be got by swapping the 1 and 0. Let us try permuting the last 3 digits—2, 1, and 0. Since we are for the largest number, we need to try in the order—120, 102, 021, 012. Since 120 is divisible by 4, the correct answer is 9876543120.
179. The largest 10-digit number is 9876543210, which is not the correct answer as it is not divisible by 8. Note that a number is divisible by 8 if the last three digits are divisible by 8. The number we are looking for cannot be got by swapping the 1 and 0. Let us try permuting the last 3 digits—2, 1, and 0. Since we are looking for the largest number, we need to try in the order—120, 102, 021, 012. Since 120 is divisible by 8, the correct answer is 9876543120.
180. The smallest 10-digit positive number is 1023456789, which is not the correct answer as it is not divisible by 8. Note that a number is divisible by 8 if the last three digits are divisible by 8. The number we are looking for cannot be got by swapping the 1 and 0. Let us try permuting the last 3 digits—7, 8, and 9. Since we are for the smallest number, we need to try in the order—789, 798, 879, 897, 978, 987. none of these is divisible by 8. Let us enlarge our search domain by permuting the last 4 digits—6, 7, 8, and 9. We need to try in the order—6789, 6798, 6879, 6897, 6978, 6987, 7689, 7698, 7869, 7896, 7968, 7986 etc., The first number in this order that is divisible by 8 is 7896. So, the number we are looking for is 1023457896.
181. A number is divisible by 11 if the difference of the sum of the numerals in the odd numbered positions and the sum of the numerals in the even numbered positions is divisible by 11. Consider the largest number—9876543210. The sum of the numerals in the odd numbered positions is 25 ($9+7+5+3+1$). The sum of the numerals in the even numbered positions is 20 ($8+6+4+2+0$). The difference is 5, which is not divisible by 11. So, 9876543210 is not divisible by 11. We have to permute the numerals so that the sum of the numerals in the odd numbered positions becomes 28. This is because the sum of the numerals in the even numbered positions will then become 17, making the difference 11, which is divisible by 11. This

can be achieved by swapping 4 and 1. The number is 9876513240. This is divisible by 11. The numerals in the odd numbered positions are 9, 7, 5, 3, 4. Arranging them descending order (because we are in the look out for the largest number), we get 9, 7, 5, 4, 3, as the correct order of the numerals in the odd numbered positions. Doing the same with numerals in the even numbered positions, the correct order of the numerals in the even numbered positions will be 8, 6, 2, 1, 0. Therefore the largest 10-digit integer, containing all the numerals 1,2,3,4,5,6,7,8,9,0 that is divisible by 11 is 9876524130.

185. Each cut should give him a face of the cube. A cube has 6 faces.
 186. To get as many pieces as possible, each line must cut all the existing lines at the non-intersecting points.



187. To get as many pieces as possible, each line must cut all the existing lines at non-intersecting points.



188. A diagram will make it easy to comprehend.



It is easy to find that the can labeled 25 Paise must have 5 paise coins in it. So, the can labeled 10 Paise, must have 25 paise coins in it.

189. The can labeled 5/10 paise.
 A diagram will make it easy to comprehend.



The can labeled 5/10 Paise will have either all 5 paise or all 10 paise. If the coin you inspected is a 5-paise coin, the can labeled 5 Paise must have the 10 Paise coins in it. If the coin you inspected is a 10 Paise coin, that is the can you are looking for.

45. Choose the correct statements.
 (a) An FSM with 1 stack is more powerful than an FSM with no stack.
 (b) An FSM with 2 stacks is more powerful than a FSM with 1 stack.
 (c) An FSM with 3 stacks is more powerful than an FSM with 2 stacks.
 (d) All of these.
46. Choose the correct statements.
 (a) An FSM with 2 stacks is as powerful as a TM.
 (b) DFSM and NDFSM have the same power.
 (c) A DFSM with 1 stack and an NDFSM with 1 stack have the same power.
 (d) A DFSM with 2 stacks and an NDFSM with 2 stacks have the same power.
47. Bounded minimalization is a technique for
 (a) proving whether a primitive recursive function is Turing computable
 (b) proving whether a primitive recursive function is a total function
 (c) generating primitive recursive functions
 (d) generating partial recursive functions
48. Which of the following is not primitive recursive but computable?
 (a) Carnot function
 (b) Riemann function
 (c) Bounded function
 (d) Ackermann function
49. Which of the following is not primitive recursive but partially recursive?
 (a) Carnot function
 (b) Riemann function
 (c) Bounded function
 (d) Ackermann function
50. Choose the correct statements.
 (a) A total recursive function is also a partial recursive function.
 (b) A partial recursive function is also a total recursive function.
 (c) A partial recursive function is also a primitive recursive function.
 (d) A primitive recursive function is also a partial recursive function.
51. A language L for which there exists a TM, T, that accepts every word in L and either rejects or loops for every word that is not in L, is said to be
 (a) recursive
 (b) recursively enumerable
 (c) NP-HARD
 (d) none of the above
52. Choose the correct statements.
 (a) $L = \{a^n b^n a^n \mid n=1, 2, 3, \dots\}$ is recursively enumerable.
 (b) Recursive languages are closed under union.
 (c) Every recursive language is recursively enumerable.
 (d) Recursive languages are closed under intersection.
53. Choose the correct statements.
 (a) Set of recursively enumerable languages is closed under union.
 (b) If a language and its complement are both regular, then the language must be recursive.

35. CFG is not closed under
 (a) union (b) Kleene star (c) complementation (d) product
36. The set $A = \{a^n b^n a^n \mid n = 1, 2, 3, \dots\}$ is an example of a grammar that is
 (a) regular (b) context free
 (c) not context free (d) none of the above
37. Let $L1 = \{a^m b^n a^m \mid m, n = 1, 2, 3, \dots\}$
 $L2 = \{a^n b^m a^m \mid m, n = 1, 2, 3, \dots\}$
 $L3 = \{a^n b^n a^n \mid n = 1, 2, 3, \dots\}$
 Choose the correct statements.
 (a) $L3 = L1 \cap L2$
 (b) $L1$ and $L2$ are CFL but $L3$ is not a CFL
 (c) $L1$ and $L2$ are not CFL but $L3$ is a CFL
 (d) $L1$ is a subset of $L3$
38. $L = \{a^n b^n a^n \mid n = 1, 2, 3, \dots\}$ is an example of a language that is
 (a) context free
 (b) not context free
 (c) not context free but whose complement is CF
 (d) context free but whose complement is not CF
39. The intersection of a CFL and a regular language
 (a) need not be regular (b) need not be context free
 (c) is always regular (d) is always CF
40. A PDM behaves like an FSM when the number of auxiliary memory it has is
 (a) 0 (b) 1 (c) 2 (d) none of the above
41. A PDM behaves like a TM when the number of auxiliary memory it has is
 (a) 0 (b) 1 or more (c) 2 or more (d) none of the above
42. Choose the correct statements.
 (a) The power of DFSM and NDFSM are the same.
 (b) The power of DFSM and NDFSM are different.
 (c) The power of DPDM and NDPDM are different.
 (d) The power of DPDM and NDPDM are the same.
43. Which of the following is accepted by an NDPDM, but not by a DPDM?
 (a) All strings in which a given symbol is present at least twice.
 (b) Even palindromes (i.e. palindromes made up of even number of terminals).
 (c) Strings ending with a particular terminal.
 (d) None of the above
44. CSG can be recognized by a
 (a) FSM (b) DPDM
 (c) NDPDM (d) linearly bounded memory machine

190. There are $5!$ ways of distributing the 5 letters to the 5 envelopes. Out of these, there is only one way that correctly distributes the letters to the envelopes.
191. In 1 hour, Priya can walk to her school 10 times.
192. Let m be the number of tests he took. His average is $\frac{45 + (m - 9) \times 10}{m}$
 Equating the average to 9 and solving for m , we get $m = 45$.
193. $A = 6$, $B = 8$, $X = 5$, and $Y = 9$ is another possible answer.
194. 1 machine can cut 10 papers in 10 minutes.
 1 machine can cut 1 paper in 1 minute.
 20 machines can cut 20 papers in 1 minute.
 20 machines can cut 200 papers in 10 minutes.
 Another way to reason out is to consider the 20 machines as two groups of 10 machines each. Each group can cut 100 papers in 10 minutes. So, together they can cut 200 papers in 10 minutes. So, the statement—10 machines can cut 100 papers in 10 minutes, expressed algebraically is, 100 machine-minutes is equivalent to 100 papers. The question expressed algebraically is, finding the number of minutes (let us call it) m , such that $20 \times m = 200$.
195. 1 machine can cut 10 papers in 10 minutes.
 1 machine in 1 minute can cut 1 paper.
 5 machines in 1 minute can cut 5 papers.
 5 machines in 60 minutes can cut 300 papers.
 Another way to reason out is to understand the fact that what could be done by 5 machines in 1 hour is essentially same what could be done by 10 machines in 30 minutes.
 So, the statement—10 machines can cut 100 papers in 10 minutes, expressed algebraically is, 100 machine-minutes is equivalent to 100 papers. The question expressed algebraically is, what is the equivalent of 300 machine-minutes (the 300 is 5 machines \times 60 minutes).
196. It is obvious that Varma runs faster than Patil. By the time Varma finished running 80 meters, Patil could run only 70 meters. By giving a head start of 10 meters, they will be tied when they are 20 meters to the finish line. Since Varma runs faster than Patil, he will cover the remaining 20 meters before Patil.
197. The least common multiple of 5, 7, and 9 is 315. If the six-digit number 123ABC is exactly divisible by 5, 7, and 9, it has to be a multiple of 315. The number 123ABC can be written as $123000 + ABC$. Dividing 123000 by 315 leaves the remainder 150. So, ABC must leave a remainder of 165 when divided by 315. This gives us the number 123165. Adding 315 or any multiple of it still gives us a number exactly divisible by 5, 7, and 9. So, there are 3 possible numbers – 123165, 123480 ($123165 + 315$), and 123795 ($123165 + 315 + 315$).
198. Let the length of the train be A .
 $A = 1/20$ km.
 Let the length of the tunnel be C .
 $A + C = 1/2$ km.
 So, the length of the tunnel is $9/20$ km. i.e., 450 meters.

199. First assume only Mani's statement is true. The story with this assumption reads ...
 Subbu ate it. Joshi didn't eat it. Kumar ate it...
 This is a contradiction. So Mani's statement is not true.
 Assume only Subbu's statement is true. The story with this assumption reads ...
 Subbu didn't eat it. Joshi ate it. Kumar ate it...
 This is also a contradiction. So Subbu's statement is also not true.
 Assume only Kumar's statement is true. The story with this assumption reads ...
 Subbu didn't eat it. Joshi didn't eat it. Kumar didn't eat it. Joshi ate it.
 This is also a contradiction. So Joshi's statement is also not true.
 Assume only Joshi's statement is true. The story with this assumption reads ...
 Subbu didn't eat it. Joshi didn't eat it. Kumar ate it. Joshi didn't eat it.
 This is not a contradiction. So Joshi's statement is the true statement. Accordingly, Kumar ate it.

200. Addition of two 2-digit numbers cannot be greater than 198. So, C is 1.
 AB can be written as $10A + B$.
 So, $AB + BA = 1A1$ can be written as $(10A + B) + (10B + A) = 100 + 10A + 10B + A$
 Simplifying,
 $11B = 101 - A$
 Since 11B is a multiple of 11, 101-A has to be a multiple of 11. This can happen only if A is 2. So, C=1, A=2, B=9. Hence A + B + C is 12.

201. Fill the 5 liter can.
 Pour it into the 3 liter can.
 The 5 liter can will be left with 2 liters of water.
 Empty the 3 liter can.
 Transfer the 2 liters in the 5 liter can to the 3 liter can.
 The 5 liter can is now empty.
 Fill it from the bucket.
 Fill the 3 liter can (which is having 2 liter now) from the 5 liter can.
 What is left in the 5 liter can will be 4 liters.

202. No generality is lost by assuming, Raman ran towards the closer end of the tunnel, say A, and Gopal ran towards the farther end of the tunnel, say B. Let the length of the tunnel be y miles. Time taken by Raman to reach the end of the tunnel is $2y/75$ hours (since distance traveled is $2y/5$ and the speed is 15 miles/hour). Time taken by Gopal to reach the far end of the tunnel is $3y/75$ hours (since distance traveled is $3y/5$ and the speed is 15 miles/hour).

The train entered the tunnel when Raman just reached it and the train was at the other end of the tunnel when Gopal just reached it. This means the train took $3y/75 - 2y/75 = y/75$ hours to cover the tunnel.

Speed of the train = Distance covered / Time taken to cover

Distance covered is y miles.

Time taken is $y/75$.

Therefore, the speed of the train is 75 miles/hour.

28. The following CFG

$$S \rightarrow aS \mid bS \mid a \mid b$$

is equivalent to the regular expression

- (a) $(a^*+b)^*$ (b) $(a+b)^*$ (c) $(a+b)(a+b)^*$ (d) $(a+b)^*(a+b)$

***29.** Any string of terminals that can be generated by the following CFG

$$S \rightarrow XY$$

$$X \rightarrow aX \mid bX \mid a$$

$$Y \rightarrow Ya \mid Yb \mid a$$

- (a) has at least one b (b) should end in an 'a'
 (c) has no consecutive a's or b's (d) has at least two a's

***30.** The following CFG

$$S \rightarrow aB \mid bA$$

$$A \rightarrow b \mid aS \mid bAA$$

$$B \rightarrow b \mid bS \mid aBB$$

generates strings of terminals that have

- (a) equal number of a's and b's
 (b) odd number of a's and odd number b's
 (c) even number of a's and even number of b's
 (d) odd number a's and even number of a's

31. Let $L(G)$ denote the language generated by the grammar G . To prove set $A = L(G)$,

- (a) it is enough to prove that an arbitrary member of A can be generated by grammar G
 (b) it is enough to prove that an arbitrary string generated by G , belongs to set A
 (c) both the above comments (a) and (b) are to be proved
 (d) either of the above comments (a) or (b) is to be proved

***32.** The set $\{a^n b^n \mid n = 1, 2, 3, \dots\}$ can be generated by the CFG

(a) $S \rightarrow ab \mid aSb$ (b) $S \rightarrow aaSbb \mid ab$

(c) $S \rightarrow ab \mid aSb \mid \epsilon$ (d) $S \rightarrow aaSbb \mid ab \mid aabb$

33. Choose the correct statements.

- (a) All languages can be generated by CFG.
 (b) Any regular language has an equivalent CFG.
 (c) Some non-regular languages can't be generated by any CFG.
 (d) Some regular languages can't be generated by any CFG.

***34.** Which of the following CFG's can't be simulated by an FSM?

(a) $S \rightarrow Sa \mid a$

(b) $S \rightarrow abX$

$X \rightarrow cY$

$Y \rightarrow d \mid aX$

(c) $S \rightarrow aSb \mid ab$

(d) None of the above

19. The above machine
- (a) complements a given bit pattern (b) generates all strings of 0's and 1's
 (c) adds 1 to a given bit pattern (d) none of the above
20. The language of all words (made up of a's and b's) with at least two a's can be described by the regular expression
- (a) $(a+b)^*a(a+b)^*a(a+b)^*$ (b) $(a+b)^*ab^*a(a+b)^*$
 (c) $b^*ab^*a(a+b)^*$ (d) $a(a+b)^*a(a+b)^*(a+b)^*$
21. Which of the following pairs of regular expression are not equivalent?
- (a) $(ab)^*a$ and $a(ba)^*$ (b) $(a+b)^*$ and $(a^*+b)^*$
 (c) $(a^*+b)^*$ and $(a+b)^*$ (d) none of the above

*22. Consider the two FSM's in Fig. 6.3.

Pick the correct statement.

- (a) Both are equivalent
 (b) The second FSM accepts only ϵ
 (c) The first FSM accepts nothing
 (d) None of the above

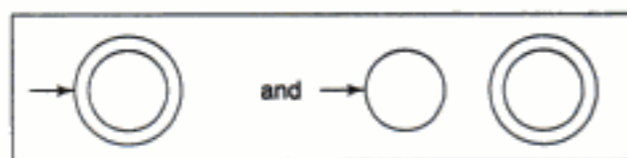

Fig. 6.3

23. Set of regular languages over a given alphabet set, is not closed under

- (a) union (b) complementation
 (c) intersection (d) none of the above

*24. The machine pictured in Fig. 6.4.

- (a) complements a given bit pattern
 (b) finds 2's complement of a given bit pattern
 (c) increments a given bit pattern by 1
 (d) changes the sign bit

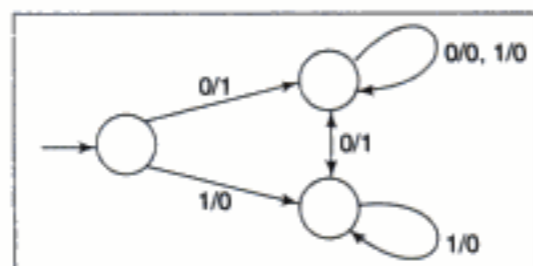

Fig. 6.4

25. For which of the following applications regular expressions can't be used?

- (a) Designing compilers (b) Developing text editors
 (c) Simulating sequential circuits (d) Designing computers

*26. The FSM pictured in Fig. 6.5 recognizes

- (a) any string of odd number of a's
 (b) any string of odd number of a's and even number of b's
 (c) any string of even number of a's and even number of b's
 (d) any string of even number of a's and odd number of b's

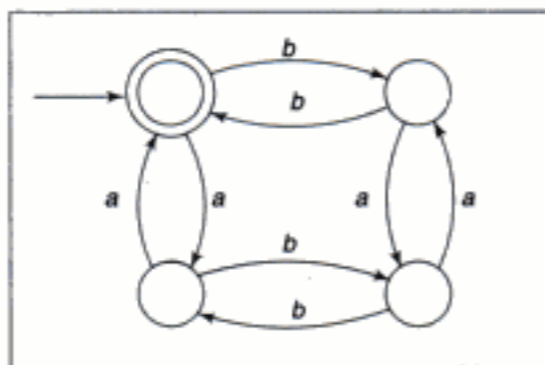

Fig. 6.5

27. Any given Transition graph has an equivalent

- (a) regular expression (b) DFSM
 (c) NDFSM (d) none of the above

203. Let us call the bulbs A, B, and C. Switch on one of them, say A. Wait for a couple of minutes and switch it off. Now, switch on another bulb, say B, and enter the room. The bulb that is glowing corresponds to the switch B. Touch the other 2 bulbs. The one that is warmer corresponds to the switch A. The left out bulb corresponds to the switch C.
204. Find the time taken for the bikes to collide. It is 2 hours. Distance traveled by the bird in 2 hours is, 200km.
205. The standard weights are 1kg, 3kg, and 4kg.
206. The shortest distance between the two squares is 10m. To cover this distance using the minimum number of metal sheets, the sheets have to be welded diagonally. The diagonal measures $\sqrt{2}$. So, we need $10/\sqrt{2}$ sheets. So, we need 8 sheets.
208. The weights are 1kg, 3kg, 9kg, and 27kg. With these weights he can weigh anything between 1 - 40kg as a whole number.
209. $P(A \cup B) = P(A) + P(B) - P(A \cap B)$
 $P(A \cap B) = 0.5 + 0.6 - 0.7 = 0.4$
212. $f'(x) = 4x - 2$. $f(x)$ increases if $f'(x) > 0$. i.e., $f(x)$ increases if $x > 1/2$. So, maximum value is attained at $x = 2$.
213. $\sqrt{2r^2 + 2r + 4} = r + 3$. Solving, $r = 5$ or -1 . Since negative radix is illogical, $r = 5$.
214. $\{(1,1), (2,2), (3,3), (4,4)\}$ is an equivalence relation and part (subset) of any other set that is an equivalence relation, as any equivalence relation has to be reflexive.
- We cannot construct another equivalence relation by adding a single ordered pair as symmetric property should hold good. Let us find how many equivalence relations can be got by adding 2 ordered pairs. If we add $(1,2)$, we need to add $(2,1)$, to satisfy the symmetric property. Since there are 4 elements, 2 elements can be selected in ${}^4C_2 = 6$ ways. Similarly, some equivalence relations can be got by adding 4 ordered pairs, like adding $(1,2), (2,1), (3,4), (4,3)$. Possible cases covered under these category is ${}^4C_2 / 2 = 3$ ways. Likewise the number of possible equivalence relations that can be got by adding 6 ordered pairs, like $(1,2), (2,3), (3,1), (2,1), (3,2), (1,3)$, will be ${}^4C_3 = 4$. There is only one possible equivalence relation by adding 8 ordered pairs. So, totally 15 possible equivalence relations can be got.

Chapter 5

Operating Systems

- Virtual memory is
 - an extremely large main memory
 - an extremely large secondary memory
 - an illusion of an extremely large memory
 - a type of memory used in super computers
- Spatial locality refers to the problem that once a location is referenced
 - it will not be referenced again
 - it will be referenced again
 - a nearby location will be referenced soon
 - none of the above
- Which of the following is an example of a SPOOLED device?
 - The terminal used to enter the input data for a program being executed.
 - The secondary memory device in a virtual memory system.
 - A line printer used to print the output of a number of jobs.
 - None of the above.
- Page fault occurs when
 - the page is corrupted by application software
 - the page is in main memory
 - the page is not in main memory
 - one tries to divide a number by 0
- Overlay is
 - a part of an operating system
 - a specific memory location
 - a single contiguous memory that was used in the olden days for running large programs by swapping.
 - overloading the system with many user files

- Choose the correct statements.
 - $A = \{a^n b^n \mid n=0, 1, 2, 3, \dots\}$ is a regular language.
 - The set B, consisting of all strings made up of only a's and b's having equal number of a's and b's defines a regular language.
 - $L(A^*B^*) \cap B$ gives the set A.
 - None of the above
- Pick the correct statements.

The logic of Pumping lemma is a good example of

 - the Pigeon-hole principle
 - the divide and conquer technique
 - recursion
 - iteration
- The basic limitation of an FSM is that
 - it can't remember arbitrary large amount of information
 - it sometimes recognizes grammars that are not regular
 - it sometimes fails to recognize grammars that are regular
 - all of the above
- Palindromes can't be recognized by any FSM because
 - an FSM can't remember arbitrarily large amount of information
 - an FSM can't deterministically fix the mid-point
 - even if the mid-point is known, an FSM can't find whether the second half of the string matches the first half
 - none of the above
- An FSM can be considered a TM
 - of finite tape length, rewinding capability and unidirectional tape movement
 - of finite tape length, without rewinding capability and unidirectional tape movement
 - of finite tape length, without rewinding capability and bidirectional tape movement
 - of finite tape length, rewinding capability and bidirectional tape movement
- TM is more powerful than FSM because
 - the tape movement is confined to one direction
 - it has no finite state control
 - it has the capability to remember arbitrary long sequences of input symbols.
 - none of the above
- The FSM pictured in Fig. 6.1 recognizes
 - all strings
 - no string
 - ϵ - alone
 - none of the above
- The FSM pictured in Fig. 6.2 is a
 - Mealy machine
 - Moore machine
 - Kleene machine
 - none of the above

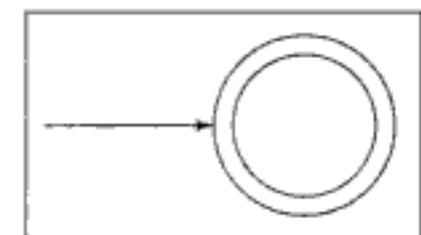

Fig. 6.1

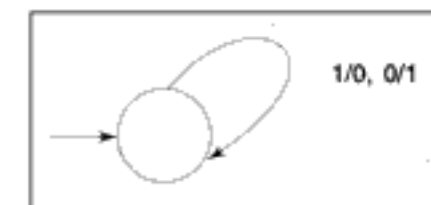

Fig. 6.2

2. Let $A = \{0, 1\}$. The number of possible strings of length ' n ' that can be formed by the elements of the set A is
 (a) $n!$ (b) n^2 (c) n^n (d) 2^n
3. Choose the correct statements.
 (a) Moore and Mealy machines are FSM's with output capability.
 (b) Any given Moore machine has an equivalent Mealy machine.
 (c) Any given Mealy machine has an equivalent Moore machine.
 (d) Moore machine is not an FSM.
4. The major difference between a Moore and a Mealy machine is that
 (a) the output of the former depends on the present state and the current input
 (b) the output of the former depends only on the present state
 (c) the output of the former depends only on the current input
 (d) none of the above
5. Choose the correct statements.
 (a) A Mealy machine generates no language as such.
 (b) A Moore machine generates no language as such.
 (c) A Mealy machine has no terminal state.
 (d) For a given input string, length of the output string generated by a Moore machine is one more than the length of the output string generated by that of a Mealy machine.
- *6. The recognizing capability of NDFSM and DFSM
 (a) may be different (b) must be different
 (c) must be the same (d) none of the above
7. FSM can recognize
 (a) any grammar (b) only CFG
 (c) any unambiguous grammar (d) only regular grammar
8. Pumping lemma is generally used for proving
 (a) a given grammar is regular
 (b) a given grammar is not regular
 (c) whether two given regular expressions are equivalent
 (d) none of the above
- *9. Which of the following are not regular?
 (a) String of 0's whose length is a perfect square.
 (b) Set of all palindromes made up of 0's and 1's.
 (c) Strings of 0's, whose length is a prime number.
 (d) String of odd number of zeroes.
- *10. Which of the following pairs of regular expressions are equivalent?
 (a) $1(01)^*$ and $(10)^*1$ (b) $x(xx)^*$ and $(xx)^*x$
 (c) $(ab)^*$ and a^*b^* (d) x^* and x^*x^*

6. Determine the number of page faults when references to pages occur in the order - 1, 2, 4, 5, 2, 1, 2, 4. Assume that the main memory can accommodate 3 pages and the main memory already has the pages 1 and 2, with page 1 having been brought earlier than page 2. (Assume LRU algorithm is used)
 (a) 3 (b) 5 (c) 4 (d) none of the above
7. Concurrent processes are processes that
 (a) do not overlap in time
 (b) overlap in time
 (c) are executed by a processor at the same time
 (d) none of the above
8. The page replacement policy that sometimes leads to more page faults when the size of the memory is increased is
 (a) FIFO (b) LRU
 (c) no such policy exists (d) none of the above
9. The only state transition that is initiated by the user process itself is
 (a) block (b) dispatch (c) wakeup (d) none of the above
10. Working set (t, k) at an instant of time, t , is the set of
 (a) k future references that the operating system will make
 (b) future references that the operating system will make in the next ' k ' time units
 (c) k references with high frequency
 (d) pages that have been referenced in the last k time units
11. Fragmentation is
 (a) dividing the secondary memory into equal sized fragments
 (b) dividing the main memory into equal-sized fragments
 (c) fragments of memory words used in a page
 (d) fragments of memory words unused in a page
12. Which of the following are real-time systems?
 (a) An on-line railway reservation system (b) A process control system
 (c) Aircraft control system (d) Payroll processing system
13. Dijkstra's banking algorithm in an operating system solves the problem of
 (a) deadlock avoidance (b) deadlock recovery
 (c) mutual exclusion (d) context switching
14. In paged memory systems, if the page size is increased, then the internal fragmentation generally
 (a) becomes less (b) becomes more
 (c) remains constant (d) none of the above
- *15. An operating system contains 3 user processes each requiring 2 units of resource R. The minimum number of units of R such that no deadlock will ever occur is
 (a) 3 (b) 4 (c) 5 (d) 4

Automata Theory

Instructions

A. The following abbreviations are used in this chapter.

FSM	-	Finite State Machine
DFSM	-	Deterministic Finite State Machine
NDFSM	-	Non-Deterministic Finite State Machine
PDM	-	Push Down Machine
DPDM	-	Deterministic Push Down Machine
NDPDM	-	Non-Deterministic Push Down Machine
TM	-	Turing Machine
UTM	-	Universal Turing Machine
CFG	-	Context Free Grammar
CF	-	Context Free
CFL	-	Context Free Language
CSG	-	Context Sensitive Grammar

B. In Transition diagrams, states are represented by circles.

The start state is represented by a circle pointed to by an arrow.

A final state is represented by a circle encircled by another.

C. In a CFG, unless stated otherwise, grammar symbol on the left hand side of the first production, is the start symbol.

1. The word 'formal' in formal languages means

- (a) the symbols used have well-defined meaning
- (b) they are unnecessary, in reality
- (c) only the form of the string of symbols is significant
- (d) none of the above

16. Critical region is
 - (a) a part of the operating system which is not allowed to be accessed by any process
 - (b) a set of instructions that access common shared resource which exclude one another in time
 - (c) the portion of the main memory which can be accessed only by one process at a time
 - (d) none of the above
17. Kernel is
 - (a) considered as the critical part of the operating system
 - (b) the software which monitors the operating system
 - (c) the set of primitive functions upon which the rest of operating system functions are built up.
 - (d) none of the above
18. With a single resource, deadlock occurs
 - (a) if there are more than two processes competing for that resource
 - (b) if there are only two processes competing for that resource
 - (c) if there is a single process competing for that resource
 - (d) none of the above
19. Necessary conditions for deadlock are
 - (a) non-preemption and circular wait
 - (b) Mutual exclusion and partial allocation
 - (c) both (a) and (b)
 - (d) none of the above
20. In a time-sharing operating system, when the time slot given to a process is completed, the process goes from the RUNNING state to the
 - (a) BLOCKED state
 - (b) READY state
 - (c) SUSPENDED state
 - (d) TERMINATED state
21. At a particular time, the value of a counting semaphore is 10. It will become 7 after
 - (a) 3 V operations
 - (b) 3 P operations
 - (c) 5 V operations and 2 P operations
 - (d) 13 P operations and 10 V operations
22. Supervisor call
 - (a) is a call made by the supervisor of the system
 - (b) is a call with control functions
 - (c) are privileged calls that are used to perform resource management functions, which are controlled by the operating system.
 - (d) is a call made by someone working in root directory
23. Semaphores are used to solve the problem of
 - (a) race condition
 - (b) process synchronization
 - (c) mutual exclusion
 - (d) none of the above
24. If the property of locality of reference is well pronounced in a program
 - (a) the number of page faults will be more
 - (b) the number of page faults will be less

Let the mutex be initialized to 1. Any one of the 9 processes P_i , $i = 1, 2, 3, \dots, 9$ can get into the critical section after executing $P(\text{mutex})$ which decrements the mutex value to 0. At this time P_{10} can enter into the critical section as it uses $V(\text{mutex})$ instead of $P(\text{mutex})$ to get into the critical section. As a result of this, mutex will be incremented by 1. Now any one of the 9 processes P_i , $i = 1, 2, 3, \dots, 9$ (excepting the one that is already inside the critical section) can get into the critical section after decrementing the mutex to 0. None of the remaining processes can get into the critical section.

If the mutex is initialized to 0, only 2 processes can get into the critical section. So the largest number of processes is 3.

- (c) the number of page faults will remain the same
 (d) execution will be faster
- *25. At a particular time of computation, the value of a counting semaphore is 7. Then 20 P operations and ' x ' V operations were completed on this semaphore. If the final value of the semaphore is 5, x will be
 (a) 15 (b) 22 (c) 18 (d) 13
26. Pre-emptive scheduling, is the strategy of temporarily suspending a running process
 (a) before the CPU time slice expires (b) to allow starving processes to run
 (c) when it requests I/O (d) none of the above
27. Mutual exclusion problem occurs
 (a) between two disjoint processes that do not interact
 (b) among processes that share resources
 (c) among processes that do not use the same resource
 (d) none of the above
28. Sector interleaving in disks is done by
 (a) the disk manufacturer (b) the disk controller cord
 (c) the operating system (d) none of the above
- *29. Memory protection is of no use in a
 (a) single user system (b) non-multiprogramming system
 (c) non-multitasking system (d) none of the above
30. Some computer systems support dual mode operation—the user mode and the supervisor or monitor mode. These refer to the modes
 (a) by which user programs handle their data
 (b) by which the operating system executes user programs
 (c) in which the processor and the associated hardware operate.
 (d) of memory access
31. Disk scheduling involves deciding
 (a) which disk should be accessed next
 (b) the order in which disk access requests must be serviced
 (c) the physical location where files should be accessed in the disk
 (d) none of the above
- *32. A computer system has 6 tape drives, with ' n ' processes competing for them. Each process may need 3 tape drives. The maximum value of ' n ' for which the system is guaranteed to be deadlock free is
 (a) 2 (b) 3 (c) 4 (d) 1
33. Dirty bit is used to show the
 (a) page with corrupted data
 (b) wrong page in the memory
 (c) page that is modified after being loaded into cache memory
 (d) page that is less frequently accessed

34. Fence register is used for
 (a) CPU protection (b) memory protection
 (c) file protection (d) all of the above
35. Which of the following is a service not supported by the operating system?
 (a) Protection (b) Accounting (c) Compilation (d) I/O operation
36. The first-fit, best-fit and the worst-fit algorithm can be used for
 (a) contiguous allocation of memory (b) linked allocation of memory
 (c) indexed allocation of memory (d) all of the above
37. Which of the following are single-user operating systems?
 (a) MS-DOS (b) UNIX (c) XENIX (d) OS/2
38. In Round Robin CPU scheduling, as the time quantum is increased, the average turn around time
 (a) increases (b) decreases (c) remains constant (d) varies irregularly
39. In a multiprogramming environment
 (a) the processor executes more than one process at a time
 (b) the programs are developed by more than one person
 (c) more than one process resides in the memory
 (d) a single user can execute many programs at the same time.
40. Which of the following are true?
 (a) A re-entrant procedure can be called any number of times.
 (b) A re-entrant procedure can be called even before the procedure has not returned from its previous call.
 (c) Re-entrant procedures cannot be called recursively.
 (d) Re-entrant procedures can be called recursively.
41. In a paged memory, the page hit ratio is 0.35. The time required to access a page in secondary memory is equal to 100 ns. The time required to access a page in primary memory is 10 ns. The average time required to access a page is
 (a) 3.0 ns (b) 68.0 ns (c) 68.5 ns (d) 78.5 ns
42. A state is safe if the system can allocate resources to each process (up to its maximum) in some order and still avoid deadlock.
 Which of the following are true?
 (a) Deadlocked state is unsafe.
 (b) Unsafe state may lead to a deadlock situation.
 (c) Unsafe state must lead to a deadlock situation.
 (d) Deadlocked state is a subset of unsafe state.
43. The size of the virtual memory depends on the size of the
 (a) data bus (b) main memory
 (c) address bus (d) none of the above

69. To specify a particular segment, 5 bits are required (since $2^5 = 32$). Having selected a page, to select a particular byte one needs 10 bits (since $2^{10} = 1$ K byte). So, totally $5 + 10 = 15$ bits are needed.
70. The disk drive has to traverse totally 146 cylinders (verify). So, seek time is $6 \times 146 = 876$ ms.
72. To cover 2400×62500 bits, 60 s are needed. Average latency time is the time needed to traverse 100 tracks i.e., 100×62500 bits, which is 2.5 s.
78. As this scheduling policy has a better average response time for the interactive users.
79. When it tries to access 0100, it results in a page fault as the memory is empty right now. So, it loads the second page (which has the addresses 100-199). Trying to access 200 will result in a page fault, as it is not in memory right now. So the third page with the addresses from 200 to 299 will replace the second page in memory. Trying to access 430 will result in another page fault. Proceeding this way, we find trying to access the addresses 0510, 0120, 0220, and 0320 will all result in page faults. So, altogether 7 page faults.
80. There are 64 words in a block. So the 4 K cache has $(4 \times 1024)/64 = 64$ blocks. Since 1 set has 4 blocks, there are 16 sets. 16 sets needs 4 bits for representation. In a set there are 4 blocks, which needs 2 bits. Each block has 64 words. So, the word field has 6 bits.
81. The memory configuration after the arrival of the jobs 1, 2 and 3 and the termination of job 1 can be depicted as:

FREE-200	JOB2-350	JOB3-300	FREE-150
----------	----------	----------	----------

First fit algorithm will allocate the FREE-200 slot for job 4. But best fit algorithm will allocate the FREE-150 slot for job 4. The memory configuration for the first fit and best fit will be

JOB4-120	FREE-80	JOB2-350	JOB3-300	FREE-150
----------	---------	----------	----------	----------

and

FREE-200	JOB2-350	JOB3-300	JOB4-120	FREE-30
----------	----------	----------	----------	---------

respectively. When job 5 arrives, it will be allotted the FREE-150 slot by the first fit algorithm and the FREE-200 slot by the best fit algorithm. The memory allocation table for the first fit and best fit will be

JOB4-120	FREE-80	JOB2-350	JOB3-300	JOB5-150
----------	---------	----------	----------	----------

and

JOB5-150	FREE-50	JOB2-350	JOB3-300	FREE-30
----------	---------	----------	----------	---------

When Job 6 arrives, it will be allotted the FREE-80 slot by the first fit algorithm. The best-fit algorithm will find no room to store Job 5 as the needed 80 K, is not available contiguously. So, it has to wait till a job terminates. So, the first-fit algorithm performs better in this case.

89. Locality of reference is based on the fact that a page that is referenced is likely to be referenced again in the near future.

Explanations

15. Deadlock occurs when each of the 3 user processes hold one resource and make simultaneous demand for another. If there are 4 resources one of the 3 user processes will get the fourth instance of the resource and relinquish one or both of the resource(s) it is currently holding after using.
25. Each P operation will decrease the semaphore value by 1 and V operation increases it by 1. If x is 18, then 7 P operations will make semaphore value 0. If this is followed by 7 V operations the value comes back to 7. So, after 18 P and 18 V operations, the value of the semaphore will be 7. The remaining 2 P operations result in the semaphore value 5.
29. Even in a non-multiprogramming system, memory protection may be used, when, for example, spooling is being used.
32. 2 process can never lead to deadlock as the peak time demand of 6 (3 + 3) tape drives can be satisfied. But 3 processes can lead to a deadlock if each hold 2 drives and then demand one more.
41. $0.35 \times 10 + (1 - 0.35) \times 100 = 68.5$ ns
44. The arrival pattern is a Poisson distribution.
 $P(k \text{ requests}) = e^{-\mu T} (\mu T)^k / k!$
 Here $k = 0$, $\mu = 20$, $T = 3/4$.
 So required probability is e^{-15}
52. It is $0 + 10 + (15 - 2) + (18 - 5) + (38 - 10)$ divided by 5, i.e., 12.8 ms.
53. It is $8 + 0 + 3 + 15 + 8$ divided by 5, i.e., 6.8 ms.
54. It is $10 + 3 + 0 + 15 + 0$ divided by 5, i.e., 5.6 ms.
55. It is $30 + 0 + 3 + 3 + 18$ divided by 5, i.e., 10.8 ms.
56. It is $30 + 3 + 0 + 5 + 0$ divided by 5, i.e., 7.6 ms.
60. Having 11 resources ensures that at least 1 process will have no pending request. This process after using will release the resources and so deadlock can never occur.
61. At least one process will be holding 2 resources in case of a simultaneous demand from all the processes. That process will release the 2 resources, thereby avoiding any possible deadlock.
62. Using Banker's algorithm, one can show that one process has to acquire all its needed resources. This process, after completing its task, will release all its resources, thereby avoiding any possible deadlock.
63. The first 3 references A, B, C fills the internal storage with A, B, C in 3 page transfers. Now the next reference D results in a page fault. So, page A is downloaded and D takes its place after a page transfer. So, the internal store has D, B and C. The next reference is A—results in a page fault. So, a page transfer takes place and swaps B and A. Continuing this way, we find totally 9 page transfers are necessary.
67. Refer Qn 63. Applying the same logic, we find the required number of page transfer is 10. So, increasing the number of pages need not necessarily reduce the number of page faults. It is the actual sequences of references that decides.

- *44. In a multi-user operating system, 20 requests are made to use a particular resource per hour, on an average. The probability that no requests are made in 45 minutes is
 (a) e^{-15} (b) e^{-5} (c) $1 - e^{-5}$ (d) $1 - e^{-10}$
45. In which of the following scheduling policies does context switching never take place?
 (a) Round-robin (b) Shortest job first
 (c) Pre-emptive (d) First-cum-first-served
46. In which of the following directory systems, is it possible to have multiple complete paths for a file, starting from the root directory?
 (a) Single level directory (b) Two level directory
 (c) Tree structured directory (d) Acyclic graph directory
47. Suppose that a process is in 'BLOCKED' state waiting for some I/O service. When the service is completed, it goes to the
 (a) RUNNING state (b) READY state
 (c) SUSPENDED state (d) TERMINATED state
48. In a system that does not support swapping
 (a) the compiler normally binds symbolic addresses (variables) to relocatable addresses.
 (b) the compiler normally binds symbolic addresses to physical addresses.
 (c) the loader binds relocatable addresses to physical addresses.
 (d) binding of symbolic addresses to physical addresses normally takes place during execution.
49. To obtain better memory utilization, dynamic loading is used. With dynamic loading, a routine is not loaded until it is called for. For implementing dynamic loading,
 (a) special support from hardware is essential
 (b) special support from operating system is essential
 (c) special support from both hardware and operating system are essential
 (d) user programs can implement dynamic loading without any special support from the operating system or the hardware.
50. Which of the following is true?
 (a) The linkage editor is used to edit programs which have to be later linked together.
 (b) The linkage editor links object modules during compiling or assembling.
 (c) The linkage editor links object modules and resolves external references between them before loading.
 (d) The linkage editor resolves external references between the object modules during execution time.
51. Which of the following is true?
 (a) Overlays are used to increase the size of physical memory.
 (b) Overlays are used to increase the logical address space.
 (c) When overlays are used, the size of a process is not limited to the size of physical memory.
 (d) Overlays are used whenever the physical address space is smaller than the logical address space.

The next 5 questions are based on the following information.

Consider a set of 5 processes whose arrival time, CPU time needed and the priority are given below:

Process	Priority	Arrival Time (in ms)	CPU Time Needed (in ms)	Priority
P1		0	10	5
P2		0	5	2
P3		2	3	1
P4		5	20	4
P5		10	2	3

Note: Smaller the number, higher the priority.

- *52. If the CPU scheduling policy is FCFS, the average waiting time will be
 (a) 12.8 ms (b) 8 ms (c) 16 ms (d) none of the above
- *53. If the CPU scheduling policy is SJF, the average waiting time (without pre-emption) will be
 (a) 12.8 ms (b) 6.8 ms (c) 17 ms (d) none of the above
- *54. If the CPU scheduling policy is SJF with pre-emption, the average waiting time will be
 (a) 8 ms (b) 14 ms (c) 5.6 ms (d) none of the above
- *55. If the CPU scheduling policy is priority scheduling without pre-emption, the average waiting time will be
 (a) 12.8 ms (b) 11.8 ms (c) 10.8 ms (d) none of the above
- *56. If the CPU scheduling policy is priority scheduling with pre-emption, the average waiting time will be
 (a) 19 ms (b) 7.6 ms (c) 8 ms (d) none of the above
57. In partitioned memory allocation scheme, the
 (a) best fit algorithm is always better than the first fit algorithm.
 (b) first fit algorithm is always better than the best fit algorithm.
 (c) superiority of the first fit and best-fit algorithms depend on the sequence of memory requests.
 (d) none of the above
58. Cascading termination refers to termination of all child processes before the parent terminates
 (a) normally
 (b) abnormally
 (c) normally or abnormally
 (d) none of the above
59. For implementing a multiprogramming operating system
 (a) special support from processor is essential
 (b) special support from processor is not essential
 (c) cache memory must be available
 (d) more than one processor must be available

- *93. Each process P_i , $i = 1, 2, 3, \dots, 9$ is coded as follows.

```
repeat
    P(mutex)
    { critical section }
    V(mutex)
forever
```

The code for P10 is identical except that it uses $V(mutex)$ instead of $P(mutex)$. What is the largest number of processes that can be inside the critical section at any moment?

- (a) 1 (b) 2 (c) 3 (d) none of the above

94. When an interrupt occurs, an operating system

- (a) ignores the interrupt
 (b) always changes the state of the interrupted process after processing the interrupt.
 (c) always resumes execution of the interrupted process after processing the interrupt
 (d) may change the state of the interrupted process to "blocked" and schedule another process.

Answers

- | | | | | |
|----------|-------------|----------|----------|----------|
| 1. c | 2. c | 3. c | 4. c | 5. c |
| 6. c | 7. b | 8. a | 9. a | 10. d |
| 11. d | 12. b, c | 13. a | 14. b | 15. b |
| 16. b | 17. c | 18. d | 19. c | 20. b |
| 21. b, d | 22. c | 23. b, c | 24. b, d | 25. c |
| 26. a | 27. b | 28. c | 29. d | 30. c |
| 31. b | 32. a | 33. c | 34. b | 35. c |
| 36. a | 37. a, c | 38. d | 39. c | 40. b, d |
| 41. c | 42. a, b, d | 43. c | 44. d | 45. b, d |
| 46. d | 47. b | 48. a, c | 49. d | 50. c |
| 51. c | 52. a | 53. b | 54. c | 55. c |
| 56. b | 57. c | 58. c | 59. b | 60. a |
| 61. a | 62. a | 63. c | 64. b | 65. c |
| 66. c | 67. b | 68. d | 69. c | 70. d |
| 71. a | 72. a | 73. a | 74. b | 75. a |
| 76. b | 77. c | 78. b | 79. c | 80. d |
| 81. a | 82. b | 83. b | 84. b | 85. c |
| 86. d | 87. c | 88. c, d | 89. b | 90. c |
| 91. c | 92. a | 93. c | 94. d | |

This system is in a deadlock state. This remark is

- (a) true (b) false
(c) impossible to determine (d) unpredictable

85. Which of the following is a safe sequence?

- (a) P0, P1, P2, P3 (b) P1, P0, P3, P2 (c) P2, P0, P1, P3 (d) None of the above

86. A demand paging system, with page table held in registers, takes 5 ms to service a page fault if an empty page is available, or if the page to be replaced is not dirty. It takes 15 ms if the replaced page is dirty. Memory access time is 1 μ s. Assume we want an effective access time of 2 μ s and that the page to be replaced is dirty 60% of the time. What is the approximate maximum acceptable page fault rate to meet this access time requirement?

- (a) 0.1% (b) 1.0% (c) 2.5% (d) 0.01%

87. Consider a computer with 8 Mbytes of main memory and a 128 K cache. The cache block size is 4 K. It uses a direct mapping scheme for cache management. How many different main memory blocks can map onto a given physical cache block?

- (a) 2048 (b) 256 (c) 64 (d) None of the above

88. Which of the following applications are well suited for batch processing?

- (a) Process control (b) Video game control
(c) Preparing pay bills of employees (d) Preparing mailing addresses

*89. Locality of reference implies that the page reference being made by a process

- (a) will always be to the page used in the previous page reference.
(b) is likely to be one of the pages used in the last few page references.
(c) will always be one of the pages existing in memory.
(d) will always leads to a page fault.

90. The correct matching for the following pairs

- (A) Disk scheduling (1) Round robin
(B) Batch Processing (2) SCAN
(C) Time sharing (3) LIFO
(D) Interrupt processing (4) FIFO

is:

- (a) A-3, B-4, C-2 and D-1 (b) A-4, B-3, C-2 and D-1
(c) A-2, B-4, C-1 and D-3 (d) A-2, B-1, C-4 and D-3

91. Thrashing

- (a) reduces page I/O
(b) decreases the degree of multiprogramming
(c) implies excessive page I/O
(d) improves the system performance

92. Dirty bit for a page in a page table

- (a) helps avoid unnecessary writes on a paging device
(b) helps maintain LRU information
(c) allows only read on a page
(d) none of the above

*60. Consider a system having 'm' resources of the same type. These resources are shared by 3 processes A, B, C, which have peak time demands of 3, 4, 6 respectively. The minimum value of 'm' that ensures that deadlock will never occur is

- (a) 11 (b) 12 (c) 13 (d) 14

*61. A system has 3 processes sharing 4 resources. If each process needs a maximum of 2 units then, deadlock

- (a) can never occur (b) may occur
(c) has to occur (d) none of the above

*62. 'm' processes share 'n' resources of the same type. The maximum need of each process doesn't exceed 'n' and the sum all their maximum needs is always less than $m + n$. In this set up deadlock

- (a) can never occur (b) may occur
(c) has to occur (d) none of the above

*63. A process refers to 5 pages, A, B, C, D and E in the order - A; B; C; D; A; B; E; A; B; C; D; E. If the page replacement algorithm is FIFO, the number of pages which transfer with an empty internal store of 3 frames is

- (a) 8 (b) 10 (c) 9 (d) 7

64. Distributed systems should

- (a) meet prescribed time constraints (b) aim better resource sharing
(c) aim better system utilization (d) aim low system overhead

65. The main function of shared memory is to

- (a) use primary memory efficiently (b) do intra process communication
(c) do inter process communication (d) none of the above

66. Which of the following is the most suitable scheduling scheme in a real-time operating system?

- (a) round-robin (b) first-come-first-served
(c) pre-emptive scheduling (d) random scheduling

*67. In Question number 63, if the number of available page frames is increased to 4 then the number of page transfers

- (a) decreases (b) increases
(c) remains the same (d) none of the above

68. 'Aging' is

- (a) keeping track of cache contents
(b) keeping track of what pages are currently residing in the memory.
(c) keeping track of how many times a given page is referenced.
(d) increasing the priority of jobs to ensure termination in a finite time.

*69. If there are 32 segments, each of size 1 kbytes, then the logical address should have

- (a) 13 bits (b) 14 bits (c) 15 bits (d) 16 bits

70. Disk requests come to a disk driver for cylinders in the order 10, 22, 20, 2, 40, 6 and 38, at a time when the disk drive is reading from cylinder 20. The seek time is 6 ms per cylinder. The total seek time, if the disk arm scheduling algorithm is first-come-first-served is
 (a) 360 ms (b) 850 ms (c) 900 ms (d) none of the above
71. In question 70, if the scheduling algorithm is the closest cylinder next, then the total seek time will be
 (a) 360 ms (b) 876 ms (c) 850 ms (d) 900 ms
72. A certain moving arm disk storage with one head has following specifications:
 Number of tracks / recording surface = 200
 Disk rotation speed = 2400 rpm
 Track storage capacity = 62500 bits
 The average latency time (assume that the head can move from one track to another only by traversing the entire track) is
 (a) 2.5 s (b) 2.9 s (c) 3.1 s (d) 3.6 s
73. Memory protection is normally done by the
 (a) processor and the associated hardware (b) operating system
 (c) compiler (d) user program
74. Which of the following scheduling algorithms gives minimum average waiting time?
 (a) FCFS (b) SJF (c) Round-robin (d) Priority
75. In question number 72, the transfer rate will be
 (a) 2.5 Mbits/s (b) 4.25 Mbits/s (c) 1.5 Mbits/s (d) 3.75 Mbits/s
76. In a paged segmented scheme of memory management, the segment table itself must have a page table because
 (a) the segment table is often too large to fit in one page
 (b) each segment is spread over a number of pages
 (c) segment tables point to page tables and not to the physical location of the segment
 (d) the processor's description base register points to a page table
77. Which of the following page replacement algorithms suffers from Belady's anomaly?
 (a) Optimal replacement (b) LRU
 (c) FIFO (d) Both optimal replacement and FIFO
78. Which of the following scheduling policy is well suited for a time-shared operating system?
 (a) Shortest job first (b) Round robin
 (c) First-come-first-serve (d) Elevator
79. The address sequence generated by tracing a particular program executing in a pure demand paging system with 100 records per page, with 1 free main memory frame is recorded as follows. What is the number of page faults?
 0100, 0200, 0430, 0499, 0510, 0530, 0560, 0120, 0220, 0240, 0260, 0320, 0370.
 (a) 13 (b) 8 (c) 7 (d) 10

- *80. A computer system has 4 K word cache organized in a block-set-associative manner, with 4 blocks per set, 64 words per block. The number of bits in the SET and WORD fields of the main memory address format is
 (a) 15, 4 (b) 6, 4 (c) 7, 2 (d) 4, 6
- *81. A computer installation has 1000 K of main memory. The jobs arrive and finish in the following sequence.
 Job 1 requiring 200 K arrives
 Job 2 requiring 350 K arrives
 Job 3 requiring 300 K arrives
 Job 1 finishes
 Job 4 requiring 120 K arrives
 Job 5 requiring 150 K arrives
 Job 6 requiring 80 K arrives
 Among best fit and first fit, which performs better for this sequence?
 (a) First fit (b) Best fit
 (c) Both perform the same (d) None of the above
82. A memory page containing a heavily used variable that was initialized very early and is in constant use is removed, when the page replacement algorithm used is
 (a) LRU (b) FIFO (c) LFU (d) none of the above
83. Consider the following heap.

JOB1-50	Free-150	JOB2-300	FREE-350	JOB3-600
---------	----------	----------	----------	----------

 The sequence of requests for blocks of sizes 300, 25, 125, 50 can be satisfied if we use
 (a) either first fit or best fit policy (b) first fit but not best fit
 (c) best fit but not first fit (d) none of the above
84. Consider the resource allocation graph in Fig. 5.1.

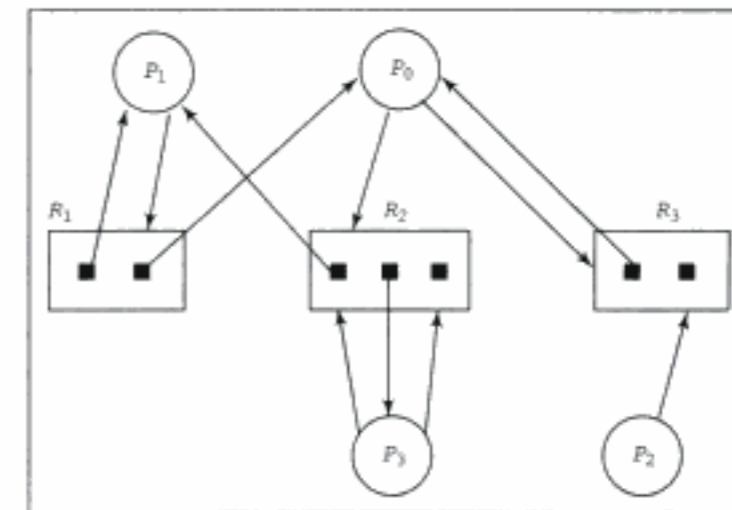

Fig. 5.1